

SECTION 5: GENERAL INFORMATION

NOTE: Plans pages may refer to Section 5 by a letter designation. Please refer to the conversion chart below to find the corresponding section's numerical designation.

#	LETTER		#	LETTER		#	LETTER	
5.1	5A	ALUMINUM PRIMING & PAINTING	5.11	5L	FORMING ALUMINUM PARTS FROM SHEET	5.21	5W	ELECTRICAL
5.2	5B	EDGE FINISHING, DEBURRING & SCRATCH REMOVAL	5.12	5M	VINYL COATING	5.22	5X	COMPRESSION FITTINGS
5.3	5C	MARKING PARTS	5.13	5N	FLUTING	5.23	5Y	NYLON FLUID FITTINGS
5.4	5D	RIVETING	5.14	5P	ALUMINUM TUBING	5.24	5Z	DRILLING, TAPS & DIES
5.5	5E	COUNTERSINKING & DIMPLING	5.15	5Q	STEEL	5.25	---	DIMENSIONS
5.6	5F	BACK RIVETING	5.16	5R	INSTALLING NUTPLATES	5.26	---	HARDWARE REFERENCE
5.7	5G	FOLDED TRAILING EDGES	5.17	5S	FUEL TANK SEALANT	5.27	---	FLUID FITTINGS
5.8	5H	RIVETED TRAILING EDGES	5.18	5T	FIBERGLASS	5.28	---	CONCLUSION
5.9	5J	ROLLED LEADING EDGES	5.19	5U	ACRYLIC CANOPY & LEXAN WINDOWS			
5.10	5K	LAP JOINTS	5.20	5V	NUT & BOLT TORQUES			

NOTE: This section is not intended to be a complete manual on aircraft construction. Supplement this information with some of the publications listed in Section 1.

5.1 ALUMINUM PRIMING & PAINTING

The aluminum skins used on RV aircraft are all 2024-T3 alloy. They are "alclad", meaning that both sides of the sheet are coated at the mill with pure aluminum. This forms aluminum oxide, a corrosion resistant material which need not be primed or painted for adequate service as an airframe material. However, if the airplane is to be kept in a salt-air environment, or if a greater margin of corrosion protection is desired, priming the entire inside of the airframe is a good idea. Remember that priming will add cost, weight and time to your project.

WARNING: When installing threaded fittings/rod ends into primed tube be sure that the primer has cured fully. Failure to do so could result in seized bearings.

All non-alclad aluminum parts such as 6061-T6 must be primed. Control System Pushrods must be primed both inside and out. (Do not prime inside of fuel or brake lines.)

To prime the inside of pushrods with liquid primer, pour primer into one end and swirl it towards the other end, coating the entire inside surface. Alternatively, spray primer into one end of the pushrod, turn the pushrod around and spray again from the other end.

The majority of the parts in the kit have been coated in our plant with vinyl to protect them during manufacturing. We suggest that you remove the vinyl as soon as practical after inventorying your kit. (See 5.12) The pre-assembled spars are anodized and need no additional protection.

All aluminum bar, angle, and tube used is not alclad and must be primed to assure corrosion resistance. The traditional primer used on aircraft aluminum has been Zinc Chromate. With proper surface cleaning, this is still a good primer. However, there are many newer primers available which are superior. Most of these are two-part, catalytic curing primers.

Brand	Product
DITZLER - DUPONT-	DP-40/50 EPOXY PRIMER VERI-PRIME (PRIMER #615 and CONVERTER #616S)
MARHYDE - PRATT & LAMBERT - TEMPO - SHERWIN WILLIAMS -	Self-etching primer, available in a spray can as well as quarts Vinyl Zinc Chromate, EX-ER-7 and T-ER-4 Reducer Chromate in a spray can WASH PRIMER #P60G2 and Catalyst Reducer #R7K44

CAUTION: When spray painting ANY primer, work in a well ventilated area and wear, at the very least, a UL approved respirator with carbon filters. Systems providing fresh filtered air have become more affordable in the last few years and provide the operator a superior level of comfort and safety. As the name "Metal Etching Primer" implies, the catalyst component contains an acid which can be dangerous if breathed. Similar precautions must be taken for spraying any of the two-part primers and paints. Check with the paint supplier for exact precautions required.

Primers like P60G2, Vari-Prime and others are relatively inexpensive, light and easy to apply. These characteristics make them appeal to many builders. They do need to be sprayed with a gun, which is awkward for some, but the pain can be minimized if you prepare large batches of parts to reduce set up and clean up time.

Some aerosol primers are useful for small parts when you don't want to set up to spray a whole batch. Usually there will not be a problem with mixing and matching the type of primers used, but we do not know for sure. They are impractical for painting the whole airplane or large skins.

Though some disagree it is generally accepted that two-part epoxy primers provide the best corrosion resistance. However, they are expensive, toxic, heavy and dry slowly making them problematic for the home builder. If one can tolerate these issues and desires an RV that would be in good shape for grandchildren to inherit then two-part epoxy primers may be the "best" solution.

Van's Aircraft does not have an "approved" primer. We use Sherwin Williams P60G2. This is used on the Quick-Builds (QBs) and prototypes made here. The QB's primer has no pigment so it just makes the interior surfaces slightly darker and less shiny. In the US, this primer has a green tint so the two will not match exactly. We use this primer because it is inexpensive, dries fast, and is easy to apply. Sherwin Williams will tell you that the primer needs a top coat. While this is true for optimum corrosion resistance we feel that this is not necessary for the way in which most owners will maintain their RVs.

Whatever you use, prepare the surface as per the manufacturer's instructions. This can be as simple as washing with water or as complex as acid etching and alodining. We have nothing to add to whatever they may advise.



5.1 ALUMINUM PRIMING & PAINTING (continued)

Historically not many manufacturers primed the interior of their products, but there are still many flying 50 year old airplanes without corrosion problems. One favorite analogy around here is the car paint parable. Two cars leave the factory as identically primed and painted as is humanly possible. Five years later one looks as good as the day it left the showroom while the other looks fit for the wrecking yard. Same primer/paint, different result. How you treat it has a much greater effect than the primer you choose. How do you intend to treat your airplane?

An entire book could be written on the subject of aircraft painting and still leave many questions unanswered. There are many surface preparations, primers, and paints available, and more on the market every day. Paints range anywhere from the older enamels and acrylic lacquers up through the newer acrylic enamels, urethanes, and epoxy finishes. Which one is best probably depends on the end result desired by the individual builder. However, the urethanes seem to be favored by most builders now because of their relative ease of application and shiny, maintenance free finish. The purpose of this section is only to present some general ideas, not to provide the "best way" of applying the "best" paint.

COLOR SCHEME

Before getting serious about the type of paint to be used and the method and technique of application, most builders spend many months (or years?) while building trying to decide their paint scheme. Toward this end, little can be offered other than the suggestion that conservative colors and paint scheme will always look good on the basically good lines of an RV. More daring combinations of colors and patterns may result in a "fabulous" paint scheme, or could result in an eyesore too busy or gaudy to be appealing. Unless you have a very good eye for colors and patterns it may not be worth the gamble. We have provided a three-view drawing on which to practice. Just run off a few dozen copies on your office copier (when the boss isn't looking), buy a box of colored pencils and start sketching out your dream scheme. Aside from the aesthetic aspects of color scheme selection, you might also give serious thought to recognition; i.e.; how well will your combination of colors stand out from the background when in flight. How visible will it be to pilots of other aircraft in flight? With the dense air traffic and haze of air pollution encountered around many airports, see-and-be-seen should be a major safety concern to all pilots. Light colors are generally considered to be the most visible against typical backgrounds found while flying in the USA. Yellow is probably the most universally visible, and can also be trimmed to provide very attractive paint schemes.

The question of whether a painted or bare aluminum airplane goes faster is often raised. Experience with the prototype RVs has not provided a definitive answer. It would appear that there is little difference in skin friction drag from a typical painted surface to a typical bare aluminum surface.

PAINTING HEALTH HAZARDS

WARNING: PLEASE TAKE PAINT MANUFACTURER'S TOXIC WARNINGS SERIOUSLY!!!

Spray painting can present a health hazard, particularly with most of the newer two-part paints. Chemicals used in the hardeners of urethane, acrylic enamel, and epoxy paints cause them to be potentially very hazardous if breathed, and can be harmful even through excessive exposure to the skin. For this reason, the painting area must be well ventilated and a UL approved respirator must be used. A simple particle filter is just not good enough. Keep in mind that many paint systems now contain chemicals for which a conventional filter-type respirator is not considered sufficient protection. Only a forced fresh air respirator system is recommended. Also, full coverage clothing should be used to prevent skin exposure. Builders sometimes disregard warnings on the likes of paint cans because they become indifferent after daily exposure to warnings on all sorts of relatively benign household items. But where modern paints products are concerned, warnings should be taken very seriously.

PAINTING

Painting an airplane obviously adds to its weight. The amount of weight depends on the type and amount of paint, primer and surface filler used. A "keep weight to a minimum" paint job will weigh about 15 lbs. A really elaborate paint job with all the extras could add two or three times this weight. In addition, heavy paint jobs will tend to shift the Center of Gravity rearward because of the paint weight on the empennage. Control surface balance on the RVs has not been found to be critical. A normal (light) paint application on the ailerons and elevator will not upset their balance to a noticeable degree. However, a heavy paint job will require that these surfaces be re-balanced and additional counterbalance weight added if necessary.

MASKING

Application of masking tape for color separation and pin-striping is perhaps the most time-consuming part of painting. Masking a straight line is tough enough, but getting just the right curve or "sweep" to a line is an art. Common hardware store masking tape usually gives poor results for distinct line separation because it permits too much "bleed under". Plastic "decorator" tape yields a nice crisp edge, but is rather expensive. Plastic electricians tape works fairly well and is relatively cheap. "Scotch" tape also works well but is hard to remove after painting.

There is no doubt that a smooth, wave free surface offers less aerodynamic drag than an imperfect one, but it is not known how much effect this will have on the speed of an RV. Probably not much unless the entire airframe is filled and smoothed before painting, and then the paint is rubbed-out perfectly smooth. This would entail much work, add weight, and probably not be advisable unless the builder wanted a 100% perfect airplane rather than a 98% perfect one. The price for that last 2% would be high in terms of added work required.

For the typical paint job, the builder obviously should try to work in a dust free environment so the paint surface will be as smooth as possible without the need for rub-out. Spanwise trim stripes should be avoided very near the wing leading edge. Much is being written about the effects of spanwise surface irregularities on the boundary layer control on airfoils, particularly those on canard configuration airplanes. The concern is that any surface irregularity near the wing leading edge, particularly spanwise ones, can disrupt the boundary layer airflow, upset laminar flow, and cause an increase in drag and a decrease in lift. On canard airplanes this can seriously affect not only performance, but also stability and control. On an RV, with its conventional configuration and non-laminar flow airfoil, the effects of surface irregularities are relatively minor. However, a rough paint trim line within the first few inches of the wing leading edge would probably cause a measurable effect on stall and top speeds. Trim lines more than 8-9 inches from the leading edge have a minimal effect, but even then should be rubbed out as smoothly as possible.

5.2 EDGE FINISHING, HOLE DEBURRING & SCRATCH REMOVAL

Aluminum sheet of the 2024-T3 variety is relatively hard and brittle. Maintaining the high strength of this material in use requires that care be taken in its cutting, bending, and finishing. Because it is a hard material, it is scratch and notch sensitive. This means that sharp or rough edges, corners, and scratches can cause stress concentrations which will greatly increase the possibility of local failure, usually in the form of a small crack. The problem with small cracks is that they soon become large cracks, one piece of aluminum becomes two pieces, etc. Obviously, we do not want this happening in our airframe, particularly when separated from solid earth by a lot of very thin air.

SHEARED ALUMINUM SHEET

FINISHED EDGES

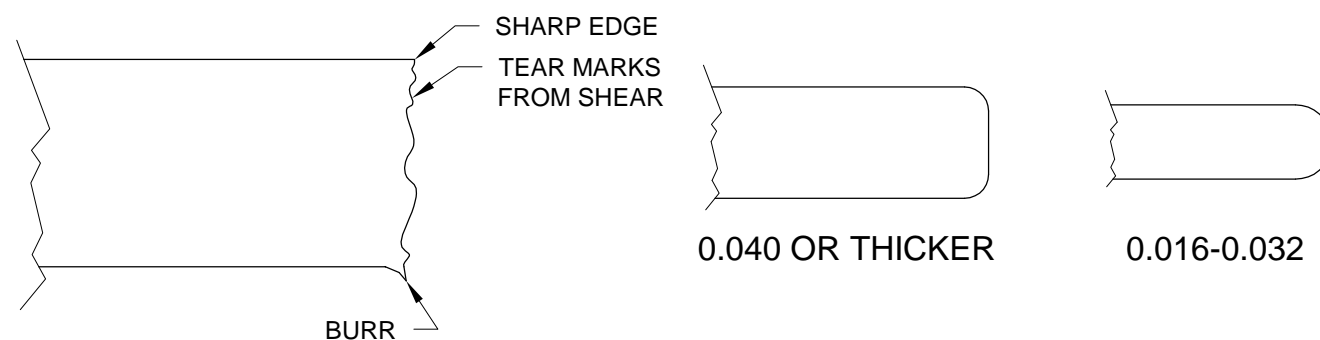
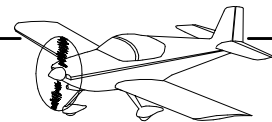


FIGURE 1: EDGES



5.2 (continued)

All aluminum edges and corners must be smoothed and radiused to prevent this stress concentration from occurring. Any sheared edge, whether sheared by hand or by machine, has sharp corners and has a burr on one edge as shown on Page 05-02 Figure 1. This burr must be removed and the sharp edges rounded off. This can be done a number of ways; with a file, a Scotchbrite polishing wheel, sandpaper, or an edge (de-burring) tool. In most instances, the tool, followed by a pass or two over a Scotchbrite wheel mounted in a bench grinder, is the best and quickest method. A good test for the edge finish of aluminum sheet is to run your finger over it. If you can't feel any roughness and there is no chance of drawing blood, the finish is OK. You should not be able to see the original cutting marks on the material. In other words, if the sheet had been sawed (bandsaw or hacksaw), the saw marks should be removed in the process of smoothing.

Corners, particularly inside ones, must be cut with a radius to prevent cracking. See Figure 1. This radius can vary from 1/16" for .016 thick aluminum to 1/8" for .040 aluminum. The radius edge then must be smoothed just as the straight edges discussed above. A small round file works well for this. This is especially important where a bend line is intersecting the inside corner in question. Cracks are likely to occur at the sheet edge even if the bend radius is great enough.

All drilled holes, or prepunched holes that have been final-drilled to a larger size, should also be deburred. Holes that were factory punched to final size can be inspected and only deburred if needed (with the exception of large holes to be dimpled for screws - see below). This is an easy but time-consuming chore, and can be done with an oversize drill bit, either held between your fingers and twisted, or in a variable speed drill running very slowly. Special swivel deburring tools are also available from tool supply houses. These work better and are much quicker. Burrs around holes are a problem mainly in riveting and dimple countersinking. The burr can prevent a rivet head from seating properly and can make dimple countersunk holes more prone to developing cracks radiating from the hole. Many novice builders deburr excessively deep. Deburring should not produce a significant chamfer/counter-sink on the edge of the hole. Be particularly careful deburring holes in .020 or thinner sheet. By the time both sides have been deburred the hole could be enlarged.

The finishing procedures just described will constitute a sizable portion of the total building time. However, they are important for structural reasons as well as cosmetic. Most of these holes, edges, etc. will be inside the airframe and out of sight when the airplane is finished. This is no reason to consider them unimportant. The need for good edge finishing is most difficult to impress on new builders unaccustomed to aircraft standards.

Scratches in the surface of aluminum can have the same weakening effects as rough edges, corners and holes. The alclad sheet used is very easily scratched because of the thin surface layer of soft aluminum. Scratches within this layer will have little effect on strength, but deeper scratches will. The greatest difficulty is deciding how deep a scratch can be before it is a potential problem. The best approach is taking extra care to prevent scratches in the first place. When a scratch does occur sand or buff it out no matter how small. Very light scratches can be removed with #600 wet sandpaper. Deeper ones will require #400 (or perhaps more coarse) sandpaper, followed by #600 for finishing. One thing to remember when removing scratches is that in doing so the corrosion resistant alclad surface of the aluminum is also removed. Therefore any area that has been sanded for scratch removal must be primed.

RIB FLANGE FACETING

As a skin wraps around the leading edge of the horizontal stabilizer, vertical stabilizer, or wing, among others, the skin must pass over the forward edge of the rib flange. See Figure 2. Shape the front edge of the flange to prevent this edge from forming a dent in the skin as the rib is riveted in place. A similar effect will occur at the notch between rib flanges. During manufacturing, as flanges form over the curved edge of a formblock, the ends or surface of the flanges may remain straight or flat rather than conforming to the curvature of the formblock. This results in faceted, instead of uniformly curved mating surfaces. A skin riveted on top of the rib would appear faceted and a bump would occur in the skin in the area of the notch between the rib flanges. Shape-deburr the edges of the flanges especially in the area of the flange radius as required. See Figure 2.

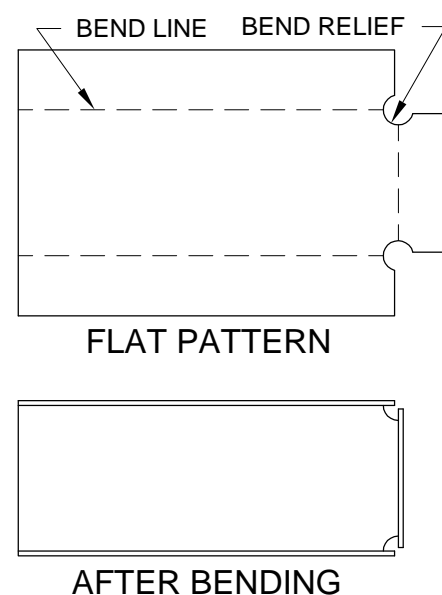


FIGURE 1: BENDING



SHAPE EDGE OF EACH
FLANGE TO REMOVE
"FACETING"

FIGURE 2: RIB FLANGE PREP

FRONT EDGE OF
FORWARD FLANGE

FLANGE RADIUS

5.3 MARKING PARTS

WARNING: NEVER use a scribe to make layout lines or other marks on aircraft parts. Due to engine vibration part failure can occur along these scribe lines. The use of an ordinary lead pencil will cause the aluminum to corrode. We recommend that you only use an extra-fine point "Sharpie" pen. For some unexplained reason the blue ones seem to last longer than other colors. The sharpie ink will bleed through primer so you can still see the ID marks after priming the parts. Be sure to remove any markings in areas that will be visible after completion as the ink will bleed through primer and paint coatings.

5.4 RIVETING

Two types of rivets are used in the construction of an RV; "AN" rivets, and "blind" rivets. Blind rivets are often referred to as Pop Rivets (although "Pop" is actually a brand name). See the blind rivet identifier chart in 5.26. Van's designs utilize blind rivets in specific locations to simplify and speed the construction process and they are set using a pneumatic or hand-operated puller.

Two styles of AN rivets are used; universal head (AN470) and 100° countersunk head (AN426). Three rivet diameters are used; AD3 (3/32), AD4 (1/8), and AD6 (3/16 older kits only). While all the numbers and letters may be confusing at first, they convey useful information, as shown in the sketches at the end of this section. AN rivets are set with either a rivet gun and a bucking bar, or a rivet squeezer. Driving universal head rivets requires a rivet set of a size corresponding to the rivet head size.

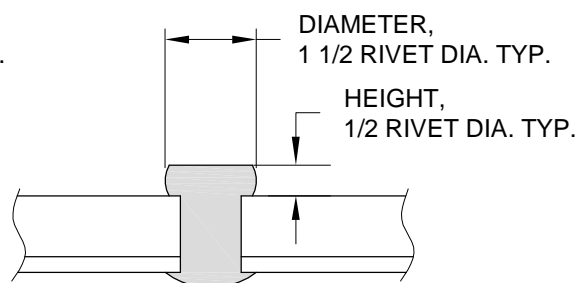
Main wing spar construction uses 3/16 rivets, which require a very high setting pressure, necessitating a heavy-duty rivet gun or a fairly large rivet squeezer. RV kits have pre-assembled spars so builders do not have to set 3/16 rivets.

Rivets must be the correct length. Too long and they tend to bend over like a nail, or "cleat". Too short and there is not enough material to form a full shop head. While the plans usually call out the rivet length required there will still be places where the builder will need to know the correct method of determining rivet length. The rule of thumb is that the length of the rivet shank should equal the thickness of the material being riveted, plus 1.5 times the rivet diameter. For example, if a .016 skin is to be riveted to a .032 rib the material thickness would equal .048. If a #3 rivet (3/32 diameter) is to be used, 1.5 times the rivet diameter would be 9/64. Checking a decimal equivalent chart we find that 9/64=0.140. By adding 0.140 to 0.048, we arrive at a rivet length of 0.188. Rivets come in increments of 1/16, so the nearest rivet would be an AD3-3; 3/16 or 0.1875. This formula works well for rivet lengths up to about 1/2. For thicker material, such as the wing spar, a greater rivet length allowance is required.

In general a properly set rivet will have a shop head diameter of 1.5 times the shank diameter and a height of 1/2 the shank diameter. See Figure 1. A simple gauge is available from tool suppliers. As you gain experience you will find that your eye is very accurate, and the gauge is needed only to "recalibrate" it.

Specification MIL-R-47196A for rivet installation allows for smaller shop heads. The specification is available free online, is informative and worth reading. In many instances, particularly in the newer kits, a shorter rivet will be called out than the one that would meet the guide line above. The shorter rivet will still meet the MIL Spec. requirement. This is done to avoid using a rivet size that may be slightly long and more difficult to properly install.

NOTE: There are times when the correct rivet length is not available. Depending on the application a shorter rivet can be used or a longer rivet cut to the proper length. Using a longer rivet, as is, can result in the shank being bent over like a nail. We have chosen to use a rivet that may seem too short in some places, but will do the job adequately.



RIVET DIA.	DRIVEN HEAD THICKNESS (INCHES)	
	MIN	MAX
3/32	.038	.050
1/8	.050	.070
3/16	.075	.105

FIGURE 1: TYPICAL FORMED RIVET DIMENSIONS

REMOVING BLIND RIVETS

When removing blind rivets with a steel mandrel it is important to drive the mandrel out before attempting to drill out the aluminum body of the rivet. See Figure 2. Otherwise the steel mandrel impedes the drilling process and worse yet can cause the drill bit to "wander" leaving an odd size and shaped hole. Insert a 1/16" pin punch into the hole in the top of the rivet and rap with a hammer to drive the mandrel out. With CherryMax rivets the top of the mandrel (which extends the full height of the rivet) must first be removed with an abrasive wheel in a die grinder or rotary tool to release the small snap ring visible on the top of the installed rivet. With the snap ring removed the mandrel can be driven out and then the rivet drilled out. Best practice is to remove as much rivet debris as possible after any removal operations are complete.

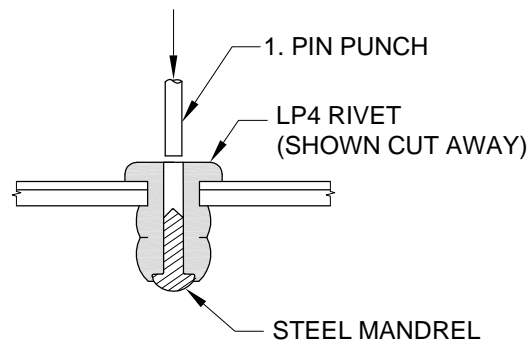


FIGURE 2: DRILLING OUT BLIND RIVETS

REMOVING 'AN' RIVETS

To avoid the possibility of deforming thinner material when removing a rivet, modify a pair of long handled side cutters as shown in Figure 3. This will allow the blades to grip as close to flush with the surface of the material as possible while twisting on the shop head of the rivet to remove it.



FIGURE 3: MODIFY SIDE CUTTERS

Use the method described in Figure 4 for removing rivets from thinner material.

Use the method described in Figure 5 for removing rivets from thicker material.

Note that the method used in Figure 4 can also be used for thicker material when punch and hammer access is limited.

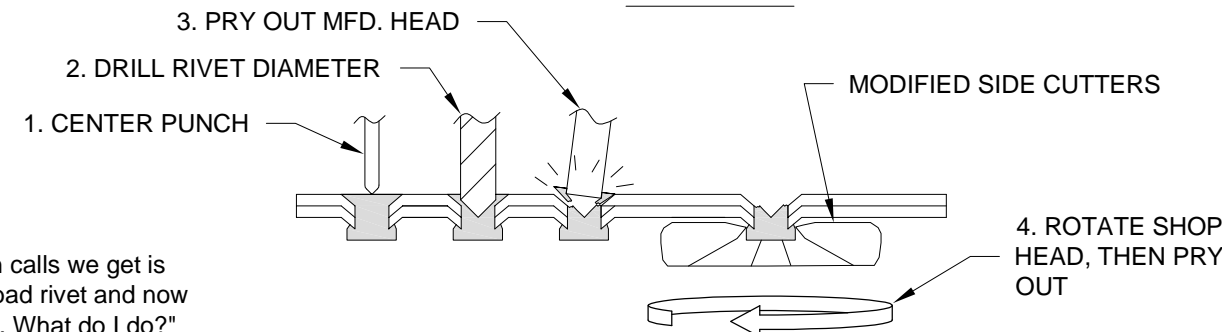


FIGURE 4: REMOVING RIVETS IN THIN MATERIAL

One of the common calls we get is "I had to drill out a bad rivet and now the hole is oversize. What do I do?" Sometimes this is done multiple times in the same hole and now the hole is so large that the builder has to use a bolt and nut instead of a rivet. To relieve the anxiety sometimes associated with an imperfectly set rivet and to avert potential problems arising from ill-advised attempts at repair, (not to say 'never repair a rivet'), guidance in the form of an excerpt from the Alcoa Aluminum Rivet Book, dated 1984, is provided here.

"The standards to which driven rivets should conform are frequently uncertain. In addition to dimensions and perfection of shape, inspection is concerned with whether the drive head is coaxial with the shank (not "clinched") and whether there is excessive cracking of the heads. It has been determined that even badly cracked heads are satisfactory from the standpoint of static strength, fatigue strength and resistance to corrosion. (Poorly set and cracked) rivet heads were tested in tension to determine how well formed a head has to be in order to develop full strength. The tensile strengths of all the rivets were within five percent of the strongest. The test indicated that minor deviations from the theoretically desired shape of head are not cause for concern or replacement. The second rivet that is driven in any one hole [is] likely to be more defective than the first because the hole is enlarged and [the] rivet will be more likely to buckle and form an imperfect head. Tests have shown that very small rivet heads are sufficient to develop the strength of the rivet shank, even when the rivets are subject to a straight tensile pull....where a large head is not needed for appearance, smaller sizes of drive head should be used to decrease the required driving pressures."

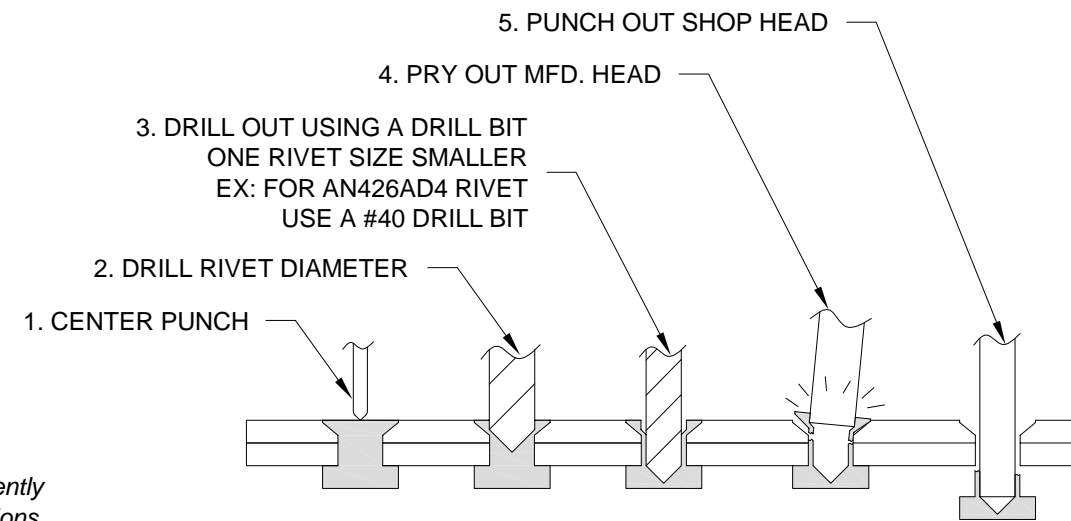
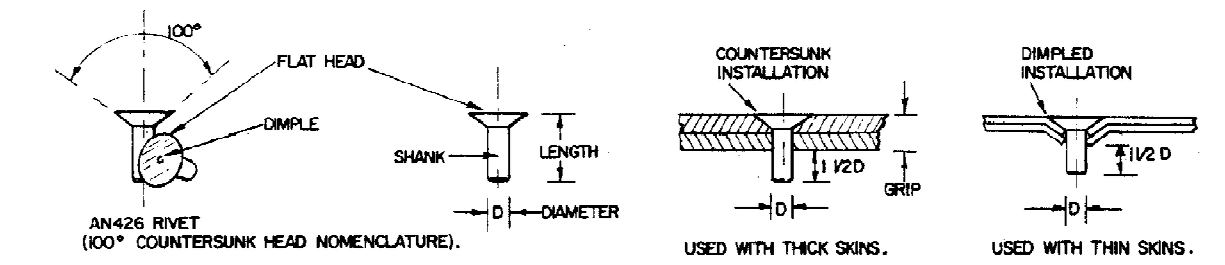
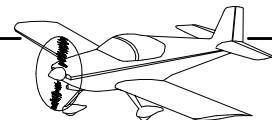


FIGURE 5: REMOVING RIVETS IN THICK MATERIAL



TYPICAL RIVET SPECIFICATION

A N 426 AD 3 4

4/16" LONG (1/4")

3/32" DIAMETER

2117 T4 ALUM. ALLOY

COUNTERSUNK 100° HEAD

NAVY

ARMY

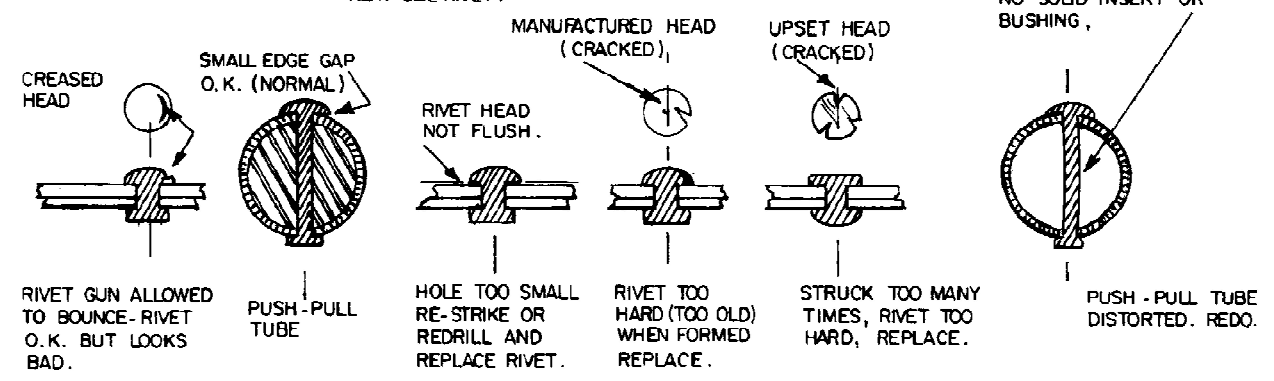
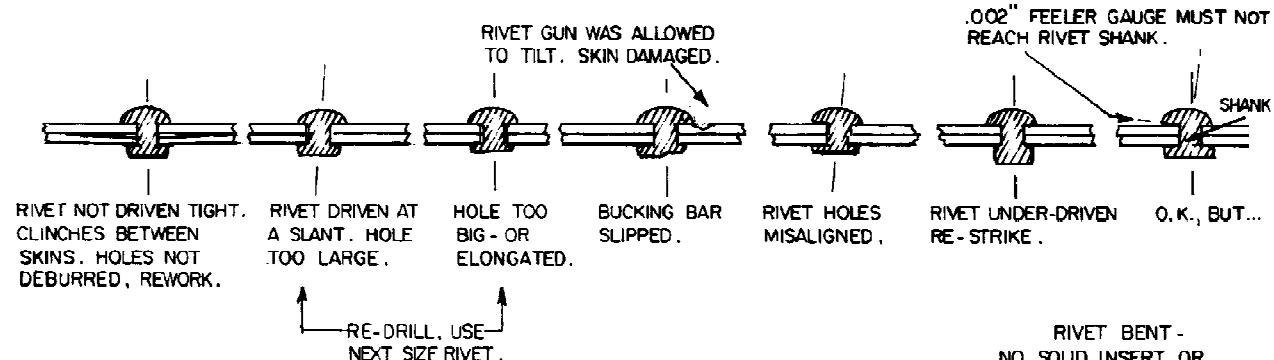
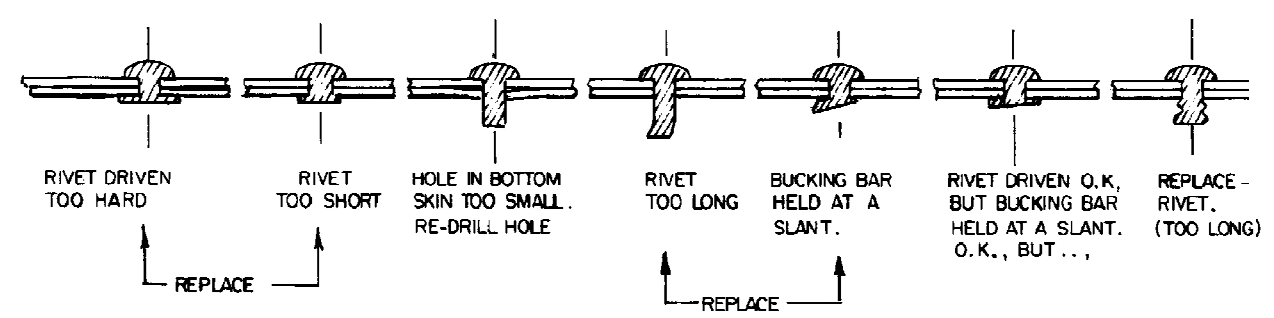
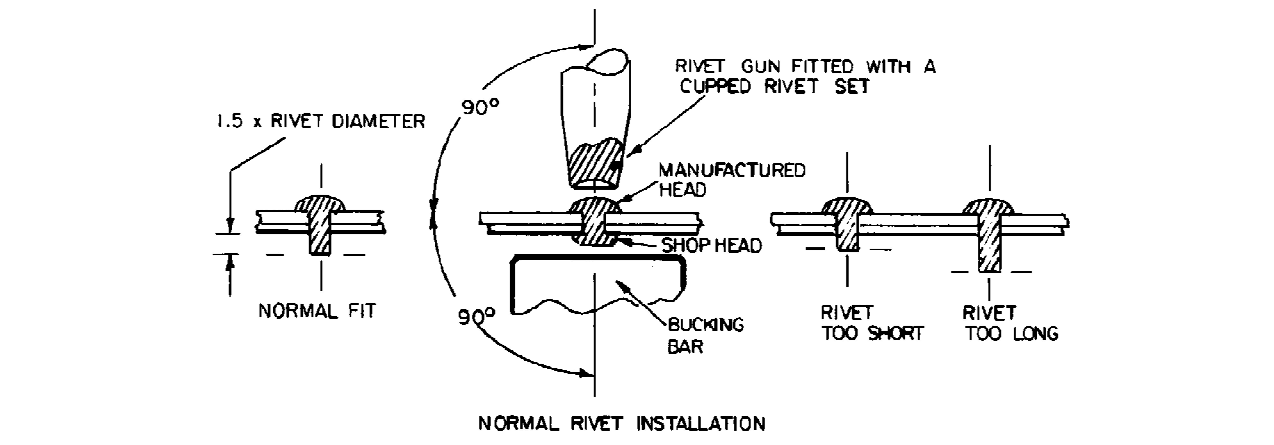
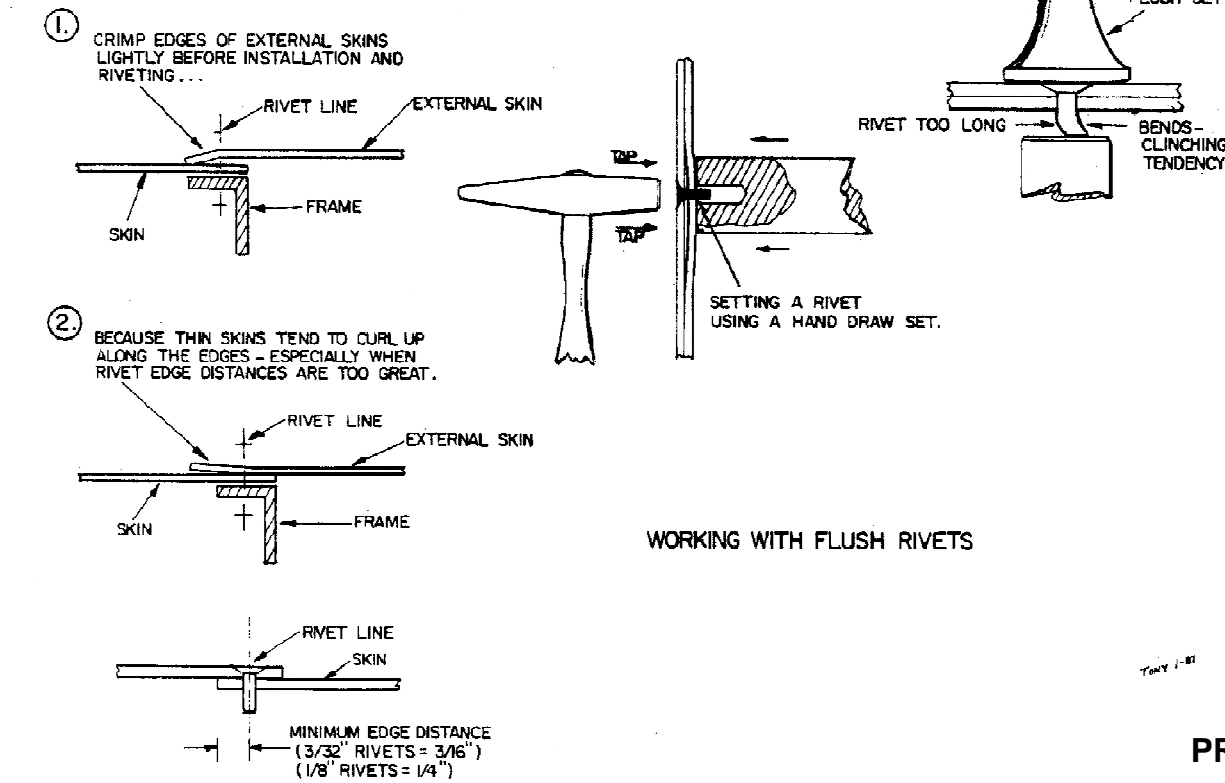
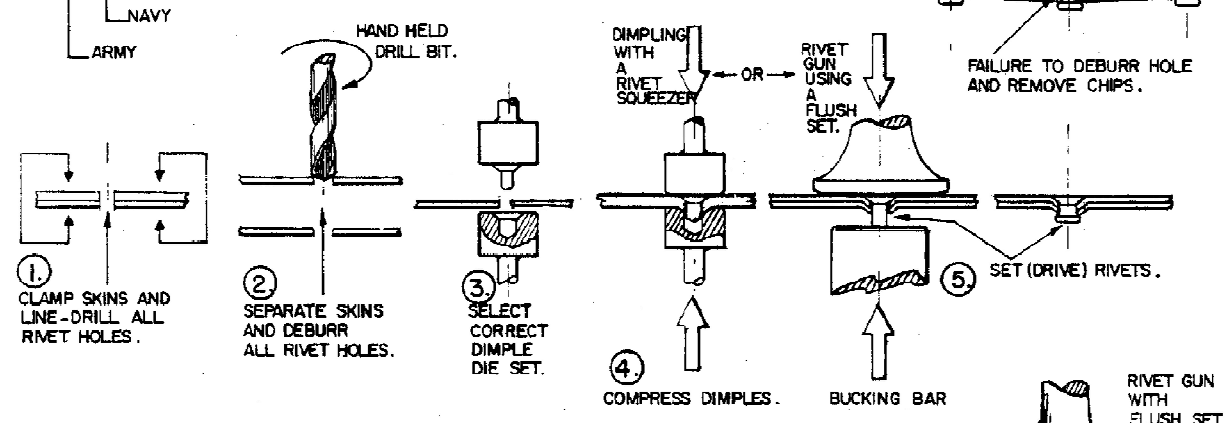
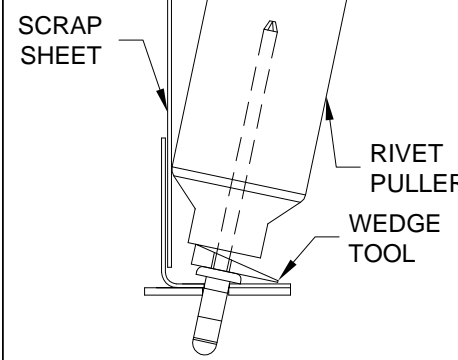
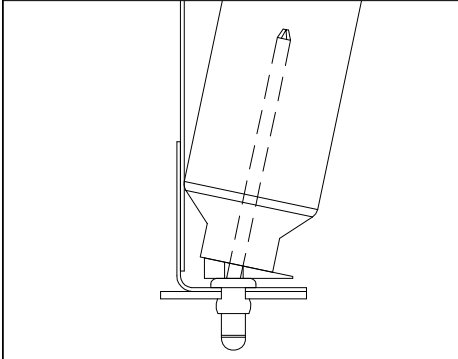
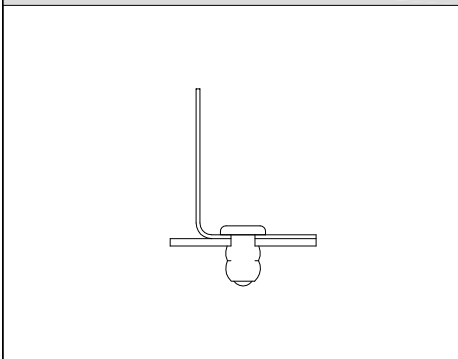


FIGURE 1: RIVETING PROCESS, NOMENCLATURE & COMMONLY ENCOUNTERED PROBLEMS.

Artwork by Tony Bingelis

5.4 (continued)
METHODS FOR SETTING RIVETS

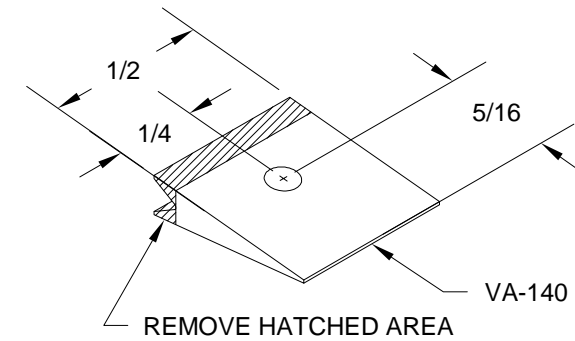
<p>FIGURE 1: SETTING BLIND RIVETS (DOES NOT APPLY TO CHERRY RIVETS, PN: CR-32XX-X-X)</p> <p>BELOW: HOW TO SET A BLIND RIVET IN A DIFFICULT LOCATION.</p> <p>USE PIECE OF VINYL CLAD SCRAP MATERIAL TO PROTECT FINISHED SURFACE.</p> <p>SEE FIGURE 2 FOR INSTRUCTIONS ON FABRICATING THE WEDGE TOOL.</p> <p>STEP 1: ALIGNING RIVET & PARTS</p>		
 <p>SCRAP SHEET</p> <p>RIVET PULLER</p> <p>WEDGE TOOL</p>	<p>CORRECT</p> <p>90°</p> <p>LP4-X SET CORRECTLY</p>	<p>CORRECT</p> <p>90°</p> <p>CS4-X SET CORRECTLY</p> <p>MAX DIM .009</p>
<p>STEP 2: RIVET PROPERLY SEATED</p> 	<p>REPLACE</p> <p>MFG HEAD NOT FLAT ON PART, SET RIVET AT A 90° ANGLE TO PART</p>	<p>REPAIR OR IGNORE DEPENDING ON LOCATION</p> <p>TO REPAIR GRIND EXCESS SHAFT FLUSH WITH MFG HEAD</p>
<p>STEP 3: RIVET PROPERLY SET</p> 	<p>REPLACE</p> <p>MFG HEAD NOT IN CONTACT WITH PART, HOLD MFG HEAD FLAT ON PART WHILE SETTING RIVET</p>	<p>REPLACE</p> <p>RIVET SWELLS BETWEEN PARTS, HOLD PARTS TIGHT AGAINST MFG HEAD</p>

FABRICATING THE WEDGE TOOL

The wedge tool provides assistance when blind riveting in locations where it is not possible to align the tool and the rivet. The wedge tool(s) will be placed between the rivet and the riveting tool enabling the riveting tool to pull the rivet from an angle, yet still achieve a properly seated manufactured head.

Step 1: Cut a length of VA-140 Trailing Edge to the length shown in Figure 2, centered on a .094 hole.

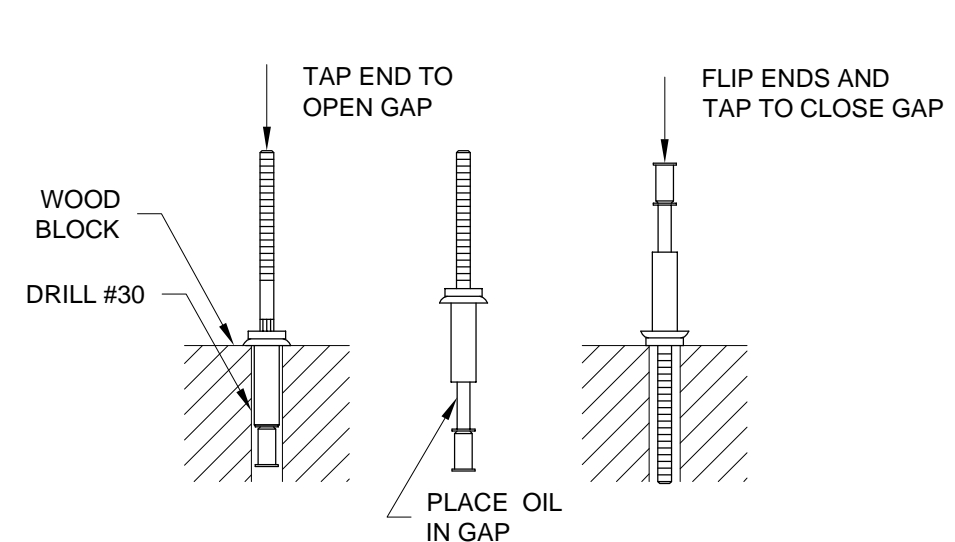
Step 2: Remove the hatched area from the length of VA-140 Trailing Edge as shown in Figure 2.

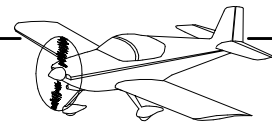

FIGURE 2: WEDGE TOOL FABRICATION
CCR-246SS-3-2

CCR-246SS-3-2 blind rivets that are specified in many locations should not be considered a replacement for 3/32" AN426 rivets that are being used in structural applications. They are acceptable for installation of nutplates or in other low load locations. When installing the CCR blind rivet it is normal for the stem to pull entirely out of the rivet.

CHERRY RIVET LUBRICATION

CherryMAX rivets may experience some loss of factory lubrication resulting in premature mandrel breakage. Restore lubrication by first drilling a #30 hole into a wood block, making the hole deeper than the length of the rivet. Insert the rivet, then tap the mandrel to expose a gap as shown in Figure 3. Place a drop of oil or spray lubricant in the gap then tap the opposite end to close up the gap.


VIDEO
FIGURE 3: LUBRICATING CHERRYMAX RIVETS



5.4 (continued)

CHERRYMAX RIVET INSTALLATION

CHERRYMAX CR32XX style blind rivets are aircraft grade fasteners of high strength but only if properly installed.

NOTE: To achieve maximum rated strength use only the manufacturer's recommended method of installation. The *CHERRYMAX Process Manual* was the source of information for Tables 1, 2 and Figures 3, 4 and may be viewed and/or downloaded at: <http://www.cherryaerospace.com/files/pdf/catalog/CA-1015.pdf>

KEY POINTS TO REMEMBER:

RIVET SIZE

Rivets must be accurately sized for each application. Proper grip length selection is critical. Only use the rivet lengths called out in the builders manual.

RIVET HOLE

Rivets require close tolerance holes in parts where they are being installed. See Table 1.

TOOLS

CHERRYMAX rivets require a greater stem pull force than common blind rivets but can still be installed with most common blind rivet installation tools. Though the PRP-26A tool recommended for RV-12 construction is not compatible with CHERRYMAX rivets neither is an expensive Cherry brand tool required.

ALIGNMENT

Unlike other blind rivets used in RV construction the CHERRYMAX stem cannot be pulled at an angle relative to the rivet axis. If stem is not pulled straight (parallel) to rivet hole axis premature stem breakage can occur resulting in a rivet that has not fully formed or locked.

DRIVING ANVIL

This small washer like device located above the manufactured head is a critical component of the installation process and **must not be removed**. It will detach on its own after the stem breaks. See Figure 1.

RIVET DIAMETER	DRILL SIZE	HOLE SIZE	
		MIN.	MAX.
- 4 (1/8")[3.2mm]	#30	0.129[3.3mm]	0.132[3.4mm]

TABLE 1:

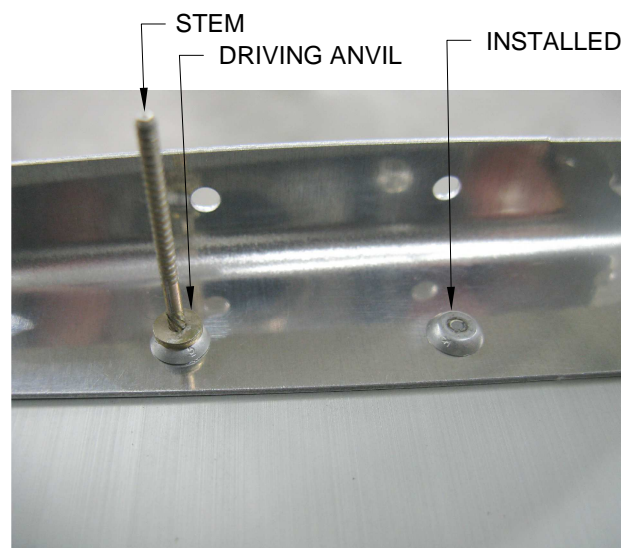


FIGURE 1: MANUFACTURED HEAD

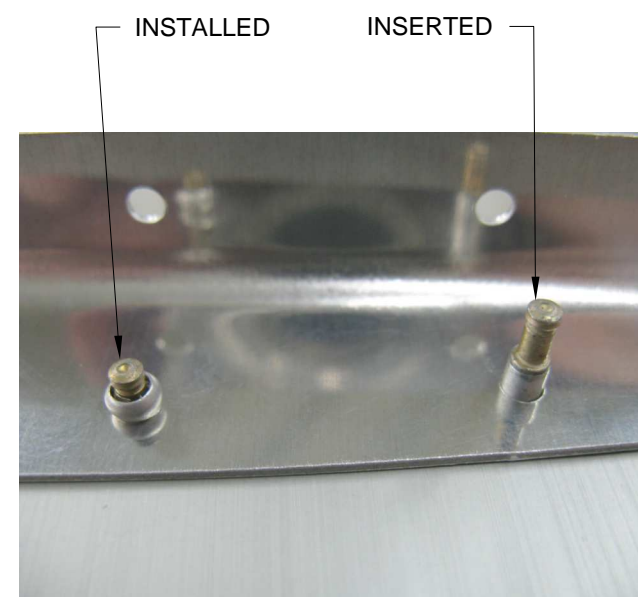


FIGURE 2: SHOP (BLIND) HEAD

PROPER INSTALLATION

Step 1: Verify tool and CHERRYMAX rivet compatibility by performing a test on an easily removed rivet, in the event that removal becomes necessary. For removal see the *CHERRYMAX Process Manual* mentioned earlier.

Step 2: Verify correct rivet grip length. The grip range of all CHERRYMAX rivets is in increments of 1/16"[1.6mm], with the last dash number indicating maximum grip length in 16ths (CRXXXX-X-MAX GRIP LENGTH). Example: -5 grip rivet has a grip range of 1/4"(.250)[6.4mm] to 5/16"(.313)[7.9mm].

Step 3: Insert rivet in hole and verify manufactured head fits square and flush to material surface. See Figure 1.

Step 4: Slip tool over rivet stem.

Step 5: Operate tool while taking care to not lean tool or bend rivet stem while doing so. Continue to pull rivet stem until it snaps free as shown in Figure 1.

Step 6: Inspect rivet to confirm proper installation per the following criteria:

Nearly flush surface due to stem fracture at top of manufactured head. See Figures 1 and 3.

Typical fastener flushness acceptance criteria is shown in Figure 3 and listed in Table 2. Locking collar is to be flush with top surface of rivet head. Collar flash permissible is .020 max. Stem flushness shall be as indicated.

Base of manufactured head should be tight against surface of material being riveted. See Figure 1.

Stem will not be pulled fully into rivet body at shop head end, but rivet body should have formed (closed up) around stem. See Figures 2 and 4 for acceptable blind head formations.

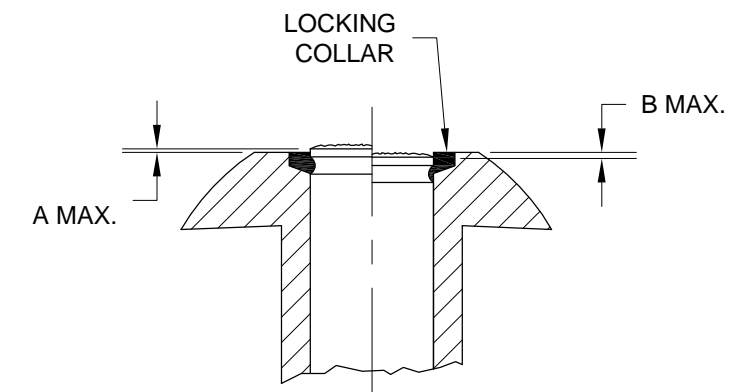


FIGURE 3: FLUSHNESS
(RIVET CROSS SECTION - NOT TO SCALE)

RIVET DIAMETER	A MAX.	B MAX.
- 4 (1/8") [3.2mm]	.010 [.25mm]	.015 [.38mm]

TABLE 2:

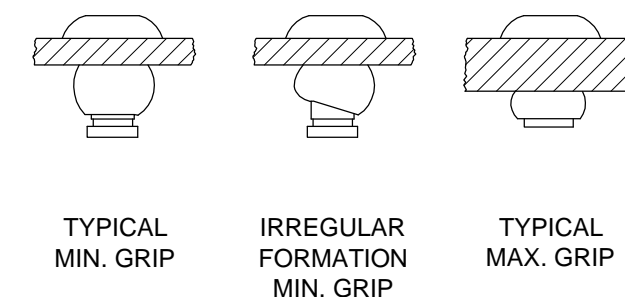
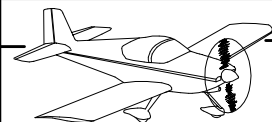


FIGURE 4:
ACCEPTABLE BLIND HEAD FORMATIONS



5.5 COUNTERSINKING AND DIMPLING

Flush riveting requires that a flat or "mushroom" set be used and that the skin around the rivet hole be countersunk either by dimpling or machining. Be sure to remove any vinyl coating before machine countersinking or dimpling the parts. Dimple countersinking will be simply referred to as dimpling for the remainder of this manual.

For AD3 rivets, a total material thickness between .016 [.4 mm] and .032 [.8 mm] must be dimpled. Material thickness between .032 [.8 mm] and .040 [1.0 mm], should be dimpled, but a countersink may be used if necessary. Finally, for a thickness of .050 [1.3 mm] and above the material must be countersunk.

For AD4 rivets, .050 is the minimum thickness that may be countersunk.

Metal thicker than .040 is difficult to dimple, so it is common practice to machine countersink any material thickness that is more than .040. There are a couple of reasons for this. First, although RVs are designed so that a countersunk joint is acceptable, the interlocking nature of a dimpled rivet line is stronger. Second, dimpling leaves a thicker edge for the shop head of the rivet to form against, meaning that the metal deforms less and there is less chance of "working" rivets later.

This recommendation is meant as a guideline, not an absolute rule. There may be instances where countersinking 0.032 stock makes the job easier, and certainly can be used. One example is when a sheet is sandwiched between two other sheets. In this case, the sheet receiving the rivets manufactured flush head is dimpled, the sheet underneath is machine countersunk to receive the dimple, and the third sheet is left full thickness. When countersinking the second sheet you must go slightly deeper than you would for a rivet. See Figure 1.

There are a few instances on RVs where it is considered acceptable to enlarge holes when machine countersinking. Primarily this is done to countersink for the installation of flush screws. It is also done where multiple layers are already riveted together, and on material that is too thick to dimple, such as a wing spar flange.

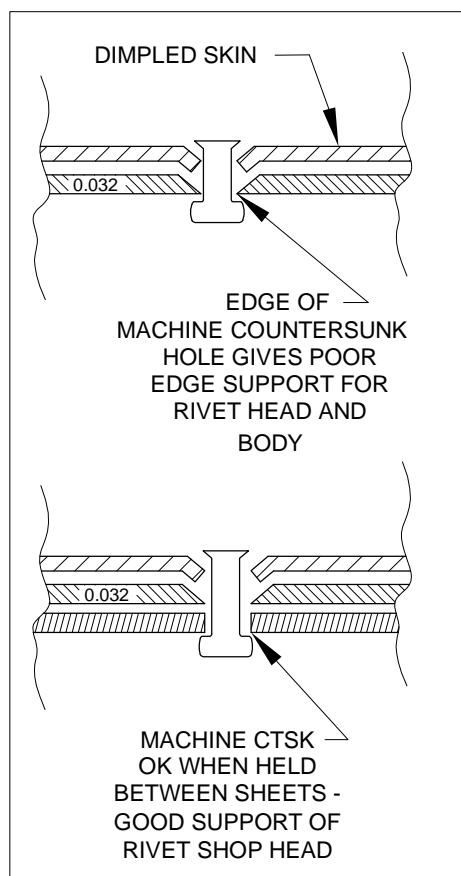


FIGURE 1: DIMPLING

MACHINE COUNTERSINKING

Machine countersinking removes metal and is done with a stop countersink tool and a drill motor. Machine countersinking can only be used in areas where the skin thickness is sufficient. **CAUTION: Check the machine countersink depth frequently since variation in part shape, hand pressure, and tool sharpness will cause the depth to vary.**

Where the skin thickness is insufficient, the countersunk hole for the rivet head enlarges the original rivet hole and no longer supports the shaft of the rivet. Only a portion of the rivet head is now contacting the skin, so it cannot achieve its design strength which is based on full head contact. See Figure 2, Example 1.

When using the minimum acceptable thickness, the full rivet head is supported and the original hole is not enlarged as shown in Example 2. Example 3, shows not only the fully supported rivet head, but also contact with the rivet shank.

Use the appropriate rivet or screw as a gauge when you machine countersink. Stop when the rivet or screw is flush. For a dimpled skin riveted onto a machine countersunk surface the countersink must be slightly deeper as mentioned earlier. Proper depth is .007 deeper than when the rivet head is flush. This depth correction corresponds to seven "clicks" on a microstop countersink tool indexed in .001 inch increments.

When countersinking for a #8 (or larger) screw, the countersink cutter is removing so much material that it can easily "chatter" resulting in a rough surface finish and an out-of-round countersink. A good process for obtaining a smooth finish is to set the microstop countersink tool .005 inch short of the final depth, make the first cut at a slow speed applying heavy pressure, readjust the microstop to the final depth, and make the final cut at high speed applying light pressure.

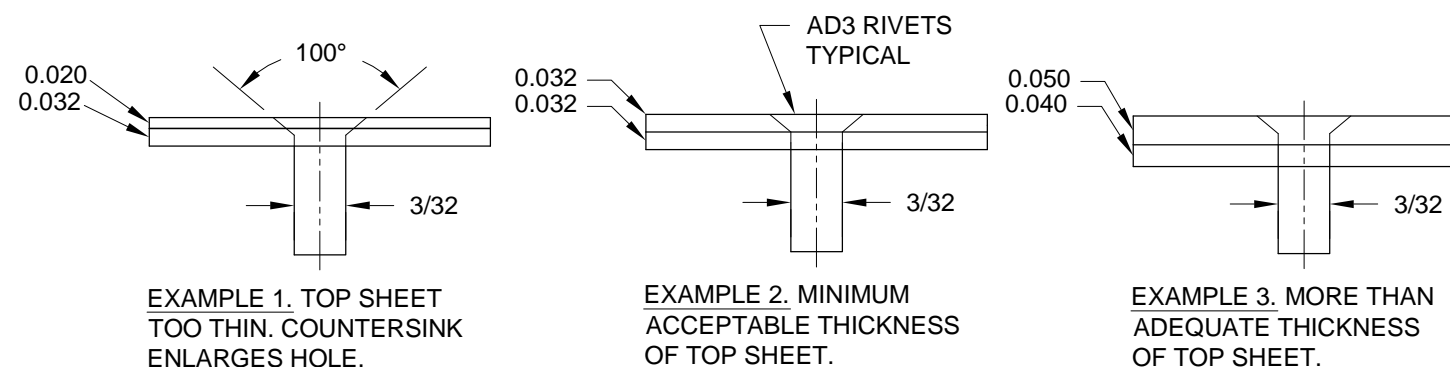
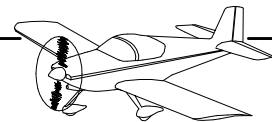


FIGURE 2: RIVETS AND SHEET THICKNESS



5.5 (continued)

DIMPLING

The dimple dies can be used in most tools traditionally used for riveting such as hand and pneumatic squeezers and special dimpling tools such as one commonly referred to as a C-frame, which is used for dimpling in the middle of large sheets.

It is fully acceptable, and common practice, to use a rivet squeezer (hand or pneumatic) to dimple substructure that will be covered up, since the dimples will not be visible.

The best exterior finish quality possible starts with well formed rivet dimples. When dimpling any rivet hole that will show on the exterior it is best to only dimple with a C-frame or other tool that can produce crisply formed, quality dimples. Most rivet squeezers (particularly a hand squeezer) cannot deliver comparable results especially on the large dimples required for flush screws.

When dimples are not fully formed, the aluminum skin around the perimeter of the dimple (approx. .5 radius from hole center) will have a dished shape. Once you learn what to look for, this can easily be detected with your eyes by evaluating the reflection in the skin surface. When viewing the reflection of an overhead light source across the top of a dimple, the only place the reflection should be distorted is inside the dimple. The skin should look clear and distortion free all around the perimeter of the dimple. Under-formed dimples are a rather common problem. Fortunately it is difficult to "over do it" by hitting the arbor too hard when using a C-frame tool for dimpling, that is unless extreme force is used which may cause localized stretching of the material.

When correct technique is used dimple dies will scuff the surface of the skin within the entire die contact area. This scuff mark indicates the dies have fully seated together with the aluminum material tightly sandwiched between them. On the contrary if only a circular ring (formed by the dimple die outer diameter) is present on the skin surface the dimple has not fully formed. The amount of force required to accomplish this varies, depending upon material thickness and dimple size. Thin material like .016, and small dimples require much less force than .040 material and a #8 screw dimple.

It takes practice to learn good technique. The goal is learning how to judge when a dimple is well formed. When using a C-frame tool listen for the sound produced when striking the arbor. The sound of fully seating dies is different from the sound of not fully seating dies. This sound varies depending upon the type of hammer used, but there is always a noticeable difference.

The dimple countersinking process stretches the metal around the perimeter of the hole being dimpled. It is very important that holes drilled to final size be well deburred beforehand to reduce the likelihood of cracking. The bigger the dimple, the more stretching occurs and the greater the chance of cracking.

DIMPLING WITHOUT DRILLING OR DEBURRING

Van's produces two aircraft kits with the holes punched final size (the RV-12 and RV-14*). No deburring is necessary, simply dimple the holes and then assemble the parts. These final sized holes are manufactured using specific tooling and tight tolerances to work with all commonly available dimple dies. By "work with" we mean that the holes may be dimpled without fear that the hole would crack prematurely before the expected fatigue life of a conventionally drilled, deburred and dimpled hole. The cost of tooling to produce these holes and quality checks to ensure that they are being produced correctly results in more expensive parts, that are quicker to assemble.

The other matched-hole kits from Van's use a different set of tooling and looser tolerances. The quality of the hole is not checked as closely on these parts because the customer is expected to clean up the hole to final size with a drill. Forcing a dimple die through an undersized hole will stretch the edge of the hole, and possibly shorten the fatigue life. Testing has shown that use of some dimple dies with properly sized holes can produce an acceptable solution. If the builder does this, a quality check on each hole as they are dimpled is necessary to ensure no cracks. Van's cannot control the size of dimple dies used, and for cost savings does not tightly control the hole size on parts that are expected to be drilled to final size. So we cannot make a blanket statement of approval for any method other than drill, deburr and dimple. Dimpling these parts without drilling to final size and deburring is at the builder's risk.

* There are a few understructure parts from the RV-10 that are used in the RV-14 and undersized. Instructions in the manual instruct the builder to upsize the holes to #40 or #30 and deburr before dimpling.

5.6 BACK RIVETING

When riveting thin aluminum skins to light ribs or stiffeners, it is difficult to avoid getting some slight indentations in the skin around the rivet. Particularly on shiny, unpainted aluminum, reflections make the skin look much rougher than it actually is.

One way to lessen this effect is "back riveting." Back riveting means holding the bucking bar on the *factory head* of the rivet and driving instead from the shop end with the rivet gun and a special back rivet set. The basic back rivet set has a spring loaded sleeve that helps keep the metal pieces firmly together, and prevents the rivet set from accidentally slipping off the rivet.

Back riveting works well for all of the moveable control surfaces where skins are the lightest and riveting distortion and/or skin damage potential is the greatest. Back riveting is also possible on some wing skins and most of the fuselage skins. This is a two person job and requires bucking bars which are larger than those typically used with specialty back riveting sets. We use this procedure extensively in our own shop.

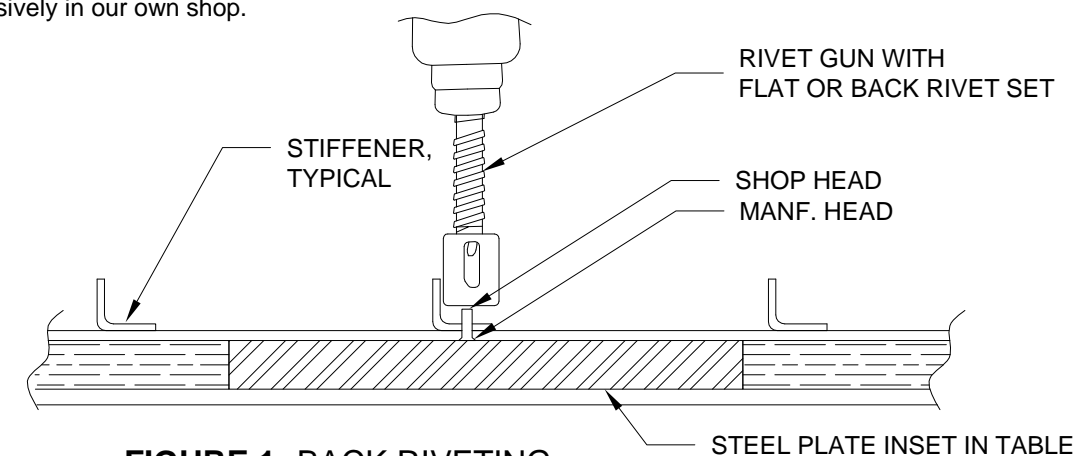


FIGURE 1: BACK RIVETING

5.7 FOLDED TRAILING EDGES

The shape of control surface trailing edges affects the "feel" and performance of the aircraft's controls. This cannot be over stressed. For proper handling qualities and trim, all surfaces should be checked and adjusted before the first flight. Many flying RVs have had bad roll trim or stability issues completely resolved just by using a straight edge to check and adjust all of the control surfaces.

On surfaces having folded trailing edges the skins are provided partially pre-bent. This allows room to install stiffeners and end ribs. Plans pages will have detail drawings depicting the proper radius for the final bend.

A homemade bender can be fabricated from a pair of 2X8 boards and a number of door hinges to achieve the final bend. See Figure 2.

Prior to final riveting, place a dab of RTV or tank sealant about the size of a wad of chewing gum at the inside of the skin where the two stiffeners overlap near the trailing edge. This will tie the stiffeners together and prevent the skins from cracking at this point due to vibration.

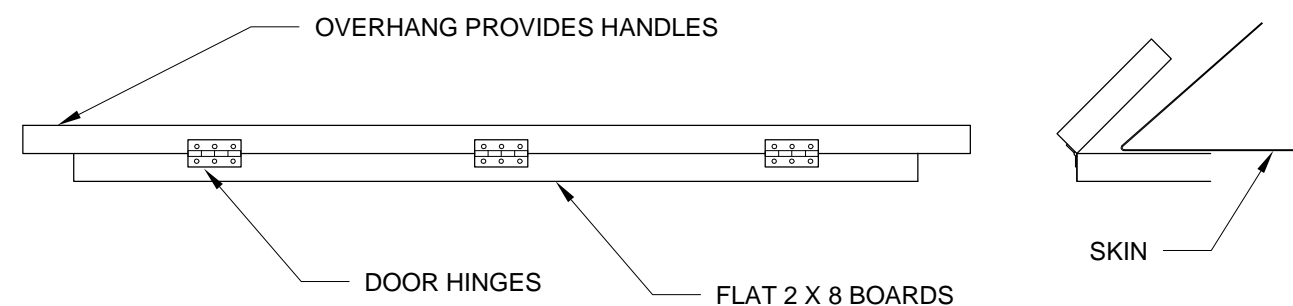


FIGURE 2: HOMEMADE BENDER



5.7 FOLDED TRAILING EDGES (continued)

After riveting the stiffeners in place and bending the skins, check that both sides of the skin are flat and form a straight line from the spar to the tangent point of the trailing edge radius. Avoid bulged or over-bent trailing edges. See Figures 1-3.

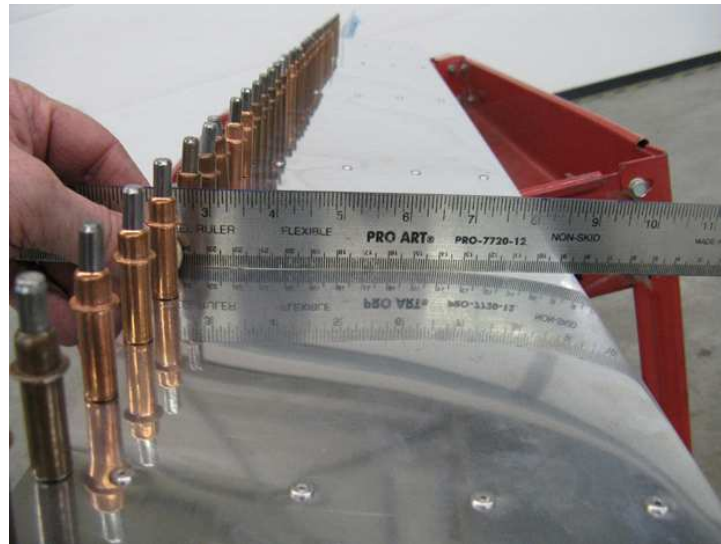


FIGURE 1: BULGED (UNDER BENT) TRAILING EDGE

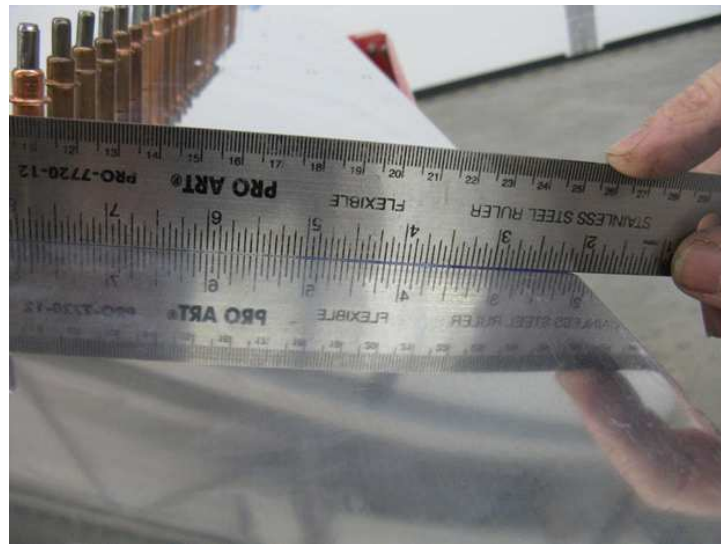


FIGURE 2: PROPERLY BENT TRAILING EDGE



FIGURE 3: OVER BENT TRAILING EDGE

For adjusting bulged trailing edges fabricate a squeezing tool like the one shown in Figure 4. Join two 1X2X6 hardwood blocks with wire springs made from welding rod or left over hinge pin. The wire will help maintain the block's alignment. Note the shallow radius formed at each end so that the sharp edge at the end of the block will not put a crease in the skin.



FIGURE 4: TRAILING EDGE TOOL

To add additional bend (remove bulge), position the tool as shown in Figure 5 then squeeze the trailing edge (TE) using large channel-lock pliers. Large channel-locks provide a lot of leverage which allows for very fine control.

Apply many small squeezes moving the tool at least an inch or so after each one. Work back and forth along the TE checking the skin often with a straight edge and adjusting local areas as needed until the entire control surface is uniformly flat. Occasionally it is difficult to completely finish the bend in areas where stiffeners or ribs are located.



FIGURE 5: TRAILING EDGE TOOL APPLICATION

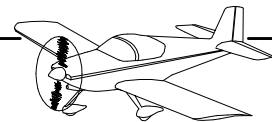
Correct, or "un-squeeze", an over-bent TE using another wood block as shown in Figure 6. Again, put a large radius taper on each end of the block as was done on the squeezing tool.

Move the tool back and forth along the TE of the over-squeezed area while lightly tapping with a hammer. If no change results... tap a little bit harder.

It is best to do this adjusting before the control surfaces are painted because some paints are hard and can crack from the flexing. If adjustments are needed on surfaces that have been painted glue thin felt to the wood blocks to protect the paint finish.



FIGURE 6: "UN-SQUEEZING"



5.8 RIVETED TRAILING EDGES

Control surfaces with riveted trailing edges have a wedge shaped filler piece whose cross-section and degree of pre-fabrication may vary. Whether or not the part comes pre-drilled it will need holes and these holes will need machine countersinking in order to receive a dimpled skin. A simple method of accomplishing this is detailed below. Some set up time is required but with a little planning ahead a number of these pieces may be done at one sitting resulting in a big time savings.

To avoid confusion the wedge shaped filler piece will be referred to here as "wedge" and the trailing edge in general as "TE." Use scrap aluminum strips that are thinner than the max. thickness of the wedge to be countersunk. Cut a small V-shaped notch into one strip to prevent interference with the countersink cutter pilot. Position the strips so that the foot of the countersink cage contacts the top face of the wedge squarely (flush) and the countersink pilot aligns with the centerline of the hole pattern. Attach a piece of safety wire or string between the countersink cage and the post of the drill press so that the cage does not spin. Use a low speed setting on the drill press. See Figure 1.



FIGURE 1: GUIDE AND CUTTER SETUP



FIGURE 2: COUNTERSINKING WEDGE

Building a truly straight TE is one of the more difficult things to do in aircraft construction. To help keep the TE straight we advise adhering or bonding the components together before setting the rivets. Use of double-sided adhesive tape makes it possible to keep the wedge aligned all the way through the TE build process. We recommend 3M tape product number F9460PC VHB for this purpose. In the past fuel tank sealant has been used on RVs for this application.

To apply the tape, prep all surfaces to be bonded with isopropyl alcohol, wipe them down and wait until the excess liquid has evaporated. Apply a continuous piece of tape to both sides of the wedge as shown in Figure 3. Avoid touching the adhesive since skin oils can degrade its effectiveness over time. Allow the tape to bond 15-20 minutes before proceeding further.

At this point there are several possible scenarios one may encounter involving the bonding of riveted TEs, but two predominate. They are (A) when one skin will be rolled into place onto another and (B) whenever both skins are already in place at the time the wedge is to be installed.

Scenario A: One skin rolled into place on another.

Once the adhesive on the wedge has had a chance to bond (see above) remove one protective strip from the surface of the tape and adhere the wedge first to the control surface skin that will remain flat. Insert a small number of clecos from the outer skin surface, poking them through both tapes and the remaining protective strip, to aid in aligning the wedge. Use finger pressure to compress the joint and bond the entire length of the wedge to the skin.

Lay the opposite skin onto the wedge using the clecos as a guide. Install enough clecos to the opposite skin to ensure the skin will maintain its correct alignment and then roll the skin back as described in the construction manual. Follow the process described in the manual for completing all of the internal structure riveting. Lower the upper skin when complete. Keep the control surface TE on a flat surface. Use a straight board and small weights to hold the TE straight. Lift the un-bounded skin slightly and begin progressively pulling the backing from the tape. Once the backing is started the skin can stay close to the wedge while pulling the backing out from between. As clecos are encountered remove them before pulling the backing past to avoid tearing. Once the backing is fully removed apply finger pressure along the entire length of the wedge to get a good bond to the second skin. Insert rivets into the TE holes with the manufactured heads oriented up (on a rudder it's builder's choice). The double-sided tape covering the holes should keep the rivets in place though it might be necessary to apply an additional strip of regular tape.

Scenario B: Both skins already in place:

With the skins and wedge prepared as described in scenario A, insert the wedge between the skins. Use several clecos to hold the wedge to one of the skins and maintain alignment. Peel the backing from the side that corresponds to the un-clecoed skin, clecoing and pressing the skin in place on down the length of the TE. See Scenario A for the remainder of the process for the second skin.

Now for the riveting. Trailing edges are riveted with "double-flush" rivets. These are standard rivets, but instead of setting the shop head on a flat surface, it is set in a dimple and ends up flush with the skin surface. However, a double flush rivet will not look the same on both sides. The factory flush head will set almost perfectly flat. The finished shop head will be flush with the skin, but it will not fill the dimple completely. This has been described as "an acorn sitting in a dimple." Do not fall into the trap of trying to use a longer rivet to "fill the hole." Rivets used in this manner will bend over instead of setting properly and the force involved in trying to drive more rivet material flush into the dimple will cause puckering and waviness.

Place blocks on either side of the back riveting plate, to allow the control surface to lie flat as it slides over the plate (Note, because RV rudders vary in cord and thickness from top to bottom, the skins are not entirely flat so they can not be laid flat on a table. Instead, position the rudder so that only the aft couple of inches are on the back riveting plate and spacers. Then place shims under the spar as needed.) Weight the control surface down to the work surface so it remains straight while riveting.

Starting at the **MIDDLE** of the control surface, to minimize pillowing, back rivet about every tenth rivet just enough to lock everything in place. Do not set the rivets all the way yet. Continue with the remaining rivets by doing one rivet midway between others that have already been done, and working back and forth along the trailing edge until all are initially set.

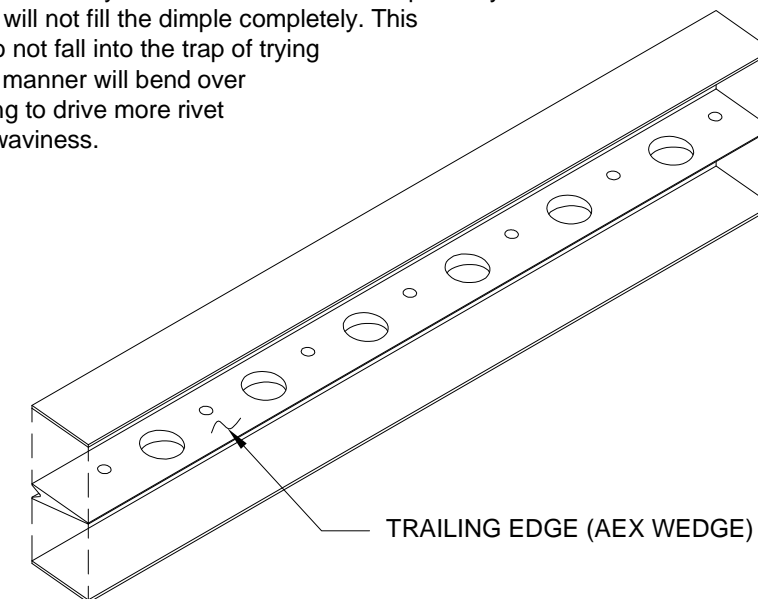


FIGURE 3: DOUBLE-SIDED TAPE



5.8 RIVETED TRAILING EDGES (continued)

Set the rivet gun pressure low (it should take about three seconds to fully set a rivet). This will allow time to vary the angle of the rivet gun while driving the rivet. Start with the rivet set parallel to the rivet shank and tilt it to set the rivet flush to the skin as the rivet sets. Repeat the initial pattern until the rivets are completely set. See Figures 1 and 2.

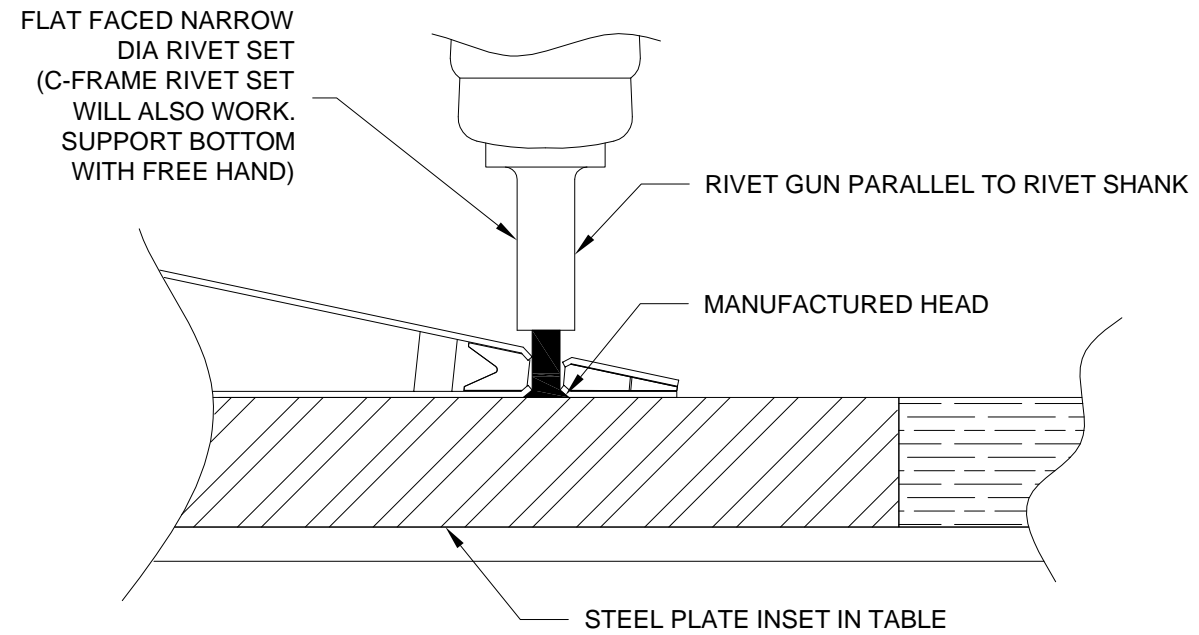


FIGURE 1: RIVETING THE TRAILING EDGE, INITIAL

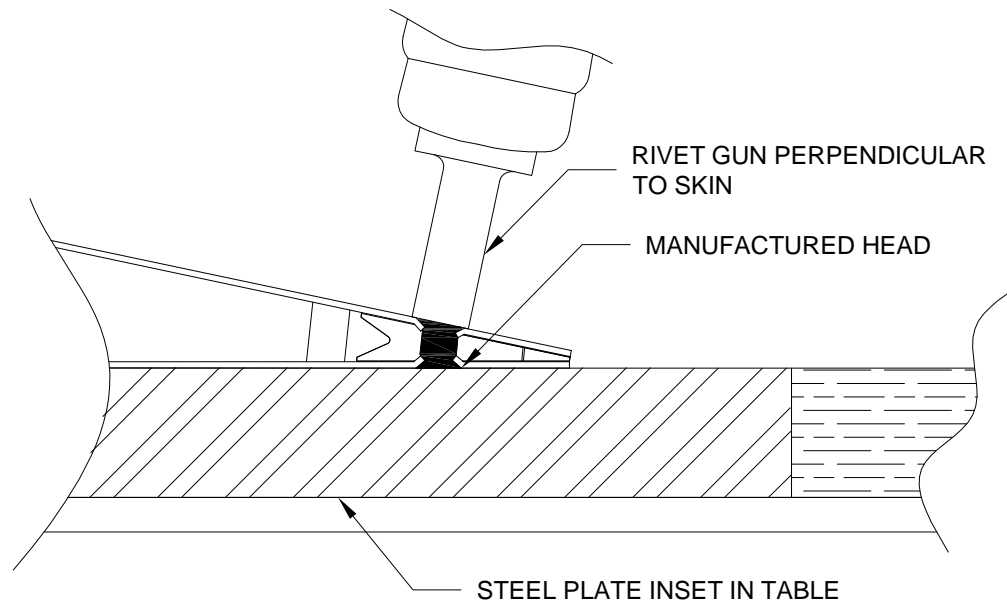


FIGURE 2: RIVETING THE TRAILING EDGE, CONTINUED

Check constantly for any deformation of the trailing edge. If deformation over 1-2 in. [2.5-5 cm] in length is observed place blocks near the curved area and lightly bend the trailing edge back down. Take your time and work as precisely as possible. An excessively wavy or bowed trailing edge will affect the flying qualities of the airplane. Strive to build a trailing edge that does not vary more than the dimension called out in Figure 3.

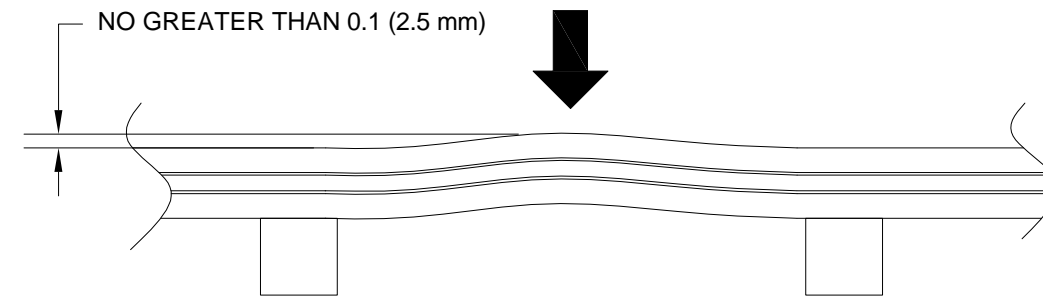
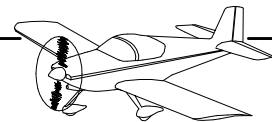


FIGURE 3: STRAIGHTENING THE TRAILING EDGE



5.9 ROLLED LEADING EDGES

Before the empennage control surfaces can be installed on the stabilizers, the leading edges must be formed. The object here is to achieve a smoothly curved surface that fits neatly between the skin overhang of the stabilizer.

Simply pulling the overhanging skins together results in an angle or crease where they cross the edge of the spar. To avoid creasing the skins the curve is started by rolling the edge of the skin. A piece of 3/4 or 1 inch diameter steel water pipe, a broomstick, or something of similar diameter about four inches longer than the skin will be needed.

Tape the edge of the skin to the pipe along its entire length. Use vise grips or a small pipe wrench clamped to the pipe as a handle and roll the skin around the pipe. Maintain pressure down toward the work surface and away from the spar to prevent the skin from bending right at the spar. This will not produce the final shape, but it will produce a curve in the skin that allows the skin to be closed with a minimum of spring-back. If working solo, it will be easier to use a shorter pipe and do each skin section individually.

NOTE: Not fully forming the skin, but instead just pulling the two halves together and riveting, causes a lot of pre-load on the skin and is a common cause of skin cracking at the forward end of the skin stiffeners.

Finish the bend by hand, squeezing the skin until the holes match. Drill the holes full size then clean up the holes (it is hard to get to the inside of the curved skin with a deburring tool, but in this case a quick rub along the holes with a scotchbrite pad is good enough) and rivet. Blind rivets are used here. They are simple to set with a hand pop-riveting tool, but difficult to drill out. Make sure that the heads of the rivets are firmly against the skin before squeezing. See the Leading Edge Detail on the appropriate drawing.

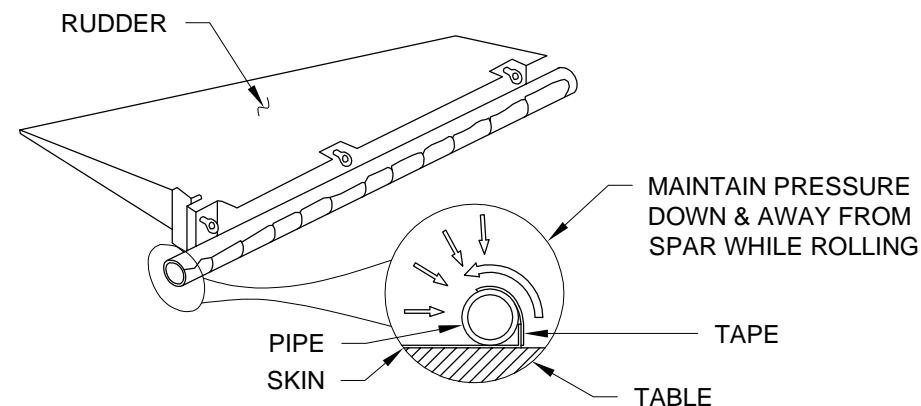


FIGURE 1: ROLLED LEADING EDGES

5.10 LAP JOINTS

When riveting a lap joint, the expansion of the aluminum caused by the setting pressure and the expansion of the rivet causes the overhanging edge of the sheet to bend upwards slightly. This creates a number of problems, like making the lap joint appear wider than it is, making painting more difficult, etc. One easy method of minimizing this effect is by pre-bending the last 1/4 inch of the skin downward just a small amount before it is clecoed and riveted. When the rivets are driven, the skin will be flattened and the pre-set in the skin edge will tend to hold it flush. Except for very rare circumstances, the amount of bend (break) is very small and when done properly is almost undetectable with your eye. The goal is to do just enough to keep the skin lying flat but not too much or it will be obvious that it was done.

There are several methods that may be used for making this slight edge bend. Using a hand seamer and moving progressively down the sheet, making a very light bend to avoid bend marks between succeeding grips with the seamer. On long thin pieces put the sheet on an even-edged table with about a 1/4 inch overhang and draw a block of hardwood or plastic along the edge with just enough downward pressure to cause the slight bend as the block moves. UHMW blocks with different depth slots to set the bend depth may also be used. Slip the slot over the skin, apply a bending force and pull the block towards you, sliding it along the edge of the skin. Do not try to form the bend all in one pass.

Some tool suppliers sell tools for this purpose, usually two small rollers mounted on a variety of different tools. The edge of the aluminum sheet is placed between the rollers and a bending pressure is held as the tool is drawn down the edge. Use these with caution as they may tend to stretch a long edge and make it wavy. Avoid over bending the edge and causing a worse visual effect than before. Experiment with scrap material first.

5.11 FORMING ALUMINUM PARTS FROM SHEET

Some of Van's kits require forming several ribs and bulkheads from flat aluminum sheet. This can be a useful skill in the Standard kits as well. Sheet metal press brakes are only capable of producing straight bends, so parts with flanges along curved edges must be bent over "formblocks."

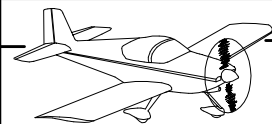
formblocks are made of hardwood or dense particle board. They are cut to the contour of the finished part with allowances for the thickness of the material. Edges are radiused so as the part is bent around the block, it does not bend too sharply and crack. A blank part, with the appropriate material for flanges, notches at the corners, etc., is cut from sheet stock and sandwiched between the formblock and a "tool cap". This tool cap looks very much like a formblock, but does not have to be exact.

The tool cap functions to keep the part from bowing or distorting when the flanges are bent. The formblock, blank and tool cap are all aligned with tooling holes and clamped together with bolts. The protruding edge of the blank part is bent around the formblock with a mallet or lead bar. Final adjustments to the flange are made with a hand seamer and fluting pliers.

5.12 VINYL COATING

Many of the alclad parts are supplied with a thin (usually blue) vinyl coating to prevent scratching during the manufacturing of the parts. The vinyl may be left on during drilling but should be removed for dimpling, priming and final installation. It is possible to remove strips of vinyl along rivet lines with a soldering iron. Carefully round and smooth the tip of the iron so it will not scratch the aluminum. The time in labor required for this added protection during construction should only be considered of value if you intend to leave the airplane polished bare aluminum. If you intend to paint, the preparation process will include scuffing/deglossing all of the skin surfaces anyway to provide good paint adhesion.

The adhesive on the vinyl strengthens with age, so if the coating is left on for more than a few weeks, it may become very difficult to remove. Corrosion has been found under the vinyl in some instances. If vinyl covered parts must be stored for long periods remove the vinyl first.



5.13 FLUTING

There are some conventions when referring to parts of parts. Terms like "flange" and "web" have specific connotations and using them correctly makes the job of Van's Builders Support personnel much easier. See Figure 1.

Verify that the flanges on parts are perpendicular to the web (unless otherwise specified), so that they will mate correctly with the skins. Adjust flanges with hand seamers or small wood blocks with slots cut in them as necessary. A pair of duck bill pliers can also be very handy for adjusting small flanges.

The process used to manufacture parts with curved flanges will leave them slightly bowed and sometimes twisted. Before parts are installed the flanges must be straightened (any twist in the part can be ignored). This is done by "fluting", that is, putting small creases or "flutes" along the edge of the flange with special pliers. The flutes effectively shrink the flange material and pull the part into line.

Fluting diagrams are shown on the plans where required. Otherwise the flutes are simply centered between the pre-punched holes in the flanges. When making flutes, be sure they are formed towards the inside of the part so that the outer face of the flange remains flat for the skin to lie on.

Straighten the ribs/bulkheads with fluting pliers and check for straightness by sighting down the web or by laying the part on a flat table top. On parts with prepunched holes, a straight edge can be used to check that the prepunched holes are aligned. The more curve that a flange has, the more fluting that will be required. On parts with a varying amount of curve (such as a wing rib), a different amount of fluting will be required in different areas of the part. Do a little at a time until reaching the desired flatness.

NOTE: Do not confuse the twist in a part with a curved flange. It is normal for light pressure to be required to hold a twisted part flat on a table. Fluting does not remove twist from a part.

If you have overdone the flutes and curved the rib or bulkhead the other way, gently squeeze the flutes with smooth pliers to straighten the ribs.

5.13.1 STRAIGHTENING THICK ALUMINUM PARTS

NOTE: Some thick (.125 [3.2 mm] or thicker) aluminum parts, such as the (F-01411C Horizontal Stabilizer Attachment Bars in the RV-14) may be bowed due to the punching operation used during their manufacture. Use the following process to straighten any other thick aluminum part prior to installation.

Clamp one end of the part in a padded vice (padded with wood, aluminum, etc).

Pre-load the free end of the attachment bar in the direction required to straighten it. Using a rubber mallet, firmly strike the part once near the vice.

Slide the part further into the vice, pre-load, and strike the bar again.

Repeat as necessary until the part is straight within 1/16 [1.6 mm] along its entire length. See Figure 2.

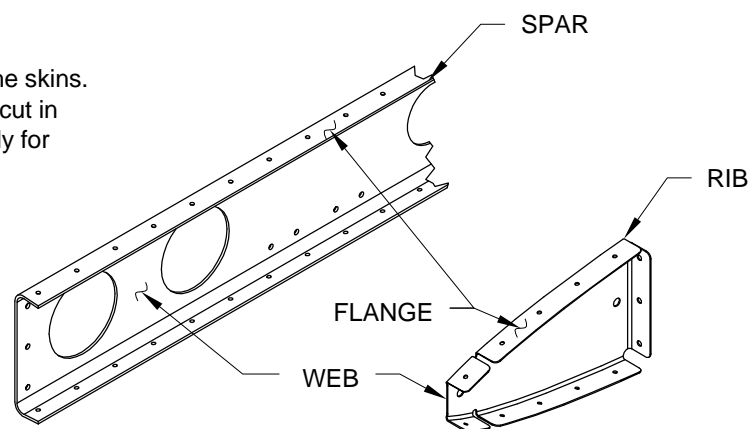


FIGURE 1: BASIC TERMINOLOGY

5.14 ALUMINUM TUBING

In RVs, 3003 soft aluminum tubing is used for the fuel lines inside the cockpit and for the brake lines. These lines must be bent with a tube bender to avoid kinking and to get a professional looking installation. The flared ends of these lines are 37°, not the 45° found on automotive lines. A good quality flaring tool is a necessary tool to do the proper job. Properly installed, aluminum lines will last for many years. Here are a few tips on the "properly" part:

Preparing the tube: Soft aluminum tube should be cut with a tubing cutter - not a hacksaw. The resulting end will be square. After making the cut, deburr the interior edge of the tube end and polish the end of the tube with fine crocus cloth, emery paper, or a Scotchbrite wheel.

Mounting it in the flaring tool: First, put the AN-818 nut and AN-819 collar on the tube and push them out of the way. There is a tongue on most flaring tools that serves as a stop. Make sure you have selected the right diameter (Most RV's use 3/8 tubing for fuel lines and 1/4 tubing for brake lines), insert the tube from the far side of the tool until it hits the stop, then tighten the clamp.

Making the flare: Put a drop of light oil on the cone of the flaring tool. Spin the cone down into the tube and watch it make the flare. Do not over tighten, which can start thinning the material in the area of the flare. Turn the cone just enough to fully form the flare.

Inspect the flare: Take a good look at the stretched aluminum around the circumference of the flare. You will probably see some tiny stretch marks, but there should be no cracks or splits.

Install the tube on the flare fitting: Mate the flared end of the tube with the conical end of the AN fitting. Slide the AN-819 collar down the tube until it rests on the back of the flare. It must be square to the fitting. Any slight angle will make it difficult to start the nut, and if you do get it started, runs the risk of splitting the aluminum flare.

Slide the AN818 nut over the far end of the tube and engage the threads on the AN fitting. Tighten to the specified torque. You should have a Standard Aircraft Handbook with the torque tables for these things. (assuming aluminum fittings, for 1/4 tubing it is 40-65 inch-pounds, for 3/8 tubing it is 75-125 inch-pounds.) Later, you can leak test the system.

5.15 STEEL

Most of the steel used in RVs is 4130 normalized, mostly in the form of thin plate and thin wall seamless tubing. This 4130 high carbon steel is used extensively in the aircraft industry because of its high strength and relatively good workability.

Most steel parts supplied in RV kits are powder coated at the factory, meaning that there is little for the builder to do except install it. On a few parts, where the sequence of welding or forming operations makes powder coating at the factory impractical, the builder may paint the part. The best method of cleaning is bead-blasting, but some work with a stiff brush and solvent will do the job.

Steel parts should be primed and painted immediately after cleaning to prevent rust.

Stainless steel will quickly dull cutting tools (drills, deburring tools, reamers, etc.). Use plenty of lubricant (Van's Aircraft uses Boelube) and keep the cutting speed low. Use a step drill if creating holes over .250 [6.4 mm] in diameter.

Stainless steel edges can be very sharp. Handle with care!

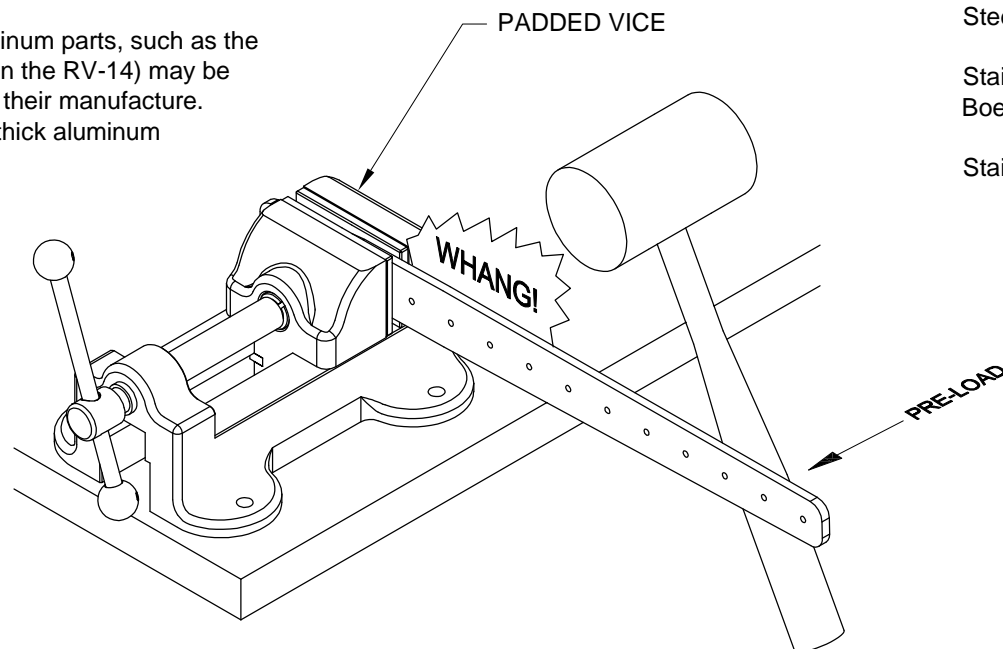
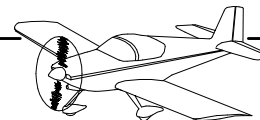


FIGURE 2: STRAIGHTENING A THICK ALUMINUM PART



5.16 INSTALLING NUTPLATES

Nutplates are almost always installed with flush rivets. When the structure is too thin to machine countersink there are two options. The first alternative is to dimple both structure and nutplate. In order to dimple the nutplate it is sometimes necessary to use a reduced diameter female dimple die so it will clear the threaded or countersunk portion of the nutplate. Simply grind away that portion of one side of the die that is in the way. If carefully modified the die will still give good service in dimpling other parts. Only the female half of the die needs to be modified. When installing single leg nutplates (MS21051, etc.), temporarily install a screw to insure it remains aligned while riveting.

The second alternative when attaching nutplates to thin material is to replace AN426 rivets with NAS1097 rivets which require a much shallower countersink and are still acceptable.

Nutplate mounting holes that are not prepunched must be match-drilled using a nutplate drill jig. Commercial nutplate jigs are quick to use but may be unusable in situations with limited access. A compact nutplate drill jig may be fabricated from an appropriately sized nut plate and screw. Insert the screw finger tight in the nutplate and then remove the head of the screw with a hacksaw or die grinder/cutting disk. See Figure 1. This also works well with single leg and corner nutplates.

For application, insert the screw in the screw hole and rotate to the desired alignment. Match drill one of the mounting holes and cleco. Match drill the other mounting hole. When the attach holes in the nutplate begin to get worn/enlarged, replace the nutplate with a new one.



FIGURE 1: NUTPLATE JIG

5.17 FUEL TANK SEALANT

The recommended sealant, MC-236-B2, (often called ProSeal) is available through the VAN'S ACCESSORIES CATALOG. Mixed, unused sealant may be kept in the freezer for up to 4 days.

Although the sealant used to seal the tanks is not particularly noxious, only use it and the solvents used in tank construction with adequate ventilation. Use a respirator, gloves (which also keep oil from your skin off the surfaces to be sealed), and protective cream when sealing the tanks. Why expose your skin and lungs if you can prevent it?

Working with tank sealant can be a messy proposition but it does not have to be. By taking care and thinking things through it can be painless. Handy things to have on hand: disposable surgical gloves, a box of Popsicle sticks, a supply of clean rags, paper towels, butcher paper (not newspaper) to cover the bench surface.

Rough all mating surfaces using a Scotchbrite pad. Don't be bashful; score the aluminum well so the sealing compound will have more surface to grip. After scoring thoroughly clean all parts (including rivets) with naphtha, MEK, or an etching acid like Alumiprep or Twin Etch. After cleaning, do not pollute the areas to be sealed. Don't even touch them. The oils from your skin will affect the bond of the sealant.

The tank sealant should be mixed as accurately as possible. This can be done by using a homemade balance scale, a hand loader's scale, a postal scale or nearly any of the small inexpensive digital scales that are available. Follow the instructions supplied with the sealant. When mixing sealant, do not mix too much at one time. A batch the size of four or five golf balls is usually enough for one work session. The sealant provides 45 to 90 minutes of working time (less in warmer temperatures). To use the sealant as soon as possible after mixing, have all the work well planned and tools all laid out. Have a container of acetone, MEK, or lacquer thinner nearby for the frequent tool cleanings necessary during riveting. You can peel away overflow on areas you want to keep clean by strategically applying plastic tape before spreading the sealant.

APPLYING SEALANT

Use plastic freezer bags. A small amount of sealant can be put in one, the corner of the bag cut off, and the bag squeezed like a cake decorator's pastry bag to apply sealant to parts.

Purchase some plastic disposable syringes from a farm supply store. Monoject 35cc syringes cost very little. Drill the end out a little larger for better flow of the thick sealant. After filling the syringe with sealant using a Popsicle stick and squeezing out the air, you now have a miniature caulking gun.



5.18 FIBERGLASS

Fiberglass Reinforced Plastic (FRP), or "Fiberglass" as it is more commonly known, is used in numerous places in RVs for non-structural parts. These include the cowl, spinner, and other fairings. The typical part consists of several layers of bidirectional fiberglass cloth and resin.

Fiberglass parts supplied with RVs come in two resin types, polyester and epoxy. Polyester parts can easily be identified by their white or gray gel-coat surface. The "wet layup" epoxy parts are translucent green. Some parts (typically large parts such as cowlings) are manufactured from epoxy pre-preg cloth which requires baking in an oven to cure. These parts can be gray exterior, opaque green or pink. They are easily identified by the honeycomb pattern visible on the inside surface of the part. Polyester resin is not compatible with epoxy and can only be used on polyester parts. However epoxy resin is OK to use on either epoxy or polyester parts. Many builders have had good results with West Systems epoxy resin.

Molded fiberglass can be cut, filed, and drilled with any tools used for metal working. Though it is softer than steel or aluminum, glass fiber is very abrasive and will quickly dull tools. Set aside some drill bits for use exclusively with fiberglass. Use sanding blocks and sandpaper rather than files.

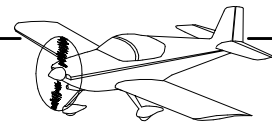
Like welding, fiberglass molding is a specialty skill. Fiberglass parts lend themselves more to production methods than do most other parts. Thus, VAN'S AIRCRAFT offers most fiberglass parts pre-molded. To make the parts that are not supplied in the kit any fiberglass cloth of medium weight will do. Flocked cotton fiber and micro balloons are mixed with resin for building up and filling. Using Peel Ply will result in a very smooth finish that is also ready for glass to glass bonding without sanding. Most supplies can be obtained from a local marine/boat store or from one of the mail order supply houses like Aircraft Spruce.

NOTE: When setting solid rivets in fiberglass composites, use soft rivets or do not fully set normal rivets (shop head height approximately 1.2 X the hole diameter).

PREPPING THE COWLING FOR PAINT

Fit the cowling to the fuselage with all the hinges, retaining screw holes, and nut plates installed, but leave the oil door installation for later.

On older-style pink cowlings that do not have a gray coating, Van's recommends use of a Poly Fiber product called Smooth Prime. We follow the manufacturer's instructions EXCEPT that we apply the first coat straight-out-of-the-can and un-reduced, using a Bondo squeegee rather than a roller or spray gun. Using a squeegee to apply the first coat forces the filler into surface voids.



TIPS FOR FIBERGLASS FAIRINGS

When installing fiberglass tip fairings (especially wingtips), ensure that the trailing edge extension is aligned with the control surface trailing edge. On wingtips, this can lead to inconsistent gaps between the skins and the joggled edges formed into the parts at the factory. For instance, there may be a smaller gap on the bottom than on the top, differing along the length from leading to trailing edge. Once the part has been positioned to where the trailing edges align well and the part has been match drilled and clecoed into position, make sure the metal edges are not riding up onto a fiberglass edge radius as shown in Figure 1.

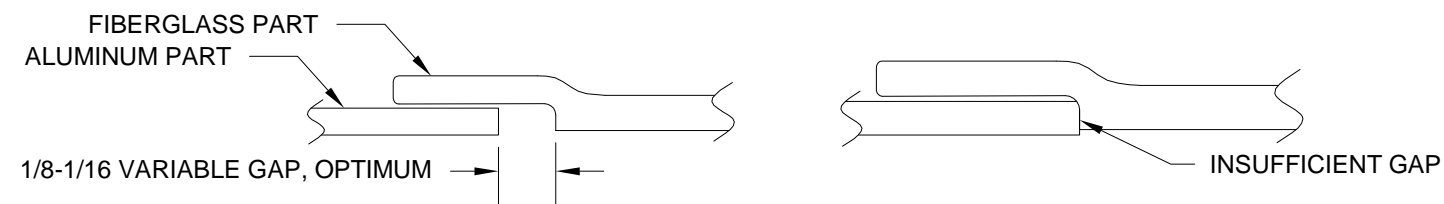


FIGURE 1: FIBERGLASS GAP

After the part is prepped for final installation, either with screws and nutplates or rivets, the gap can be filled using the following steps:

Step 1: Clean the part around the perimeter with solvent to remove any residual release agent.

Step 2: Scuff deeply with coarse sandpaper the recessed area that falls between the normal finished surface and the edge of the metal (through the gel coat will ensure the best possible bond). After scuffing, clean thoroughly.

Step 3: Wrap electrical tape or equivalent around the inside surface of the metal part. See Figure 2. Insert and secure the fiberglass tip with either screws or clecos as appropriate, then finish wrapping the tape snugly around the edge of the metal. The tape will act as a release agent for the next step.

Mix up a small batch of epoxy resin and add floc until it reaches the consistency of peanut butter. Fill in the groove between the tape and fiberglass with this mixture. Ensure that the thickened floc fills in the entire gap. The floc should come up to the level of the tape or slightly beyond so there is room to sand it back down after it has cured.

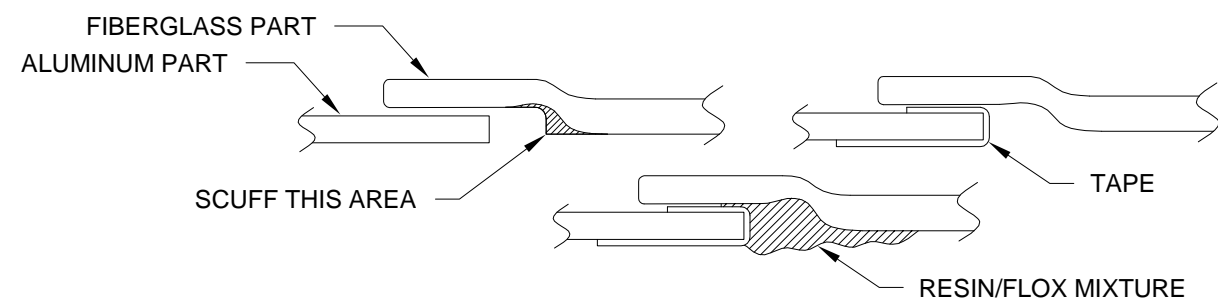


FIGURE 2: RESIN APPLICATION

When the resin has hardened overnight, lightly sand off any mixture that overlaps the tape as shown in Figure 3. Remove the tip and the tape. Complete installation of the tip per kit instructions. The interface can be sanded to leave a perfectly co-planar surface with a consistent gap.

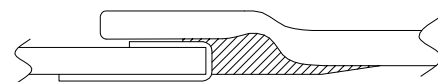
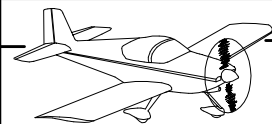


FIGURE 3: SANDING

MIXING COTTON FLOC WITH EPOXY RESIN

Mix cotton floc with epoxy resin. Gradually add floc until the mixture does not move when the mixing container is turned on its side.

The epoxy/floc mixture can be applied using plastic freezer bags in a similar fashion to fuel tank sealant (see 5.17).



MATCH-DRILLING OPAQUE FIBERGLASS PARTS

Tiny defects in the surface of fiberglass parts often result in "pinholes" that appear after painting. In order to reduce this pinhole effect, some fiberglass parts are (now) supplied with a specialized opaque coating. Unfortunately, opaque parts are difficult to match-drill with any accuracy. One possible solution is to use a pair of spherical magnets to locate each match-drilled hole. Magnet kits are included with all kits that contain opaque parts and are also available through the VAN'S ACCESSORIES CATALOG.

The following steps describe the use of magnets when fitting a fairing. These steps supplement but do not replace the instructions in the construction manual. This method can be broadly applied to match-drilling all opaque parts.

1. Tap the holes in the bracket (or structure) where the fairing will attach. If no holes exist, drill #36 and tap #6-32.
2. Thread a screw into and out of each bracket hole in order to verify that the holes were tapped successfully.
3. Place one spherical magnet on each side of each bracket hole so that the magnets rest inside the holes (this allows the magnetic poles to self-align). See Figure 1
4. Tape the inside magnets to the bracket (i.e. the magnets that will be on the inside of the fairing).
5. Remove the outside magnets from the bracket.
6. Align the fairing (if applicable, refer to the construction manual).
7. Place one (#8) flat nylon washer and one magnet against the outside of the fairing at each inside magnet location. See Figure 2.
8. Tape the nylon washers in place. See Figure 3.
9. Remove the outside magnets from the fairing.
10. Remove the fairing from the bracket.
11. Remove the tape and inside magnets from the bracket.
12. Trace the inside diameter of each nylon washer onto the fairing with a fine-point permanent marker.
13. Remove the nylon washers (optional).
14. Drill holes in the fairing at each marked location (drill #27 if bracket holes were previously drilled #36 and tapped #6-32).
15. Attach the fairing to the bracket with screws in order to verify proper alignment. Do not fully tighten the screws.
16. Remove the fairing.
17. Cover the bracket with Mylar packing tape.
18. Aggressively roughen, then clean, the inside of the fairing around the attach holes.
19. Coat the threads of the screws with a release agent (e.g. Boelube, automotive wax, etc.).
20. Mix cotton floc with epoxy resin. See Section 5.18.
21. Build up a layer of epoxy/floc around the holes on the inside of the fairing. Apply enough epoxy/floc so that the bracket will press against the mixture, but not so much that the mixture will capture the inside surface of the bracket. See Figure 4.
22. Place the fairing over the bracket. Flex the fairing apart so that the epoxy/floc mixture does not touch the bracket until the fairing is in the proper position.
23. Attach the fairing to the bracket with the coated screws. Do not fully tighten the screws: allow the epoxy/floc mixture to fill the space between the curved surface of the fairing and the flat surface of the bracket.
24. Remove the fairing after the epoxy/floc mixture has fully cured.
25. Clean up any excess epoxy/floc mixture. Remove the Mylar packing tape from the bracket.
26. Final-Drill and countersink the fairing holes as required.
27. Final-Drill the tapped holes in the bracket and install nut plates.

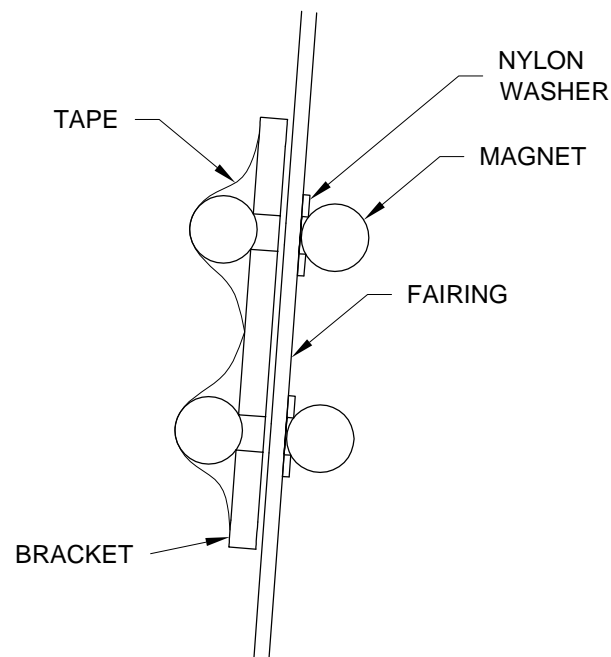


FIGURE 1: MAGNET ALIGNMENT



FIGURE 2: MAGNET AND WASHER



FIGURE 3: TAPED WASHER

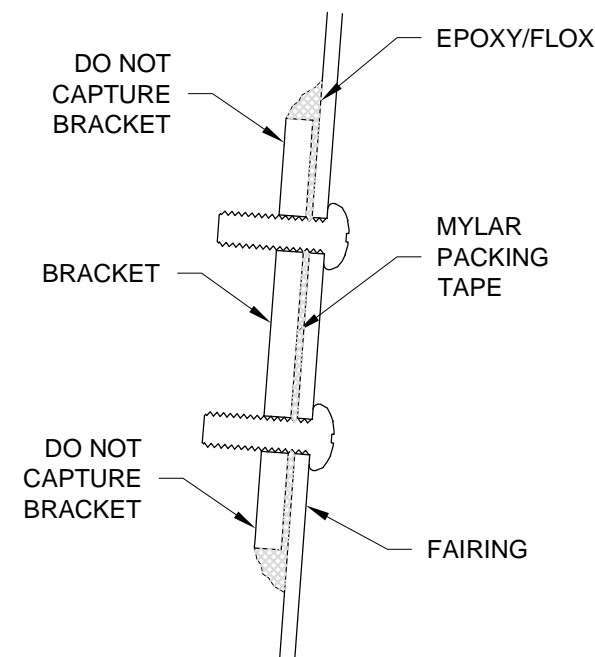
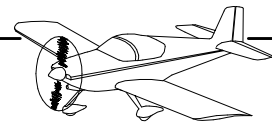


FIGURE 4: EPOXY/FLOC BETWEEN FAIRING & BRACKET



5.19 ACRYLIC CANOPY AND LEXAN WINDOW HINTS

DEFINITIONS

Plexiglas or Poly(methyl methacrylate) (PMMA) is a transparent thermoplastic often used as a light or shatter-resistant alternative to glass. This material is specifically used for canopies and windows contained in RV Finish Kits. Beware of aftermarket canopies made of material other than Plexiglas that promise easy installation because of resistance to cracking yet may not break in a roll over accident and will be difficult to break by hand preventing egress from the aircraft. Lexan or polycarbonate resin thermoplastic is the brand name for polycarbonate sheet and resin in a wide range of grades. This material with a fuel resistant coating is used specifically for the RV-12 aft window. The Plexiglas canopy bubble and Lexan window are two of the most expensive and fragile components in the kit. Mishandling, scratching, or cracking them are some of the most disappointing and gumption-robbing experiences a homebuilder can have. Below are a few general Do's and Don'ts.

SAFETY

Most of us understand the importance of Shop Safety. Eye, ear, and respiratory protection are essential when fabricating Plexiglas and Lexan. Die grinders will cut fingers without a second thought, turn at very high rpm, and can throw chips and dust at un-dodgable velocities. Two hands are recommended to guide this tool. Drill bits can also break and become flying hazards. Eye protection is a must. Remember to support your work well and use gloves when it makes sense.

HANDLING

The canopy is most vulnerable to cracking when moved or flexed before edges or holes have been deburred. Be especially cautious when the canopy is in this state. Plexiglas and Lexan are dramatically less brittle when warm. Do not try to work on these materials in a cold shop. Cutting or drilling the acrylic transparencies in temperatures under 60° F is asking for trouble. Heat the shop to 75-80° -- it may be uncomfortable to you, but your canopy loves it. Many builders will put a small space heater under the canopy when trimming, just as insurance. Take care not to overheat the canopy. Too hot is when any part of the canopy is hotter than "warm to the touch". More than one builder has melted a canopy in an attempt to make sure it is "warm enough". Localized heat is as bad as no heat and can deform the canopy. Be cautious when fitting your canopy over small protrusions and/or transitions in canopy frame tubing diameters. You might elect to shim the tubing surfaces so that the acrylic is not pinched or bridged over any given area.

CUTTING

CAUTION: DO NOT use a saw of any kind. You might get away with it once or twice, but eventually you will crack the canopy.

Cutting discs, supplied with the kit, do an excellent job when used in a high-speed die grinder. If a die grinder is not available, an electric drill will work, but several passes will be necessary, going a little deeper each time to complete the cut. Practice on the flanges of the canopy for both the cutting and drilling operations. Work slowly at first pass to begin cutting an initial slot and to gain confidence with the procedure. Once the initial slot is made, continue cutting through the material. Once cut, the edges should be smoothed and rounded with a scraper. For a scraper use an edge from a pair of quality scissors. Do not leave the edges rough. Ensure that no edge has a sharp corner.

DRILLING

Special Plexiglas/Lexan drills are available from tool suppliers. Van's recommends two such tools; Diamond Dust drills and Unibits. Clamping a piece of wood behind the acrylic material and drilling through into the wood can eliminate chipping on the backside of drilled holes. Start drilling the warmed acrylic with slow speeds and light pressure. Increase speed and pressure as you progress. As the drill bit starts to go through the canopy, reduce speed and pressure so that the drill bit penetrates the opposite surface slowly. It is important to deburr both sides of the hole lightly with a machine countersink. No hole should have a sharp corner. Practice drilling holes in scrap pieces until you are familiar and confident with the process. It is worth remembering that excessive heat caused by machining and drilling *may* alter the acrylic's properties which may in turn allow even approved products to negatively affect the material. For this reason it is important to cut slowly and avoid overheating the acrylic. To enlarge holes the use of a step-drill (Unibit) or reamer is recommended.

CAUTION: DO NOT use a regular twist drill! A twist drill tends to fracture the acrylic due to its tip design. Using a regular twist or plexi drill to enlarge a pre-drilled hole is not recommended and will practically guarantee a cracked canopy as a result.

FIBERGLASS BONDING, CRACKS, ETC.

CAUTION: DO NOT use Polyester resin of any type, as it will cause crazing .

Be certain to use ONLY epoxy resins. Do *not* use the more common polyester or vinyl ester resins since they are not compatible with Plexiglas and cause crazing that will ruin the canopy. We have had excellent results with West Systems Epoxy products, available from boat yards and mail order houses.

The three keys to getting a good bond between fiberglass and acrylic canopies and windows are proper surface prep, proper surface prep, and proper surface prep. The bonding surface must be entirely de-glossed. Many builders think they have scuffed the surface well, when it is not nearly enough. Fully scuff the surface using 60 - 80 grit sandpaper. Use an overhead light source to inspect the surface carefully. Look between the scratches... there should be absolutely no sign of any shininess whatsoever. Just to be sure, go over the entire area once more, this time using a circular motion. Clean the area with a lint free cloth and denatured alcohol. To prevent contamination of the surface avoid touching it with your hands.

Cracks... Avoid jeopardizing or cracking the canopy at all costs. If the unthinkable happens and a crack appears it may sometimes be repaired using a solvent adhesive such as Plasti-Fix or Weld-On 3. Stop-drilling the crack is typically required to keep it from running.

CLEANING AND USE OF LIQUIDS

CAUTION: DO NOT use Loctite, aromatic solvents, acetone, benzene, ethyl acetate, carbon tetrachloride, lighter fluid, lacquer thinners, gasoline, toluene, window sprays, concentrated alcohols, ketones, scouring compounds, ammonia, or 409 cleaner on or around acrylic or Lexan canopy materials.

The adhesive used on some brands of electrical tape may be incompatible with acrylic or Lexan. Test the tape on a scrap of material before use. In all cases do not leave the tape on the canopy for extended periods of time (more than two days).

For general cleaning use Dawn dishwashing liquid or equivalent and water followed by a clear water rinse. To prevent water spots, blow-dry with compressed air or wipe dry with soft cotton flannel. Plexus, Sprayaway #848 Industrial Plastic Cleaner, or All Clear can also be used for day to day cleaning. Grease, oil, tape residue, etc. may best be removed with mineral spirits, refined kerosene, white gasoline, naphtha, or isopropyl alcohol. Wash approved solvents off the canopy with Dawn dishwashing liquid and water. It is best to avoid using products on your canopy that are not specifically formulated for acrylics such as Rain-X or Lemon Pledge.

SCRATCH REMOVAL

Small scratches can be buffed out with Meguiar's Mirror Glaze Plastic Cleaner #17. For deep scratch removal, use Scratch Off , Micro Mesh, or 3M Window Repair kits. Avoid removing scratches in critical areas where clear visibility is important, as the process will usually result in some degree of optical distortion.

CANOPY PROTECTION AND VENTILATION

If the aircraft is tied down outdoors and subject to weather elements for any length of time, then the use of an aircraft canopy cover is highly recommended. The cover will protect canopies and windows from abrasive dust, dirt, and sand kicked up by wind or prop wash. Before purchasing, verify that the canopy cover is NOT waterproof as the trapped moisture and heat from the sun can be deleterious. Acrylic subjected to this treatment over a period of time may turn slightly milky and eventually craze.

Keep your canopy ventilated or covered when your aircraft is parked in the hot sun. Cabin temperatures can easily reach 150-200 degrees F even on a mild day. The acrylic can generally take these temperature conditions multiple times without any apparent adverse effect. It is the cumulative affect that will cause shortened service life of your canopy. The use of a Van's Aircraft Canopy Cover will significantly reduce the internal temperatures inside your aircraft to just a few degrees above outside ambient temperatures. Additionally it will also protect your expensive avionics from heat and your upholstery/seat belt harnesses from harmful UV rays.

In winter conditions ensure that the cabin and canopy are warmed adequately prior to flight whenever possible. A heat lamp or small, low output ceramic space heater can raise the cabin temperature to warm the acrylic, keeping it free from ice or snow. It will also be less prone to cracking.



5.20 NUT AND BOLT TORQUES

The importance of correct torque application cannot be overemphasized. Under-torque can result in unnecessary wear of nuts and bolts, as well as the parts they secure. Over-torque can cause failure of a bolt or nut from over-stressing the threaded areas. Uneven or additional loads that are applied to the assembly may result in wear or premature failure. The following are a few simple, but important procedures, that should be followed to ensure that correct torque is applied.

NOTE: Insure that the torque to be applied is for the size of the bolt shank not the wrench size.

Use the standard torque table provided as a guide for tightening nuts, bolts and screws whenever specific torque values are not provided in the builders manual. These values are for clean and dry threads. Note that on the smaller bolts the torque is quite low and is in inch pounds. Do not use a foot pound torque wrench on these bolts, but instead use a torque wrench calibrated in inch pounds. The propeller manufacturer and the engine manufacturer have specific torque requirements for their equipment. Consult the appropriate manual for that information. Apply a smooth, even pull when applying torque. When using the 1/4 in. drive snap-over type torque wrench we recommend practicing with it off the aircraft first until you get the feel of the particular tool's snap-over feature since it can be rather light depending on the size of the fastener.

Apply the torque to the nut and not the bolt whenever possible. This will minimize rotation of the bolt in the hole and reduce wear. When the bolt is rotated for final torque the chart values must be modified. When applying torque to a bolt be sure to have a washer under the bolt head and lubricate the bolt shank. Add to the overall torque value the torque required to overcome the friction associated with turning the shank of the bolt within the assembly.

When tightening fasteners with self-locking nuts the chart values must be modified. Due to the friction of the locking device noticeable torque is required just to turn the nut onto the threads and does nothing to actually tighten the parts together and stretch the bolt (clamp load). This is called friction drag (or prevailing) torque. The friction drag torque must be determined and then added to the standard torque from the table. Run the nut down to where it nearly contacts the washer or bearing surface and check the friction drag torque required to turn the nut. (At least one thread should protrude from the nut). Add the friction drag torque to the standard torque. This sum is referred to as the final (or total) torque, which should register on the indicator or setting for a snap-over type torque wrench.

As an example illustrating the importance of determining the friction drag torque consider a new AN3 bolt and MS21042-3 all-metal lock nut. Our tests showed an average friction drag torque of 14 in-lbs (your results may vary). The standard torque for this nut/bolt combination from the table below is 28 in-lbs. This results in a final torque setting on our wrench of 14 plus 28 or 42 in-lbs. Though we exceeded the 28 in-lb value listed in the table by using a final torque of 42 in-lbs we are still well within the capability of the nut. (Incidentally this nut must meet a maximum torque test value of 60 in-lbs per the military standard spec sheet.) Now what if we completely ignore the friction drag torque and set our wrench to just 28 in-lbs? Recall that it requires about 14 in-lbs (friction drag torque) just to turn the nut. We subtract 14 from 28 and arrive at only 14 in-lbs of torque (torque being the measurement of friction, not tension) applied to induce preload (clamp load) in the bolt. Not a satisfactory result.

(Portions of this information has been adapted from AC 43.13-1B Section 7-40.)

AN Bolt Size	Bolt Size- Threads Per Inch	Standard Nuts AN310, AN315, AN365		Self Locking Nut MS21042-3, MS21042-4	
		INCH POUNDS	FOOT POUNDS	INCH POUNDS	FOOT POUNDS
AN3	#10-32	20-25	1.6-2.0	28	2.3
AN4	1/4-28	50-70	4.2-5.8	85	7.0
AN5	5/16-24	100-140	8.3-11.6		
AN6	3/8-24	160-190	13.3-15.8		
AN7	7/16-20	450-500	37.5-41.7		
AN8	1/2-20	480-690	40.0-57.5		
AN9	9/16-18	800-1000	66.6-83.3		
AN10	5/8-18	1100-1500	91.6-125.0		
MS21042-3	10-32	28	2.3		
MS21042-4	1/4-28	85	7.0		

FASTENERS AS PIVOT POINTS

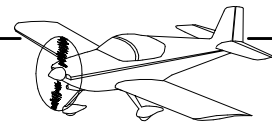
In specific cases, bolts are intended to be used as axis of rotation. The most common example is the attachment of control system cables. Here, it is intended that the cable end fitting pivot on the bolt. In these instances, the nut must not be torqued to the standard torque value. Instead a castellated nut, safetied with a cotter pin, is used. Finger-tighten the nut, then install the cotter pin. The cable end fitting must pivot freely when the installation is complete.

MS NUTS

A common rule of thumb for evaluating whether an installed bolt is the proper length has always been that up to three thick washers are allowed (if more than three are needed the next shorter bolt should be used), and that at least one but no more than three full threads of the fastener are to be showing beyond the nut. This rule of thumb works for the AN365 nuts that have been commonly used on RVs for years.

Some of the newer RV kits use the all metal MS21042 self locking nut. The long standing rule of thumb will not work for these nuts because they are shorter in height than the AN365 nut. For these nuts, modify the rule of thumb to "at least three, but not more than five threads showing." This rule of thumb will still allow for meeting the 'maximum use of three washers' rule.

You may have to educate any technical councilors or airworthiness inspectors that perform inspections on your project. Some inspectors are not familiar with these smaller sized nuts.



5.21 ELECTRICAL

ELECTRICITY

There are three primary units of measure or terms to know to successfully wire the aircraft: voltage, current and power. The battery we will be dealing with is known as a 12V battery. Batteries in good charge will have a terminal voltage between approximately 12.8 and 13 volts. When a battery is installed in an airframe and the alternator or generator is operating, the system voltage will be 14 to 14.5 volts. The second term is current which is measured in units of amps (A). Current is a value representing the flow of electrons through a wire. An analogy would be a measurement of the flow of fuel to the engine in gallons/hour. The amount of current (amps) flowing in a circuit will determine the size of the circuit breaker (or fuse), the type of switch to use and the size of wire to use. The last term we must understand is power, more specifically the power being consumed by a circuit, which is measured in units of Watts (W). Items such as lights are typically rated in watts.

WIRING

Stranded wire is preferred over a solid conductor. Solid conductor wire (a single strand of wire) is more susceptible to breakage from the normal vibrations of an aircraft. Automotive type wire can be used in most applications. The only exception would be where shielded wire is desired.

Wire should be supported such that it does not sag or swing freely. When passing through a bulkhead, use a grommet or support the wire in the center of the hole with clamps to prevent chaffing which could result in an in-flight electrical short. Bundling wires together is acceptable, except when a noisy wire is included with a sensitive circuit. An example of this would be including the transponder antenna lead or a strobe power lead in the same bundle with the mike wire or headset leads. The impulses created by either the transponder or the strobe could be picked up by the audio wiring.

WARNING: Antennas must be hooked up before turning on the transponder or radio or damage may result. Refer to the transponder, radio, and antenna manual/installation instructions for more information.

Wire colors are called out in the building plans as needed. Wire call outs are followed by their color in brackets. (WIRE COLOR/STRIPE COLOR). Colors are abbreviated as follows: BLK = BLACK, BLU = BLUE, BRN = BROWN, GRN = GREEN, GRY = GRAY, ORN = ORANGE, PRP = PURPLE OR VIOLET, RED = RED, WHT = WHITE, YEL = YELLOW. Harnesses are supplied with multi-colored wire or white wire with a label.

D-SUBS

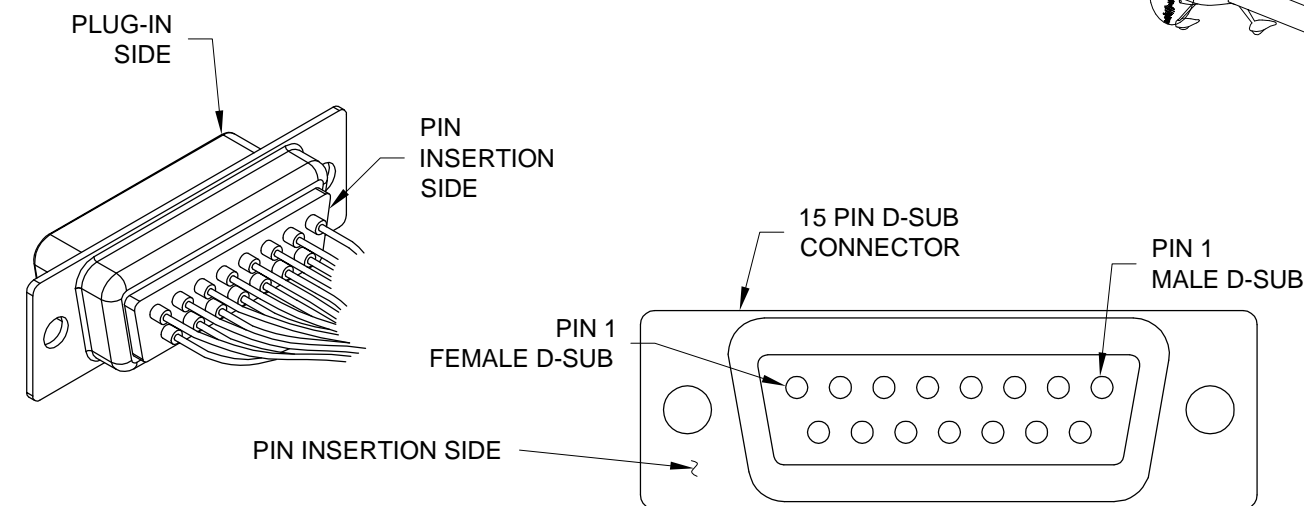


FIGURE 1: INSERTING D-SUB PINS

CRIMPING D-SUB PINS

Connect all 20-24 AWG wires to D-Subs using ES-SA-1017 machined sockets or ES-SA-1018 machined pins. It is permissible to strip 18 AWG wire to fit ES-SA-1017 sockets or ES-SA-1018 pins. All crimps should be made with the recommended tool (tool spec. meets MIL-DTL-22520, Type I tool producing an indent termination.) See Table 1, Page 05-24 for recommended tools.

Step 1: Strip wire per Page 05-24, Table 1.

Step 2: Insert the stripped wire into the barrel end of the pin or socket connector as shown in Figure 2. The wire must be visible through the witness hole in the pin or socket.

Step 3: Follow the tool manufacturer's directions when operating the crimp tool.

Step 4: Test the crimp by gently pulling on the pin or socket and the wire.

REPAIRING D-SUB PINS

If the proper crimping tool is unavailable, machined d-sub pins and sockets may be soldered on. If unfamiliar with soldering it may be prudent to practice this procedure on a sample wire before repairing the flight article wire.

Step 1: Strip wire back per the dimension in Figure 2.

Step 2: Tin the end of the stripped wire by heating up the wire as it exits the insulation while holding solder against the tip of the wire. When the solder wicks into the strands of the stripped wire remove the heat and solder. **It is very important to not let the solder wick beyond the end of the exposed wire under the insulation. This will make the wire brittle, fatigue and break where it exits the back of the pin.**

Step 3: Slide the tinned portion of the wire fully into the pin or socket. Use a soldering iron to heat the barrel of the pin or socket while inserting solder wire into the witness hole (This will require a solder wire of a small diameter). Melt solder into the witness hole, then remove the heat and solder. Be careful not to get excess solder on the barrel of the pin or socket

Step 4: Check that the wire is properly soldered to the pin by gently pulling on the pin or socket and the wire.

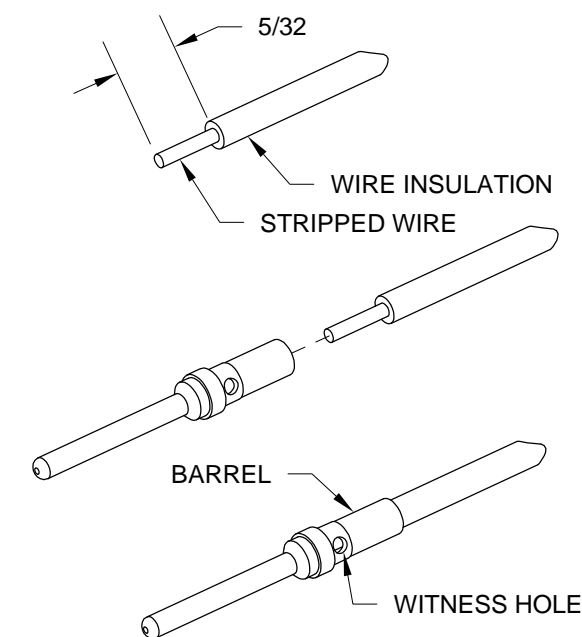


FIGURE 2: SOLDER WIRE TO PIN



5.21 ELECTRICAL (continued)

BACKSHELL ASSEMBLY

There are a number of connections which make use of d-sub assemblies sheathed with a backshell. There are a variety of backshell styles, two of which are discussed here and illustrated in Figure 1. For both styles of backshell, ensure that the wires are properly installed and heat shrink tubing is installed to secure the wire bundle.

The **two piece backshell** contains two metal strain reliefs. These are secured around the wire bundle with two screws. One screw is installed from the top, and one from the bottom as shown in Figure 1. Position the strain reliefs so that they will fit the recess in the backshell halves.

Install the d-sub assembly in the bottom half of the backshell. Loosely attach the top and bottom halves of the backshell with the hardware as shown in Figure 1. Note that one screw is installed from above, and one is installed from below. Pry the backshell halves apart to insert the jack screws through the aft side of the assembled backshell halves. The jack screw shoulder will be captured by the top and bottom backshell halves and extend through the corresponding hole in the d-sub assembly. With the jack screws and saddle washers captured, tighten the top and bottom screws to complete the assembly. See Figure 1.

The **clamshell style backshell** has a plastic strain relief that nests in the bottom half of the clamshell and the wire bundle is secured with a metal strain relief on the top as shown in Figure 1. Jack screws snap into molded receptacles in the bottom half of the clamshell and extend through the holes in the d-sub assembly. To complete assembly the top half of the clamshell is closed and snapped into place with the molded posts and integrated side latch.

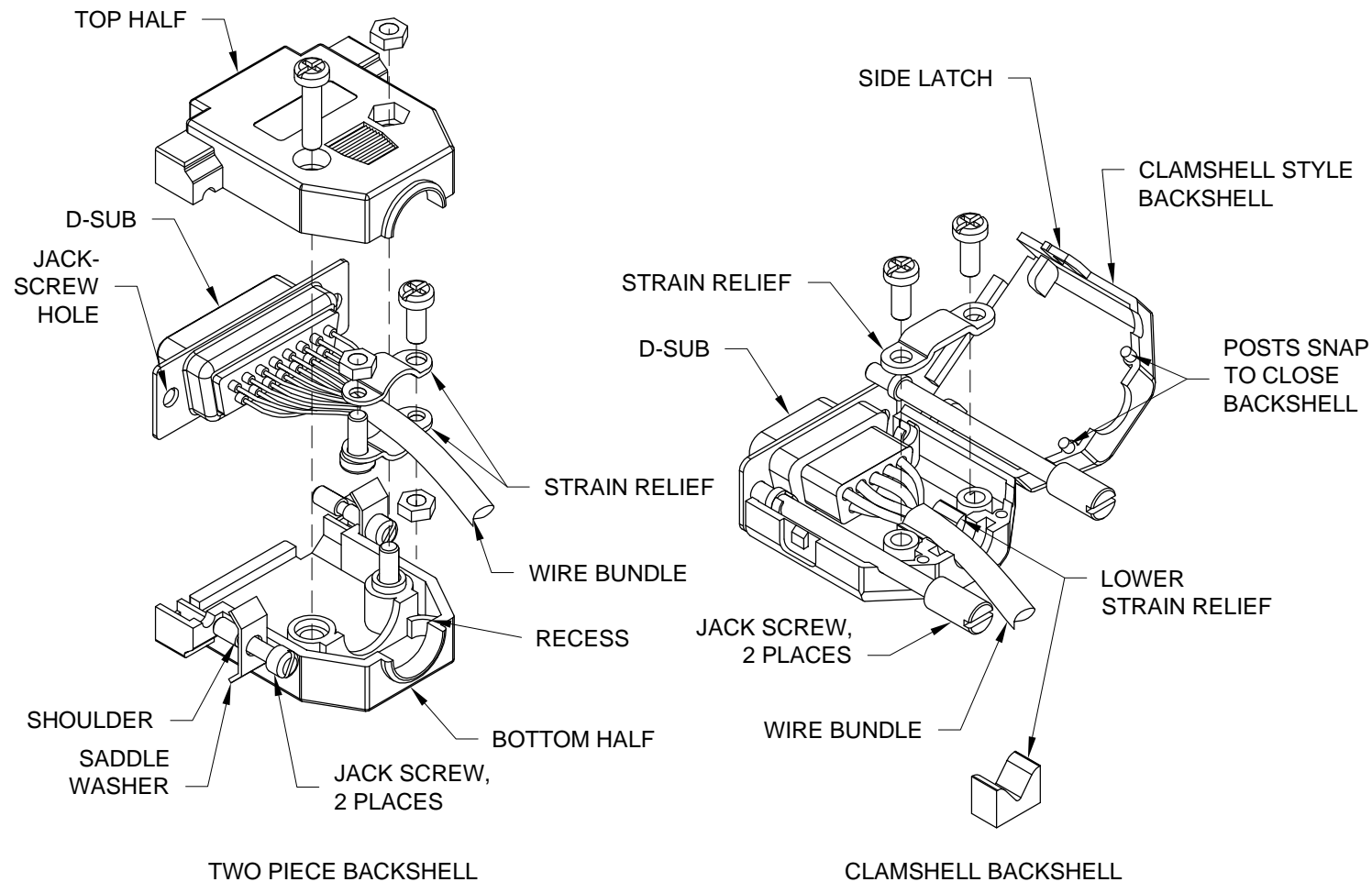


FIGURE 1: BACKSHELL ASSEMBLY

SHIELDED WIRES

Some wires included in the kit are shielded with braided wire surrounding the main conductor wire(s). Unless otherwise stated all shields are connected to ground at the d-sub connector that the wire is coming from. The shield on the device end of the wire should not be connected to ground.

When stripping the inner conductor wire(s) remove and discard the shield as shown in Figure 2. Cover the exposed shield with heat shrink. This will ensure that when the conductor wire is crimped to a connector there will be no possible electrical connection between the connector and the shield or between the shield and the fuselage structure.

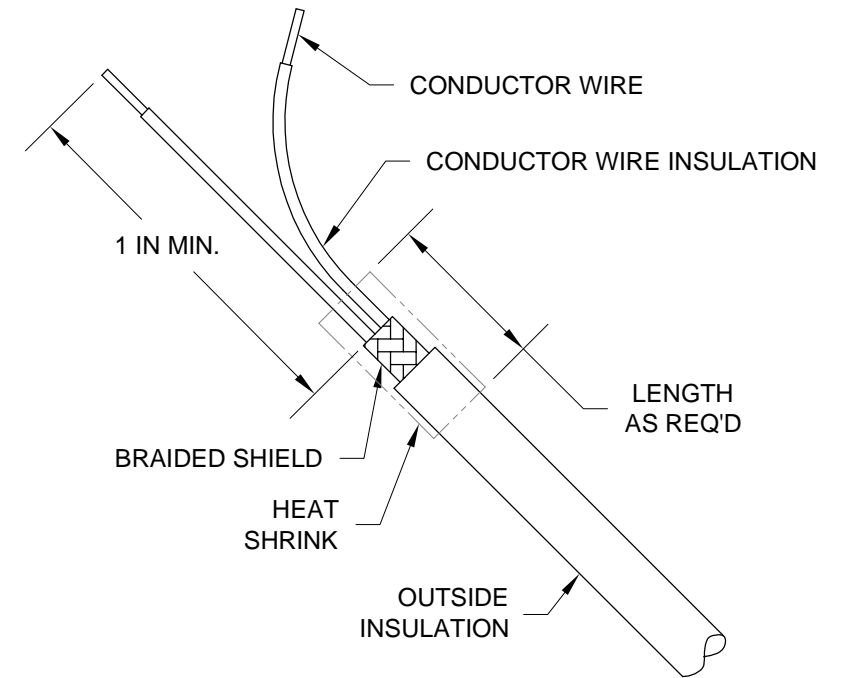


FIGURE 2: STRIPPING SHIELDED WIRES

MOLEX CONNECTORS

NOTE: When installing wire pins into Micro-Fit connectors, the pin will only fully insert and lock in one position. If it fails to insert, rotate 90 degrees and try again. Note the orientation when it properly inserts and position all subsequent pins the same. This also applies to sockets. Lightly pull test each wire after insertion to verify it has hooked into the connector body. If inserted incorrectly Micro-Fit pins and sockets may be removed by using a Micro-Fit Extractor.

When installing Molex sockets into Molex receptacles, the socket will only fully insert and lock in one orientation. To ensure proper orientation, always face the socket seam, which appears along its length, toward the receptacle's retaining lever as shown in Figure 3. This also applies to the pins.

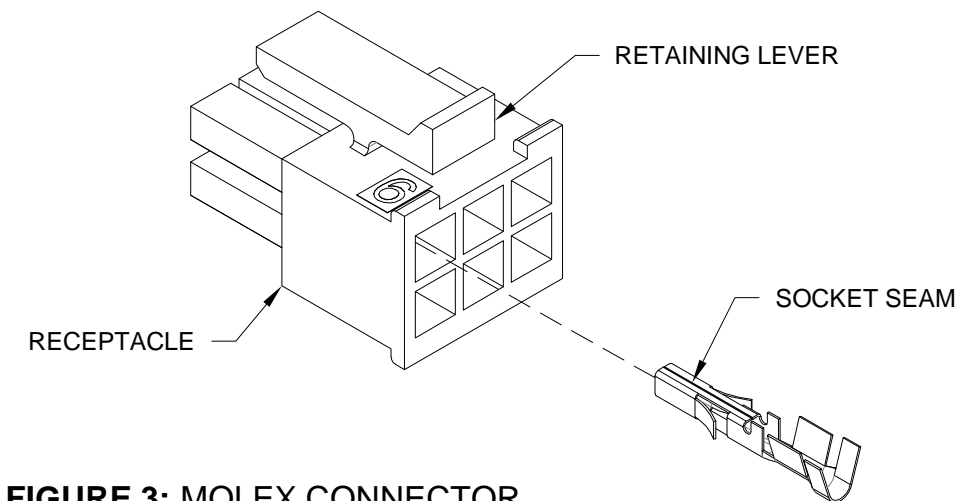
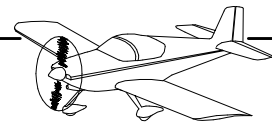


FIGURE 3: MOLEX CONNECTOR



5.21 ELECTRICAL (continued)

ELECTRICAL CONNECTIONS

NOTE: Terminals should be crimped, but not necessarily soldered. If a termination is soldered, the wire should be supported near the solder joint to ensure there is no movement of the wire at the solder joint. The point where the wire goes into the solder joint is subject to breakage if the wire is allowed to move freely (i.e. normal vibrations and flexing).

CLOSED BARREL TERMINALS

Closed Barrel Terminals include Ring Terminals, Spade Terminals, and Butt Splices as shown in Figure 1. While the exposed ends may be of a different configuration, the common feature of a closed barrel terminal is a precision-formed metal wire barrel and a copper sleeve encased in insulating material made of nylon, polyvinyl chloride (PVC) or polyvinyl flouride (PVF²). The insulation is color coded to correspond with a specific wire size or wire size range.

These terminals are crimped in two places: first where the wire is stripped and second where the wire insulation fits inside the terminal. The first crimp retains the wire and provides a good electrical connection between the wire conductors and the terminal. The second crimp supports the end of the insulation thus protecting the wire conductors at the end of the insulation where they would otherwise be likely to break.

The barrel comes in various sizes. The most common will be for wire sizes (AWG) 22-16, 16-14, 12-10, 8 for the alternator and the 2 gauge battery wires. Smaller barrels will accommodate more than one wire size, whereas the larger barrels are designed specifically for one wire size. Sometimes the barrel has insulation, which is the terminal type used in most of our applications. The larger terminals for 2 gauge wires are usually not insulated.

While some barrels are continuous or braised, the industrial quality barrel will be a folded or rolled barrel. When crimping it is important to note where the seam is to ensure that the crimp will not cause the barrel to spread open.

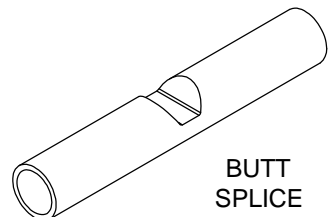
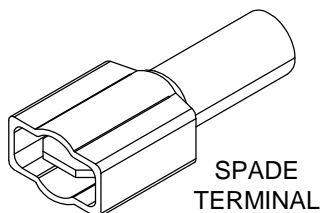
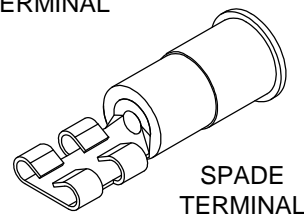
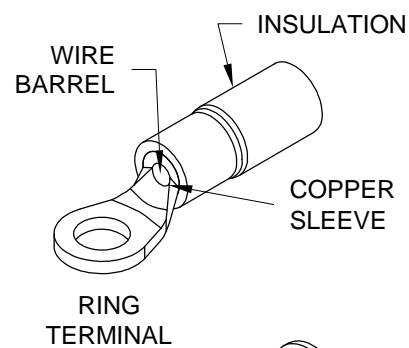


FIGURE 1:
TYPES OF CLOSED BARREL TERMINALS

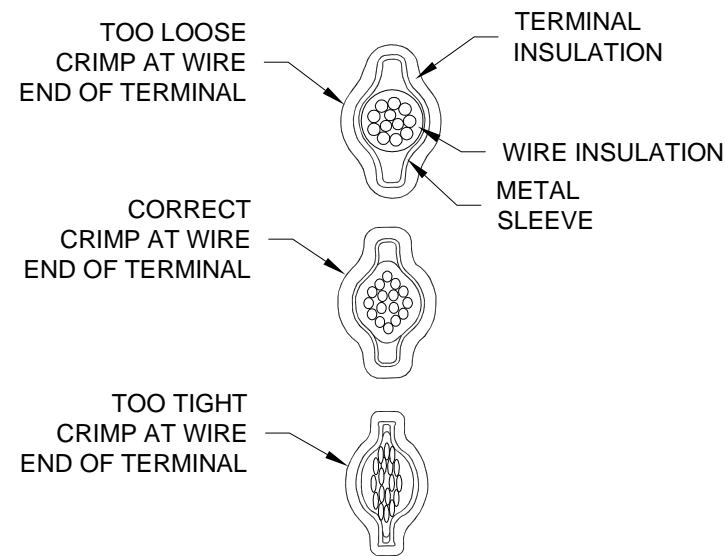


FIGURE 3:
CORRECT & INCORRECT EXAMPLES

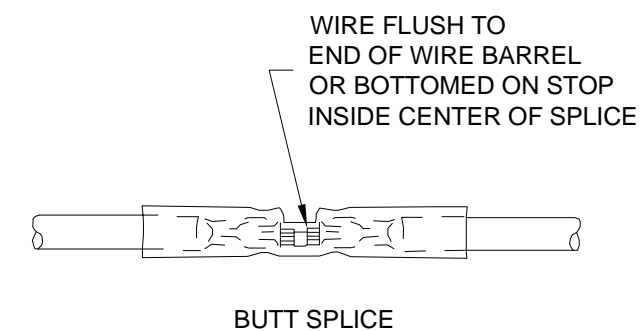
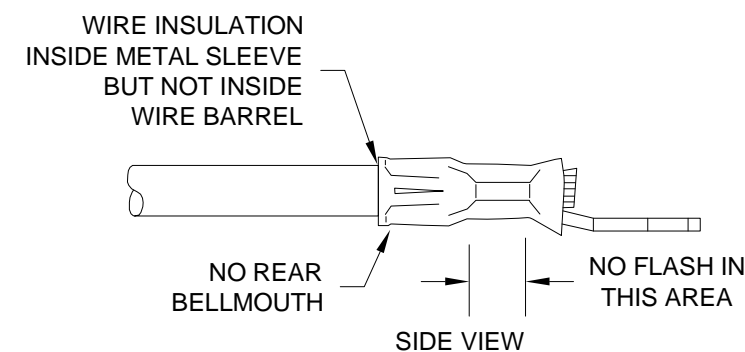
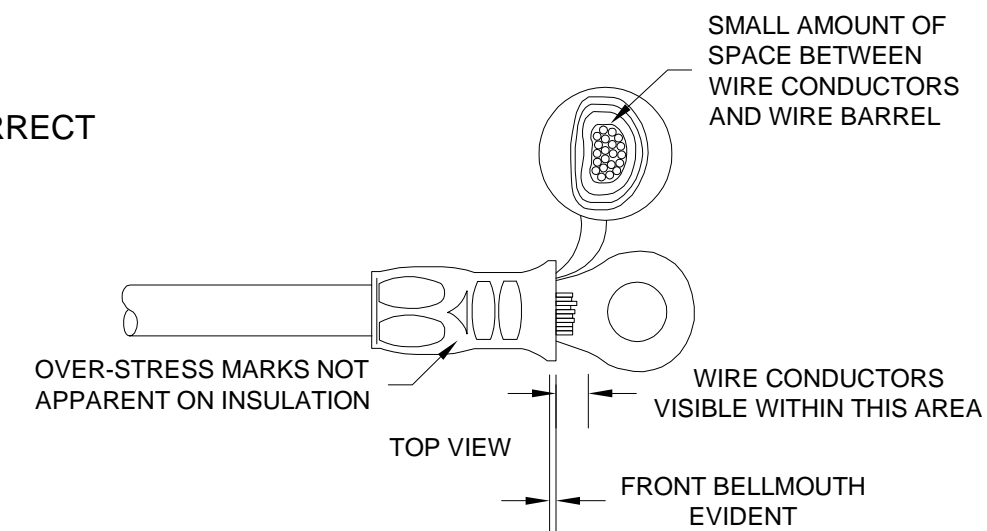


FIGURE 4: CRIMPING OF CLOSED BARREL TERMINALS

CRIMPING

There are several types of crimping pliers on the market. Most of them will flatten the barrel when the crimp is made (Figure 2 view "B") from its original round shape (view "A"), while others will form a crescent shape when crimped (view "C"). It is important when crimping to not squeeze the crimp so hard that the wire strands are broken or cut by the squeezed barrel, yet hard enough that the compressed barrel will securely hold the wire strands.

Most quality crimp style connectors require two crimping operations. The first crimps the conductor portion of the wire within the connector, and the second crimp clamps the insulation portion of the wire, providing a strain relief. If the wire flexes or vibrates, the movement is not occurring just on the wire strands.

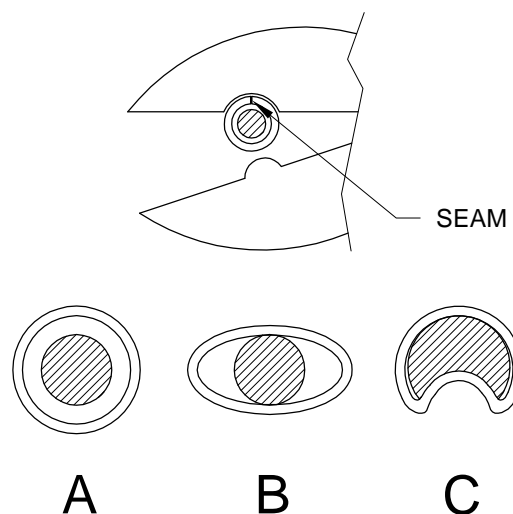
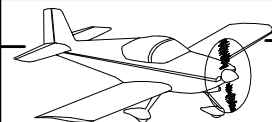


FIGURE 2: CRIMPING

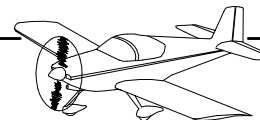


5.21 ELECTRICAL (continued)

Strip the wire according to the WIRE STRIP LENGTH found in Table 1, then use the crimp tool.

TERMINAL INSTALLATION TABLE				
PART NUMBER	NOMENCLATURE	WIRE STRIP LENGTH	RECOMMENDED CRIMPING TOOL	TOOL USE NOTES
ES-00003	MOLEX PIN .093	.130 -.150	BCT-1	
ES-00004	MOLEX SOCKET .093	.130 -.150	BCT-1	
ES-00005	MOLEX PIN .093	.130 -.150	BCT-1	
ES-00006	MOLEX SOCKET .093	.130 -.150	BCT-1	
ES-00014	MOLEX PIN .093	.156 -.218	BCT-1	
ES-00015	MOLEX SOCKET .093	.156 -.218	BCT-1	
ES-00046	MOLEX MICRO-FIT SOCKET	.100 -.115	BCT-1	FOR 26 AWG WIRE DOUBLE STRIP LENGTH & FOLD OVER
ES-00047	MOLEX MICRO-FIT PIN	.100 -.115	BCT-1	FOR 26 AWG WIRE DOUBLE STRIP LENGTH & FOLD OVER
ES-00079	FLOATING CONNECTOR PIN	.150	BCT-1	
ES-00080	FLOATING CONNECTOR PIN	.150	BCT-1	
ES-31890	RING TERMINAL, #8	.203 -.234	TH-450	
ES-31906	RING TERMINAL, 1/4	.203 -.234	TH-450	
ES-320559	BUTT SPLICE	.250 -.281	TH-450	
ES-320562	BUTT SPLICE	.250 -.281	TH-450	
ES-320565	RING TERMINAL, #8	.203 -.234	TH-450	
ES-320571	RING TERMINAL, 1/4	.203 -.234	TH-450	
ES-320619	RING TERMINAL, #6	.203 -.234	TH-450	
ES-321045	RING TERMINAL, 1/4	.203 -.234	TH-450	
ES-323990	RING TERMINAL, #10	.188 -.219	TH-450	
ES-324043	RING TERMINAL, #10	.313 -.344	TH-450	
ES-324044	RING TERMINAL, 5/16	.313 -.344	TH-450	
ES-324082	RING TERMINAL, 1/4	.313 -.344	TH-450	
ES-36152	RING TERMINAL, #6	.203 -.234	TH-450	
ES-36154	RING TERMINAL, #10	.203 -.234	TH-450	
ES-421-0107	SPADE TERMINAL	.203 -.234	TH-450	
ES-421-0108	SPADE TERMINAL	.203 -.234	TH-450	
ES-640903-2	SPADE TERMINAL	.203 -.234	TH-450	
ES DV18-188-M	SPADE TERMINAL	.203 -.234	TH-450	
ES SA-1017	D-SUB SOCKET	.188 -.208	ECL 300-015	FOR 26 AWG WIRE DOUBLE STRIP LENGTH & FOLD OVER
ES SA-1018	D-SUB PIN	.188 -.208	ECL 300-015	FOR 26 AWG WIRE DOUBLE STRIP LENGTH & FOLD OVER

TABLE 1: WIRE TERMINAL INSTALLATION INFORMATION



5.21 ELECTRICAL (continued)

OPEN BARREL TERMINALS

The following text has been reproduced from "The AeroElectric Connection" <http://aeroelectric.com/articles/matenlok/matenlok.html>
Special thanks to Bob Nuckolls for allowing us to reproduce this information.

Figure 1 is a closeup of the business end of our Open Barrel Terminal Crimp Tool. Note that pockets "C", "D" and "E" have "butt-cheeks" formed into the upper surface. These pockets cause the end of wire grip wings to curl over and dive into the approximate center of the wire strands. Pockets "A" and "B" have a smooth, circular shape used to shape the terminal's insulation-grips into a "bear hug."

Figure 2 shows a typical nylon connector housing and a strip of open barrel pins. This particular connector is a Waldom/Molex product purchased in a blister-pak from Radio Shack. The techniques described here are typical for all connectors of this genre.

If you wish to mount the connector in a hole, the tabs visible at the rear of the connector housing can be folded flat against the side of the connector. Barbs molded into the wings will slip through the appropriate sized rectangular hole and hold the housing captive in the hole. Check the original manufacturer's data for recommended hole dimensions.

Pins supplied in strips are intended for application by automatic machine. The pins come in reels of perhaps 10,000 and feed into the side of an application machine like a belt of cartridges into a machine gun. For our use, we need to cut individual pins apart similar to what you see here in Figure 3. Note that part of the material that joins adjacent pins is left in place. It's too long in this view and will be snipped off again later.

FIGURE 1



OBC-1 CRIMP TOOL FOR OPEN BARREL TERMINALS

THESE TABS USED TO "MOUNT" CONNECTOR IN HOLE

FIGURE 2

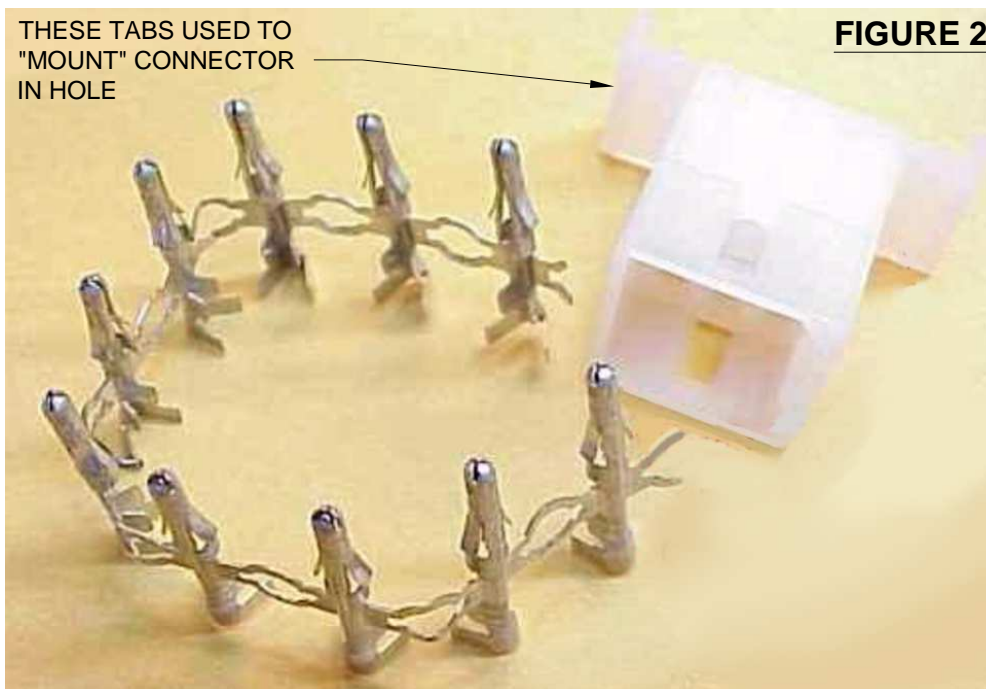


FIGURE 3



Strip the wire about 3/32". Note that I've shortened the insulation grip wings on this pin. These connectors are designed for automotive applications where wiring insulation is MUCH larger in diameter than for the same AWG size in aircraft wire. Left full length as supplied, it's difficult if not impossible to get a proper "bear hug" on the wire's insulation. See Figure 4.

Note shortened wire grip "wings". I've also shortened the stop tabs but they will prove to be too long.

FIGURE 4



If left in as-supplied shape, the wire-grip and insulation-grip wings tend to rotate the pin in the tool's dies as they close. This can result in a poorly shaped crimp or even broken wings. Use a pair of pliers to bend the wings into a "U" shape with sides parallel or even tilted inward toward each other slightly. See Figure 5.

FIGURE 5



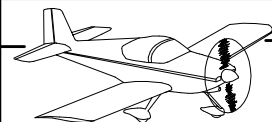
Now comes the fun part. Grip the pin loosely in pocket "D" with the ends of the wire grip wings pointing toward the pocket's "butt cheeks". Insert the stripped end of the wire so that exposed strands are inside the crimp area. Close the tool while being watchful of dreaded "pin-spin". If things go as they should, ends of wire grip wings will do a 180 degree turn and dive back into the center of the strands from both sides. You'll want to squeeze the tool with as much force as you can with one hand. When you've got a nice LOOKING crimp, put a 5-8 pound pull on the wire to make sure it doesn't pull out easily from under the wire grip. If it does, you need to squeeze harder next time.

Use tool pocket "A" to form the insulation-grip wings down onto the wire's insulation. You'll have to rotate the pin in the tool so that the ends of the wings are pushed into the circular bottom of the pocket. As the ends of insulation-grip wings collide in the bottom of the pocket - don't compress the tool any further. Take the pin out and use the end pincers of the tool to deflect the end of one insulation grip down against the insulation. Return the pin to pocket "A" and rotate the pin in the pocket as you form the insulation-grip wings down smoothly around the wire. The goal here is very different from the electrical connection. The conductor strands need to be held very tightly while the insulation gets a only snug "bear-hug" as shown here. If you look at similar pins installed on PVC insulated automotive wire, the fabricator may have turned the insulation-grip wings into the insulation not unlike the wire-grip. I DO NOT RECOMMEND this on the aircraft wire - the insulation is too thin. For airplanes we want a simple, snug support of the wire behind the wire-grip without penetrating the insulation.

Note also in Figure 6 how short the stop tabs are. Trim with caution as you learn how to deal with each style and size of pin. Cut the tabs off too short and the pin will not be properly retained when installed. If the tabs are too long, the pin will simply resist insertion into the back of the connector housing.

FIGURE 6





5.21 ELECTRICAL (continued)

OPEN BARREL TERMINALS (continued)

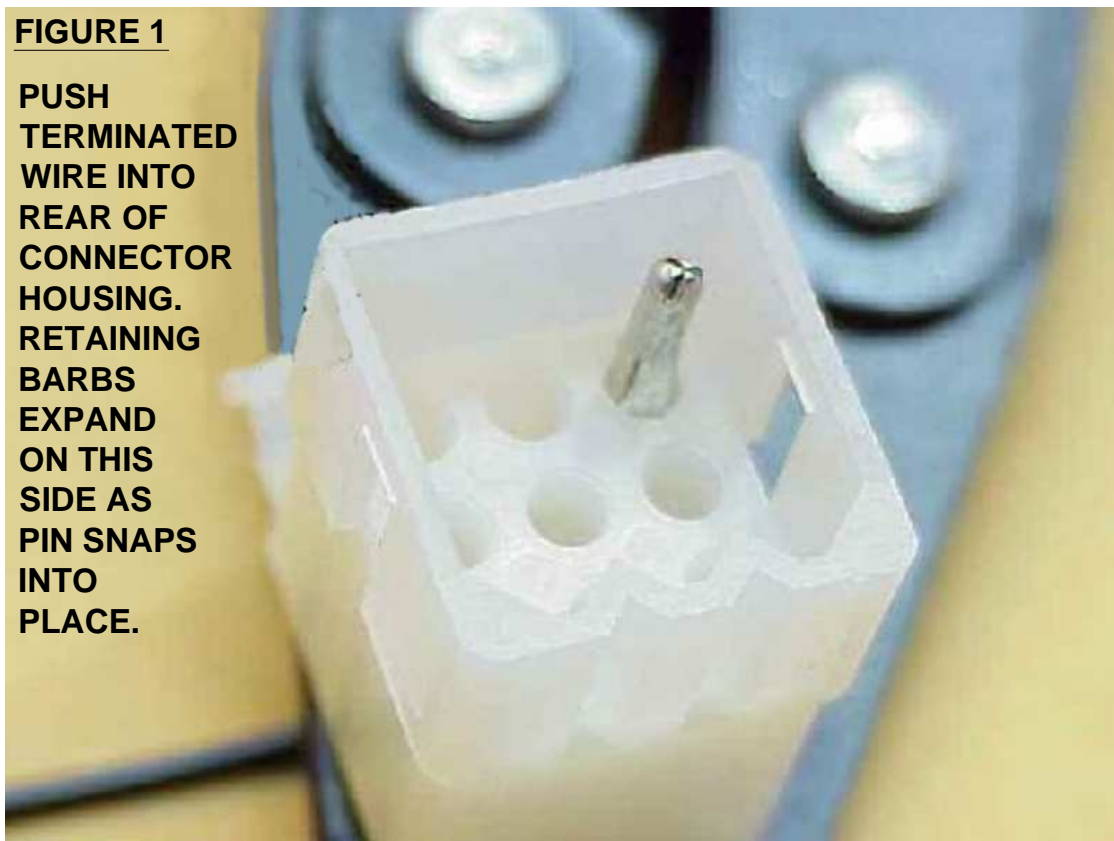
Now you can install the pin into the connector's housing. In Figure 1 you can see the barbs that snap out to keep the pin from being pulled backwards through the hole. The stop tabs will bottom out in the hole from behind to keep the pin from coming on through.

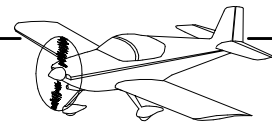
The technique I've just described is typical of the AMP Mate-n-Lock and the larger (.093" pins) sized Waldom/Molex connectors. The smaller Waldom/Molex connectors (.063" pins) use pockets "E" for wire grip and "B" for insulation grip. Wires of up to 14AWG and carrying up to 10 Amps may be routed through this style of connector. The wire I illustrated here is 20AWG. Use pocket "C" to crimp 16 and 14AWG wire. 22AWG wire is somewhat dicey in .093" pins. Waldom/Molex connectors also come in a smaller size having a nominal pin diameter of .063". Use pockets "E" and "B" to install the smaller pins like D-subminiature pins found on many instruments and avionics products.

Some connectors may be supplied with loose pins. In this case, you will not have to trim the stop tabs - they will be the proper length as supplied. You may still have to shorten either wire grip or insulation grip wings to work well with your wire of choice. It's always a good idea to experiment with extra pins on scraps of wire to see what it takes to achieve the smooth and tight crimp/grip shown on Page 05-23, Figure 6. Each manufacturer of these connectors offers an extraction tool that will let you remove a pin without damage for re-use in the same or a different location on the connector. Female pins are installed the same way.

FIGURE 1

**PUSH
TERMINATED
WIRE INTO
REAR OF
CONNECTOR
HOUSING.
RETAINING
BARBS
EXPAND
ON THIS
SIDE AS
PIN SNAPS
INTO
PLACE.**





5.21 ELECTRICAL (continued)

ELECTRICAL TROUBLESHOOTING

NOTE: Van's Aircraft has tailored each avionics component for the combination of aircraft and avionics by supplying each component with a specific set of default presets. Although not supplied in the kit a list of these presets are available upon request.

WARNING: Never run an electrical system using power from a battery charger only. Always have a battery connected to the system. Always connect the battery charger on the battery side of the master relay so that if the relay is turned off the charger will not be left as the only device providing power to the system. Battery chargers alone may produce voltage levels that will damage components connected to the electrical system!

Control Module

CAUTION: The potentiometers used to control audio levels and trim speed etc. can easily be damaged by excessive force. Use only the supplied adjustment screwdriver tool (TOOL-00000) and use only light pressure to keep it engaged on the screw head.

Besides the control of the pitch trim, audio mixer, dimmer (flap, landing light pulse and roll trim as well for non-RV-12 installations) the control module makes connections between different avionics systems, sensors and electrical devices in the aircraft. For these circuits the control module is nothing more than a connecting wire between an input and output pin taking the place of many complex wiring harnesses. When troubleshooting a problem in the electrical system it is tempting to assume that the problem lies inside the control module or "unknown black box". Although it is possible that the control module could have a defect there is a very low probability since each unit is tested before shipment. Instead, in most instances the control module should be treated like a wire. Problems occurring with wiring rarely occur in the wire itself but more often at the connections between the wires or within the devices being connected. Some connections on the control module besides the circuits stated above do contain discrete components such as diodes and resistors. Such components are shown on the overall electrical schematic available from the downloads page of the Vans Aircraft web site.

Continuity Test

CAUTION: Checking the wrong pins is a common error made by even the professionals. Triple check you are checking for continuity on the correct pins.

One of the most useful troubleshooting steps is the continuity test. Many multi-meters today have a setting for performing a continuity test. Touch the leads coming from the tester to each end of a wire and if there is an electrical connection then the multimeter will generate a tone indicating a good electrical connection. If your multimeter did not include this setting use the resistance setting. If the resistance is a very large number in the Mega Ohm range then there is not continuity. If the resistance is zero or nearly zero then continuity exists.

If for example an EFIS is not receiving data from another device. Test for a connection between the end of the wire that connects to the EFIS and the end of the wire that connects to the device. This will by default also test the connection through the control module as well. If there is continuity the wiring is not the problem (hopefully you have already double checked for a proper setup within the menus of the EFIS and the device). If there is not continuity, then each portion of the wiring harness for that circuit path will need to be checked separately for continuity to find the problem (the control module itself, the harness from the control module to the device, the harness from the control module to the EFIS).

Audio

Basic Checks:

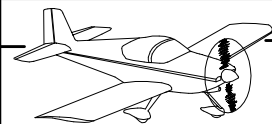
Always check that your headset is plugged in properly. Try a different headset or even a different headset type. Try one headset at a time or the same headset in different positions. Check that ANR headsets have fresh batteries.

Van's Aircraft audio systems are stereo not mono. *Double check that all headsets are set to stereo mode.* Setting some headsets to mono will short the left and right channels together resulting in no audio.

Check that the radio and transponder (if applicable) are properly (fully) inserted into their trays.



FIGURE 1: TYPICAL HEADSET SETTINGS



5.21 ELECTRICAL (continued)

Problem Isolation: There are several quick easy steps to isolate an audio noise problem. Try turning the intercom volume knob. If the problem is controlled by the intercom volume the problem is the intercom itself, wiring from the intercom to the headset jacks, the headset jacks or the headset. As stated above try different headsets in different jacks. Try turning off each device individually (EFIS, COM, transponder, ADS-B, GPS, unplug an aux music device such as an iPhone and any connecting cable, a car charger plugged into the 12V power outlet, etc...) to help isolate the source of the problem. Some circuits may only be controlled by removing a fuse. Remember to shut the master off before removing a fuse. When calling for tech help first isolate the problem, this will save time.

Problem: The Audio levels are different using the same headset in the pilot and co-pilot positions.

Solution: If one side is different than the other the problem may be in the headset jacks. Inspect the wiring below the headset jack that is not receiving/transmitting properly to be sure that no wires are shorted out. Move the wires to check for a loose connection. If you can hear or transmit but very faintly then the problem could be a loose connection.

Problem: I can't hear myself when transmitting but can hear COM transmissions

Solution: Check the COM side tone setting. For more information see the manual supplied with your COM radio. Remember to check both sides of the aircraft for this condition. The COM side tone applies to both sides of the aircraft equally so using the same headset on both pilot and co-pilot headset positions should yield the same conditions.

Problem: Received COM transmissions are fine but my transmitted voice sounds distorted or there is a high level of background noise.

Solution: The setting of the COM side tone may be set to automatically adjust with the volume level. In some cases this works well but in most instances the side tone may need to be adjusted manually especially when using modern headsets that are more sensitive.

Problem: Only when the COM is turned on there are random loud bursts of noise.

Solution: The default setting of the COM squelch should be adjusted. See troubleshooting section on a random noise through the headset. If you hear Strobe noise only with the COM on read the problem/solution for strobe noise below.

Problem: Only a small portion of the control module volume adjustment potentiometer range is usable.

Solution: Check that all headsets are in stereo mode. If the left and right channels are shorted together with a mono headset it will be impossible to change the left or right volume level for any stereo item such as aux music or EFIS warnings.

The audio mixer was designed to give the most usable range of the volume setting potentiometers for the most common input impedances. If the impedance of the device you are trying to connect is significantly different than the most common impedances the circuit was designed around you may experience a loss of useful range of the volume adjustment potentiometer.

In most cases you may only find that 6 of the available 24 turns in a pot are usable. We still find this situation more pleasant than trying to use a small range of a single turn potentiometer. The usable range will always start at the full clockwise end of the potentiometer range.

A short note on the concept of an audio mixer: The mixer potentiometer is acting as a voltage divider, dividing the signal and sending part of that signal to ground and the rest to the audio amplifier. As you turn the potentiometer clockwise the resistance to ground becomes less and more of the signal is sent to ground thus reducing the volume of that signal. In short you are reducing the volume of each signal with the potentiometer to a desired level. The signals small in volume are then added together (for example Aux1 Left, Aux2 Left and EFIS Left) and amplified to a useable volume. The amplified signal is sent out of the control module on a single wire to the intercom or audio panel.

The volume range may also be dependent on the type of intercom in use. In recent years there has been an increased use of music players designed to drive small ear bud headphones. This results in low volume output from older intercom designs. To compensate, some intercom manufactures have increased the gain level (oversimplified they have turned up the internal output volume knob within the intercom as high as possible). As the mixer output is increased the high level of gain in the intercom causes the signal to become distorted (the top of the signal is being chopped off because the intercom cannot handle that high of input).

Problem: Constant background hiss noise when the aircraft engine is turned off.

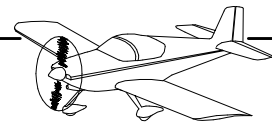
Solution: It is normal to hear a faint ocean sounding noise with the engine turned off with the electrical system powered on. When the engine is running this noise will disappear. The noise will disappear not only because of the sound of the engine which is much greater in magnitude but also because the voltage regulators (especially 12V regulators) in the system will have a greater differential to regulate from when the engine driven alternator or generator brings the bus voltage up to 14V. The greater the difference between the bus voltage and the regulated voltage the better the voltage regulator will be able to maintain a steady voltage for a device such as an intercom. A fluctuating voltage can introduce noise into the system. Note for this reason adding a battery charger may introduce noise into the system.

Problem: Rhythmic jigt jigt noise or banjo noise in the background.

Solution: This noise can be caused if a battery charger has been placed on the battery. Temporarily remove the charger and see if the noise goes away.

The noise may also be caused by serial data transmission along a wire. Try turning off devices that transmit and receive serial data one at a time (for example autopilot, transponder, com radio, ADS-B, GPS, etc...) Although Van's Aircraft has done their best through the use of twisted wires, shielded wires and the use of ground planes this still can be a problem. Try removing tie-wraps from your harnesses and moving wires relative to each other and see if the sound changes. Using an alternate routing path for a noisy wire or shielding wires may be a solution. RS-232 data lines, especially GPS signals, using 9600 baud (9.6 kHz frequency) are particularly susceptible to this; the range of human hearing goes up to 20kHz. If possible use a higher baud rate for the offending RS-232 data line.

If the problem noise is not related to the solution above try the troubleshooting steps listed for a random static noise.



5.21 ELECTRICAL (continued)

Problem: A random static noise comes through the headset.

Solution: Adjust the volume and squelch on the intercom and determine if this will make the noise disappear. If the noise can be controlled with the intercom volume and squelch it means that most likely the noise is being generated by the headset microphone, mic jack, mic hi or mic lo wires. Unplug the headset. If the noise goes away try a different headset. If the noise still persists remove each mic pin from the wiring harness one location at a time and see if the noise goes away (checking the wires connected to the headset jack, wires connecting the headset jacks to the control module and the wires connecting the control module to the intercom). Check that d-sub pins and solder joints all make a proper connection and do not generate the noise when the wires are wigged.

If the noise is not affected by the volume and squelch turn off your radio. If the noise goes away the sound is being generated by your COM. One of the most common issues is the COM receive squelch being broken. A COM radio has an internal squelch setting to control what level of input from the COM antenna will open the COM squelch, similar to how the squelch level is set for the mic on a headset using the squelch knob on an intercom. If set too low, bursts of noise picked up by the antenna may break the squelch. Consult the user manual supplied with your COM radio and turn the receive squelch up slowly until the noise disappears. Note setting the receive squelch too high will prevent your radio from receiving faint transmissions and therefore great care should be taken to set the squelch as low as possible while still eliminating any noise. Conduct this test outside and away from the source of any electronic signals that may be picked up on the antenna.

If the noise is not affected by the squelch or the radio, try the troubleshooting steps listed for a rhythmic noise.

If the problem still persists disconnect the mono and stereo inputs from the back of the intercom one at a time and determine if the noise goes away. This may help isolate where the noise is coming from.

Turn the audio level pots up or down in the control module. If the sound level of the noise problem changes the problem is between the device generating the audio and the control module. If the sound level does not change the problem is between the control module and the intercom, in the intercom or between the headset and the intercom.

If turning off a device removes the noise from the system check that the unit is properly grounded. First remove any wires that are dedicated to audio ground and run the device off its own primary ground. If this does not change the noise run an extra wire from the case of the device to the structure of the aircraft. If the noise still persists consider using a ground loop isolator (GLI) on the wires coming from the device.

When troubleshooting a stereo music input, first disconnect the ground from the music lo or music ground input. Noise coming into an audio system may be transmitted through ground connections to the audio system and most often the music ground/lo. By removing the music lo connection the music will have no connection to ground and the lo will become a "floating ground". Use an aux music device to determine if the music input is still useable. Since the ground is floating possibly higher, the magnitude of the signal will be smaller. A signal with less amplitude will result in less volume.

Problem: My EFIS warning tones are too quiet I can't change the sound levels using the audio mixer on the control module.

Solution: Check that your headsets are turned to *stereo* not *mono* mode. On some headsets this may be a small and hard to find switch see the manual that came with your headset to be absolutely sure you have the headset in *stereo* mode.

Problem: My EFIS is generating a high level of background noise when turned on.

Solution: See the troubleshooting section on a random noise comes through the headset.

Problem: Strobe noise in the headset.

Solution: There are multiple ways the strobe noise will enter the audio system. Try turning the COM radio off and see if the noise goes away. Is the noise only present while the radio squelch is open during receive or transmit? If so the noise is a high frequency RFI noise being picked up on the radio com antenna (some strobes use circuitry in this band, most light manufacturers are now aware of this and have changed their products to remove this issue). Add a choke (magnet that goes around a wire) around the wires coming from each strobe device. Add the choke as close to the device as practical. If all the wires will not go through the choke make sure to at least capture the power and ground wires.

Try also adding a capacitor to the power line. The larger the capacitor the more effective but at some point the inrush current (current filling the capacitor when the circuit is turned on) will blow the fuse on that circuit.

If the above options have not resolved the problem, try shielding the wires for nav/strobe if they have not been shielded already. If the noise is coming in on the mic line (volume of the noise increases when the intercom volume increases with the intercom squelch broken as would be the case if you were talking through the intercom) inspect how your mic line is configured. If the shield for the mic wire is used to provide the mic lo any noise picked up by the shield will be transmitted into the audio system. Older Van's kits were wired this way and in many cases there have been no problems. If this is deemed to be a problem replace the mic wire with a multi-conductor wire that will allow the mic ground to be a separate wire within the shielded bundle.

Dimming (when controlled by Van's control module)

Problem: Interior lights do not come on at all

Solution: Double check that your EFIS is emitting a pulsed dimming signal compatible with LED lighting. Check the EFIS manual or contact your EFIS manufacturer directly. Older EFIS's may output a constant voltage that varies in voltage level with the EFIS dimming level. This constant voltage will never reach ground. The interior lights will only turn on when the control signal goes to ground.



5.21 ELECTRICAL (continued)

EMS

Problem: My EMS display values randomly spike causing warnings.

Solution: If for example the value of an EGT is randomly going high enough to generate a warning on the EFIS, check the quality of all the harness connections. Check if wiggling the spade connector between the thermocouple wires and the wires going back through the firewall recreates the problem. Also move the harness back and forth that goes into any d-sub type connection. If the connection is severed some EFIS systems we default to an error value that is very high, which will in turn generate a warning. If you have a bad connection that intermittently becomes disconnected you will then be generating intermittent warnings.

Some values that spike can be fixed by changing the sampling rate of a signal or by changing how the data collected is averaged and over what amount of time the average takes place. Consult the instructions provided with your EFIS system or the EFIS manufacture.

Problem: My EMS values randomly spike during transmit.

Solution: RFI leakage from the com antenna may affect the EGT or MP wires. This is a common issue with the Van's gauges and has not been a major problem.

If using a Dynon Avionics SkyView system, and the CHT and EGT readings spike during COM transmit: This is a known issue with older SkyView SV-EMS-220 modules, which Dynon can fix. Contact Dynon Technical Support. Mention that you have a SkyView system and CHT/EGT is spiking during COM transmissions.

GPS

Problem: My EFIS is not detecting a GPS signal.

Solution: Check that the output format of the GPS signal is set correctly. You may have no control of the output format of a GPS puck but for a device like a Garmin handheld GPS etc. there will be a menu driven option allowing different formats.

Check that the wire carrying GPS data to the ELT has not been accidentally grounded by

- a) crimping the shield to main wire conductor (Refer to Section 5 in your builder manual for the proper termination of shielded wires)
- b) no connection to the ELT thus the wire is dangling and grounding out on aircraft structure. Cover the end of the conductor in heat shrink.

Trim

Problem: Trim motor does not move, or low voltage present at trim motor

Solution: The trim speed is controlled by a pulsed voltage (ie the power is turned on and off quickly - the longer it is off the slower the motor moves). Adjust the trim potentiometer CCW to increase the speed. Most voltmeters will average the pulsed voltage as something less than buss voltage (for example a pulsed voltage with a peak voltage of 12V off 50% of the time would be seen as 6V on a typical voltmeter).

Glossary of Electrical Terms

These definitions are not meant to be “scientifically” correct but rather a definition understandable to someone not technically familiar with electrical systems.

EMI and EMR (RFI): Electro Magnetic Interference. A magnetic field if oriented correctly near a wire will move electrons within the wire inducing a current and causing electrical “noise”. This is referred to as “near field” since the effect falls off rapidly. This is why moving wires relative to or away from a source may solve an EMI problem. A common source would be a wire carrying a fluctuating high current.

Electro Radiation Interference (or Radio Frequency Interference when in the radio frequency spectrum) is energy absorbed or emitted from a charged particle and will continue to travel through space away from the source. This is referred to as “far field” and in such cases a solution should if possible be applied to the source of the radiation. A common source would be a COM and the transmit wire / antenna.

With any electromagnetic radiation interference small signals such as audio are more likely to be affected.

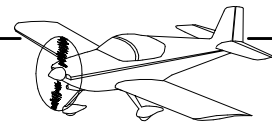
Gain: Amplification of a signal (for the sake of this manual audio signal)

Impedance: The equivalent resistance of an electrical device.

Quiescent Current Consumption: Power consumed by a device in the idle state.

Side tone: Sound from a headset microphone fed back into the earpiece of that same headset or the level at which you hear your own voice in the head set when transmitting. For more information consult your COM radio installation and user manual.

Squelch: A level setting used to cancel background noise so that only signals above the set level will be heard. The term “breaking the squelch” means that an incoming signal has a level high enough to be above this level and will be heard.



5.22 COMPRESSION FITTINGS IN PLASTIC TUBING

Install compression fittings to plastic tubing using the following steps:

Step 1: Drill #29 the inside of the tube.

Step 2: Blow out the tube using compressed air from the end opposite the one which was drilled.

Step 3: Slide the nut and sleeve over the plastic tube, then locate the sleeve about 1/8 inch from the end. See Figure 1.

Step 4: Press the brass insert into the end of the plastic tube as far as possible by pushing it against some solid object. Place the end of the assembly in boiling water for one minute, then immediately press the insert in the rest of the way until it bottoms against the end of the plastic tube.

Step 5: Tighten the nut finger tight, then one full turn thereafter.

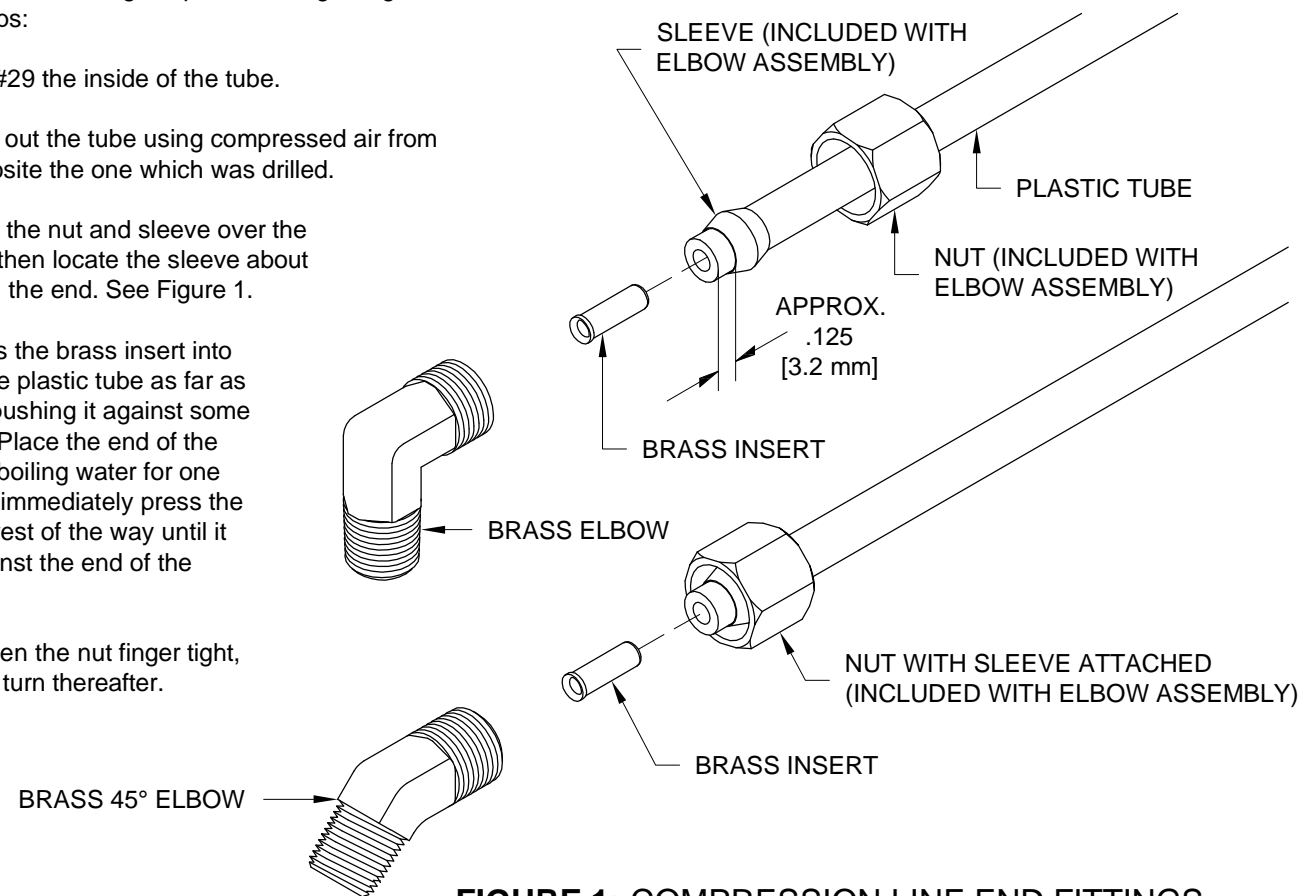


FIGURE 1: COMPRESSION LINE END FITTINGS

5.23 NYLON FLUID FITTINGS IN PLASTIC TUBING

Install nylon fittings to PT-062X1/4 Plastic Tube using the following steps:

Step 1: Cut tube squarely and remove any burrs.

Step 2: Place insertion mark .625 [15.9 mm] from end of tube. See Figure 2. Moisten marked end of tube with water.

NOTE: Nut, keeper, collar and O-ring are in place on the fitting at this point.

Step 3: Install plastic tube into nylon nut by pushing end of moistened tube straight into the nut until the tube bottoms on the tee's shoulder.

Step 4: Finger tighten nylon nuts. Additional tightening should not be necessary, but 1/4 additional turn may be added if desired. **DO NOT OVER TIGHTEN** nut or threads will strip and fitting will not function properly. A proper assembly will not show insertion mark extending beyond the nut. If insertion mark is visible, then repeat steps 3 and 4.

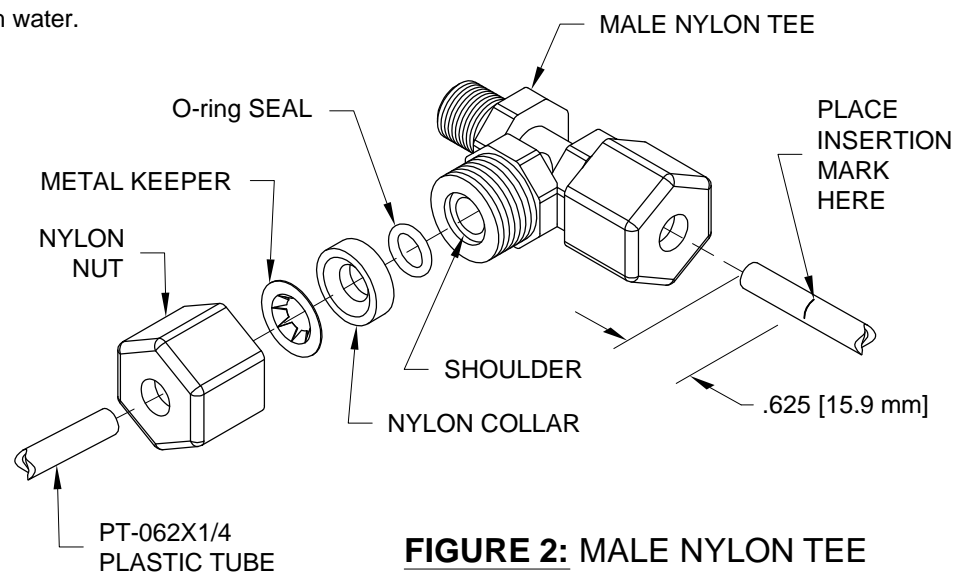


FIGURE 2: MALE NYLON TEE EXPLODED VIEW

5.24 DRILLING, TAPS AND DIES

Material alloy and hardness, as well as the makeup of the cutting tool determine the speed at which metal is best drilled. For the purpose of this discussion, we assume that the drill used is High Speed Steel (HSS). Cutting speed is stated in surface feet per minute or abbreviated as FPM and is a measure of the peripheral speed of the drill. Softer materials can be cut at a higher speed than harder materials. Smaller drills have to turn faster than larger drills to achieve the same FPM cutting speed.

For the most part, the materials we are concerned with in RV construction are aluminum and steel. The aluminum is of various alloys, but we can use 200 FPM as a cutting speed for all of them. The steel is 4130 chrome molybdenum alloy. We can use a cutting speed of 60 FPM for 4130.

Drilling most of the aluminum in RV construction can be done dry, without any oils or cutting fluid. When drilling holes more than three diameters deep, a few drops of kerosene or Boelube helps. For holes larger than 1/4" in thin material a "Unibit" makes a cleaner hole.

Steel is best drilled with at least some oil. Practically any oil, WD-40 etc. can be used. There is no need to get sloppy. Use just enough oil to lubricate and carry off some heat. Drilling steel requires considerably more feed pressure, or thrust, than aluminum.

The chart below is general in nature. Interpolate speeds for sizes not listed. Notice the drill speeds for aluminum are higher than any of our hand held drills are likely to go. This is why air drills are superior to electric drills when drilling aluminum. It is also assumed that the drills are sharp and the setup is rigid, as in a drill press.

Drill RPM						
Drill Size	#40 0.098	#30 0.128	#12 0.189	0.250	0.375	0.500
Material Aluminum (200 FPM)	7796	5946	4198	3056	1748	1528
Steel (60 FPM)	2339	1784	1213	917	611	459

When drilling with a hand drill it is advisable to start the drill turning slowly, then increase the RPM after the drill is centered and stabilized in the hole. Drill a straight hole by aligning the drill with its reflection in the shiny aluminum surface. The small drills that we use in RV building are of the split point style and need special equipment to sharpen. As many as a dozen each of #30 and #40 will be needed to complete the project. Do not skimp on drill bits; when they get dull replace them.

See Section 5.19 for tips on drilling Plexiglas.

DRILLING TERMINOLOGY

Fundamentally, and unless otherwise noted, "drilling" shall be understood as comprising the following basic sequence of procedures; having material(s) in hand, acquiring hole size and position from the drawing, transferring hole location to the part through measurement or other means, marking the hole location, center-punching hole location, drilling through the material or materials.

Match-drill refers to drilling a stack of two or more parts in which a hole is already located in the first part. Drilling through the existing hole in the first part results in a matching hole(s) in the other part(s) in the stack.

Final-drill refers to drilling one or more parts that already have a hole in the location to be drilled. A final pass is made through the existing hole with the specified size drill bit.

Deburr all drilled holes before dimpling or riveting.



5.24 DRILLING, TAPS AND DIES (continued)

SOME NOTES ON TAPS

A "tap" is a tool used for cutting internal threads into an existing hole. Taps come in several styles. The most common hardware store variety is a four-flute tap. The flute is the groove along the length of the tool. When using a tap on metal, some lubricant should be used. Common motor oil is OK for steel while kerosene works well on aluminum. Plastic needs no lubricant.

Starting the tap straight in the hole is very important. Most broken taps are due to hole misalignment. The best way to get the tap started straight is to use a drill press. Clamp the work in a vise and with the tap in the chuck, turn the chuck by hand.

When tapping a deep hole it is best to back the tap out about one turn to every two turns in. In this way the resulting chips are allowed to clear from the flutes. Do not allow the tap to get stuck by turning too many times without clearing; another cause of broken taps.

An 8-32 tap means that the screw size is #8 and it has 32 threads per inch (pitch). Fractional sizes like 1/4-20 mean the screw is 1/4" and has 20 threads per inch.

5.25 DIMENSIONS

Dimensions in newer kits are depicted in English fractional form with a 1/32 inch accuracy where possible. Other dimensions, not lending themselves readily to a 1/32 of an inch conversion, are depicted in decimal form with a three decimal place accuracy. We realize that most tape measures do not have three decimal place accuracy, and so have provided a conversion table to facilitate conversion between fractions and decimals.

Holes as provided in the kit will be called out as decimals, but after drilling, they will be referred to by the drill bit size used to drill them. Example: "Drill #40 the .094 [2.4 mm] holes in the dingus. Dimple the #40 holes."

In many cases, use of the nearest fractional measurement to a decimal place dimension is sufficient, but use your best judgement, especially in areas that may require high precision to fit correctly.

All dimensions are also depicted in metric measurements.

FIGURE 1: FRACTION TO DECIMAL CONVERSION			
1/32	0.032	17/32	0.531
1/16	0.063	9/16	0.563
3/32	0.094	19/32	0.594
1/8	0.125	5/8	0.625
5/32	0.156	21/32	0.656
3/16	0.188	11/16	0.688
7/32	0.219	23/32	0.719
1/4	0.250	3/4	0.750
9/32	0.281	25/32	0.781
5/16	0.313	13/16	0.813
11/32	0.344	27/32	0.844
3/8	0.375	7/8	0.875
13/32	0.406	29/32	0.906
7/16	0.438	15/16	0.938
15/32	0.469	31/32	0.969
1/2	0.500	1 1/2	1.000

5.26 HARDWARE REFERENCE

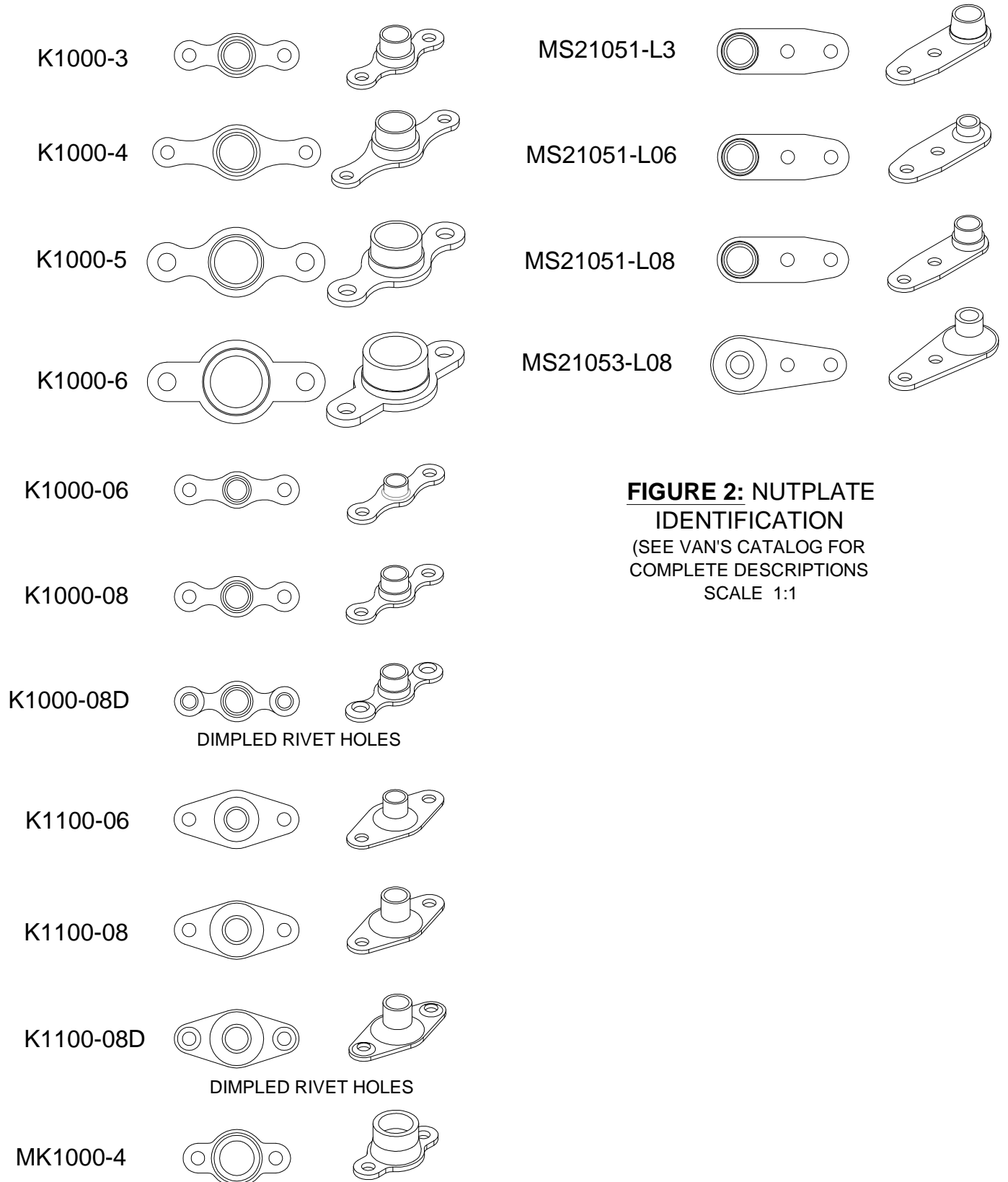
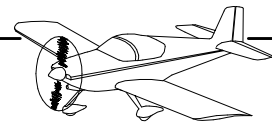


FIGURE 2: NUTPLATE IDENTIFICATION
(SEE VAN'S CATALOG FOR COMPLETE DESCRIPTIONS)
SCALE 1:1



5.26 (continued)

	FLUSH HEAD	PROTRUDING HEAD
AACQ-4-3		
AACQ-4-4		
AACQ-4-6		
AD-41-ABS		
AD-41H		
AD-42H		
AD-62-BS		
AK-42H		
CCR-246SS-3-2		
CR-3212-4-2		
CR-3212-4-3		
CR-3212-4-6		
CR-3213-4-2		
CR-3213-4-3		
CR-3213-4-4		
CR-3213-4-5		
CR-3213-5-6		
CS4-4		
LP4-3		
LP4-4		
LP4-5		
MK-319-BS		
MSP-42		
N BSPQ-5-4		
SD-42-BSLF		

FIGURE 1: BLIND RIVET IDENTIFICATION
(SEE VAN'S CATALOG FOR COMPLETE DESCRIPTIONS)
SCALE 1:1

10 9/16

FIGURE 2: NAS1149 AND AN960 WASHER SUBSTITUTION

NAS1149 washers may be used anywhere a AN960 washer is called for. However, **DO NOT** use a AN960 washer where a NAS1149 washer is specified. Manufacturing tolerances for the NAS1149 washers are tighter than are those for the AN960 washers.

AN Part No.	NAS Part No.
AN960-4L	NAS1149FN416P
AN960-4	NAS1149FN432P
AN960-6	NAS1149FN632P
AN960-8	NAS1149FN832P
AN960-10L	NAS1149F0332P
AN960-10	NAS1149F0363P
AN960-416L	NAS1149F0432P
AN960-416	NAS1149F0463P
AN960-516L	NAS1149F0532P
AN960-516	NAS1149F0563P
AN960-616L	NAS1149F0632P
AN960-616	NAS1149F0663P
AN960-716	NAS1149F0763P
AN960-816L	NAS1149F0832P
AN960-816	NAS1149F0863P
AN960-916	NAS1149F0963P
AN960-1016	NAS1149F1063P
AN960-1216	NAS1149F1290P
AN960-2016	NAS1149F2090P



5.26 (continued)

FIGURE 1: ROD-END BEARING REFERENCE CHART

PART NO.	STUD	BEARING HOLE	LENGTH	THICKNESS	
MW-3M	3/16" FEMALE	3/16	1 3/8	0.31	
F3414M	1/4" FEMALE	3/16	1 3/4	7/16	
F3514M	5/16" FEMALE	3/16	1 3/4	7/16	
MM-3	1/8" MALE	3/16	1 1/4	5/16	
CM-4M	1/4" MALE	1/4	1.94	3/8	
M3414M	1/4" MALE	3/16	1.94	7/16	
MD3616M	3/8" MALE	3/16	2 1/4	1/2	
MD3614M	3/8" MALE	3/16	1 3/4	7/16	
MD3616M	3/8" MALE	3/16	2 1/4	1/2	
GMM-4M-675	3/8" MALE	1/4	2 3/4	1/2	
CM-4S	1/4" MALE	1/4 STUD	1.94		

5.27 FLUID FITTINGS

PIPE THREAD FITTINGS

Many fittings used in RV plumbing systems have tapered pipe threads. Tapered pipe threads have an outside diameter which decreases toward the opening. Therefore, as the fitting is threaded into a normally threaded hole, the clearance between the two diminishes until the fitting becomes tight. To a large degree this interference fit is what provides the high pressure seal. Some fittings have 45 or 90 degree angles which require positioning (clocking) in a specific direction and may prevent them from being turned to the fully seated point (though this should be done on all straight fittings that allow doing so).

NOTE: There are a few locations where the fittings used have straight threads (usually fittings or sensors installed on engines). In these cases, some type of crush gasket or O-ring is used to provide the seal (no paste or liquid sealant is used). One obvious indicator of a straight thread fitting/sensor is that it can easily be fully threaded in until it bottoms out in the hole.

All of the threaded fittings used in RVs are NPT (National Pipe Thread), which is a U.S. standard for tapered threads used on threaded pipe and fittings. There is often confusion regarding the size designations because it pertains to the nominal inside diameter of the fluid passage, not the outside diameter of the fitting.

Two methods are provided for tapered fitting identification. See Page 05-29, Figure 1 for full scale drawings or refer to Table 1 for use in identifying a fitting's designated size. To use the table measure the maximum outside diameter (OD) of the tapered thread, locate this value under the "Actual Size (OD)" column, and read the corresponding NPT fractional value from the "Designated Size" column.

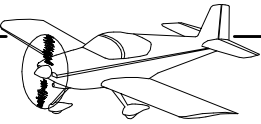
Actual Size (OD)	Designated Size
0.405 in. [10.29 mm]	1/8
0.540 in. [13.72 mm]	1/4
0.675 in. [17.15 mm]	3/8

TABLE 1: NPT SIZES

Because we cannot always fully tighten tapered thread fittings, and because even after fully tightening the fitting a small spiral leak path remains along the full length of threads, a thread sealant must be used during assembly. Sealants appropriate for use on aircraft NPT fittings are Tite-seal, Permatex #2 and Loctite 565. **Do not use RTV, Teflon tape or Fuel Lube on NPT fittings.**

When installing the fitting, be sure the threads on both parts are clean and dry since most sealants will not tolerate any oil contamination. First determine the clocking position by installing it finger tight and marking the desired clocking. Remove the fitting and apply a small amount of sealant to 2 - 3 threads of the male fitting. Leave the first 2 bare to prevent contamination inside the fluid path. Remember, this is an interference fit so not much sealant is required.

Thread the fitting in with your fingers until you just begin to feel resistance and then an additional 1.5 - 2 turns. This is a general guideline... you must still use judgment to not over tighten and damage the threads, but a properly installed fitting is quite tight. If the installation requires a specific clocking, when approaching the correct position you must determine whether you will be able to make another full rotation and still be within the 1.5 - 2 turns stopping range. You must avoid turning the fitting backwards in the loosening direction because it will have a high probability of leaking. If you must do this, it is best to completely remove the fitting, clean up the threads on both parts, and try again.



5.27 FLUID FITTINGS (continued)

NOTE: Fitting depictions are intended for general identification purposes only. All threads, except for those at or adjacent to flared ends, are tapered NPT threads even though they may not be shown tapered.

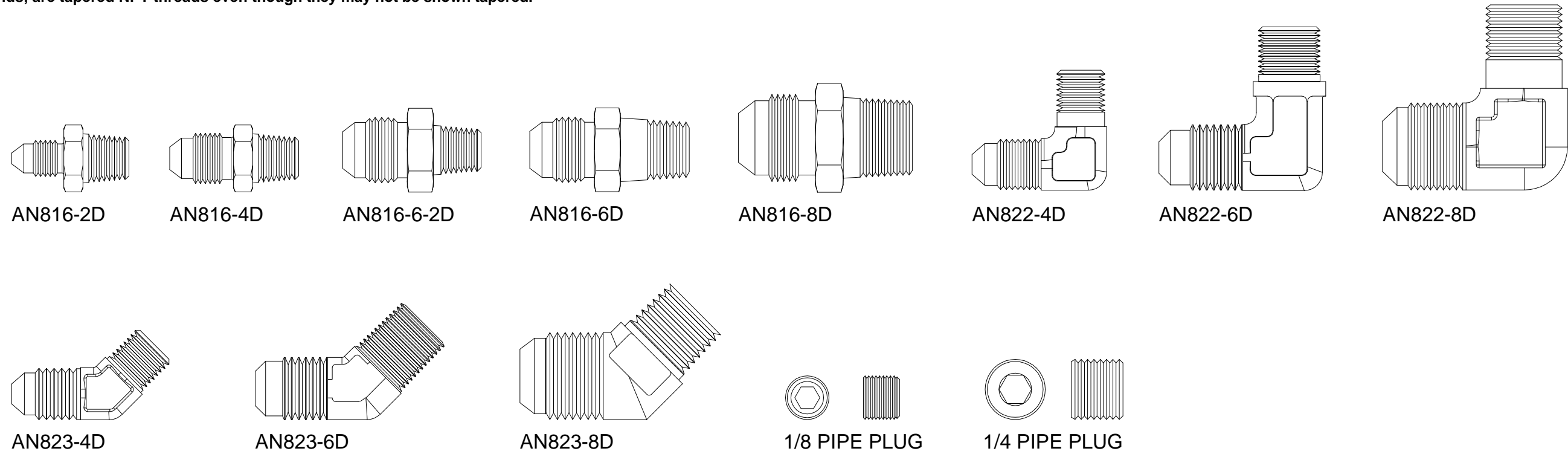


FIGURE 1: FITTING IDENTIFICATION
(SEE VAN'S CATALOG FOR COMPLETE DESCRIPTIONS)
SCALE 1:1

10 9/16

FLARED FITTINGS

For identification see Figure 2 for a selection of flared fluid fittings.

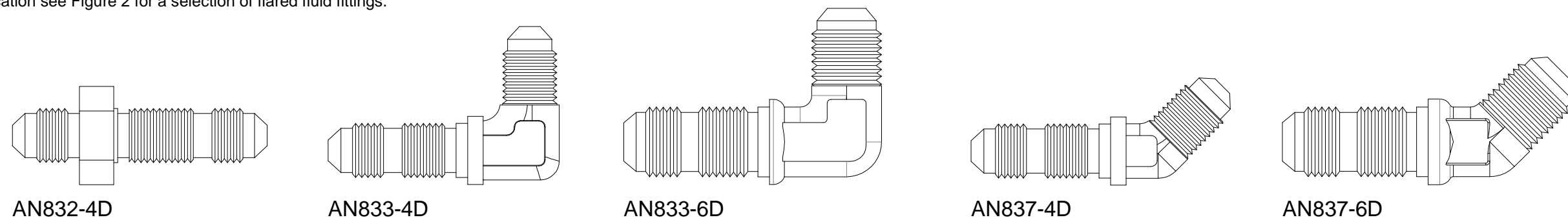


FIGURE 2: FITTING IDENTIFICATION
(SEE VAN'S CATALOG FOR COMPLETE DESCRIPTIONS)
SCALE 1:1

5.27 FLUID FITTINGS (continued)

STRAIGHT THREAD FLUID FITTINGS

Some fluid fittings (such as those installed in a typical Lycoming style Fuel Pump) are based on a straight thread and O-Ring arrangement. These threads do not taper like an NPT fitting.

To install fluid elbow-type fittings of this configuration, thread the fitting into the receptacle until the O-Ring is partially compressed into the chamfer, clock the fitting to the correct angle, then fully torque the nut.

NOTE: Torque values provided in Figure 1 and Figure 2 are for -6 (9/16 - 18 thread) fittings ONLY.

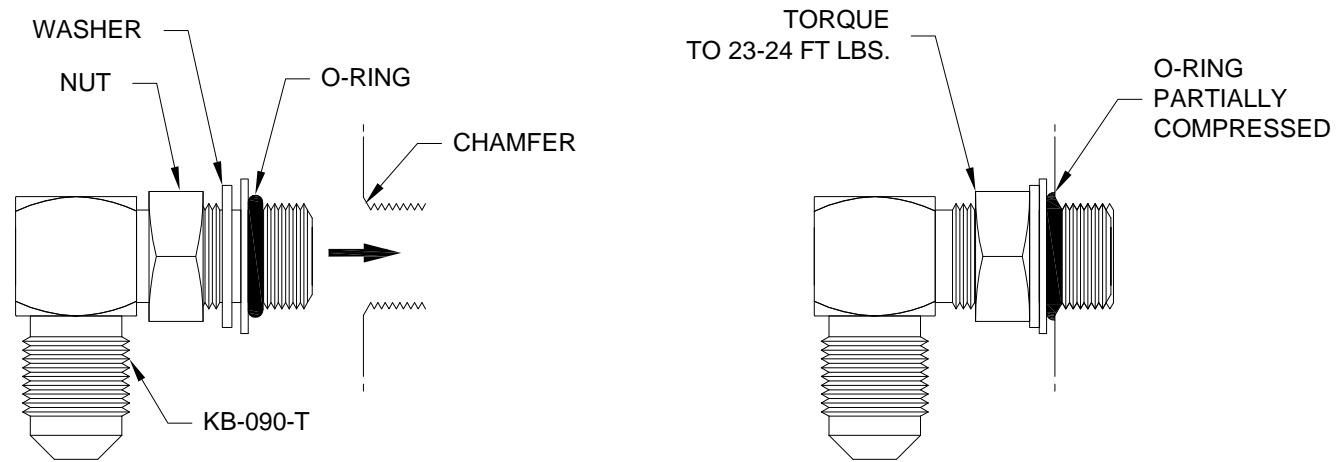


FIGURE 1: ELBOW-TYPE STRAIGHT THREAD FLUID FITTING

For straight-type fluid fittings of this configuration, thread the fitting into the receptacle until the O-Ring is partially compressed into the chamfer, then fully torque the fitting.

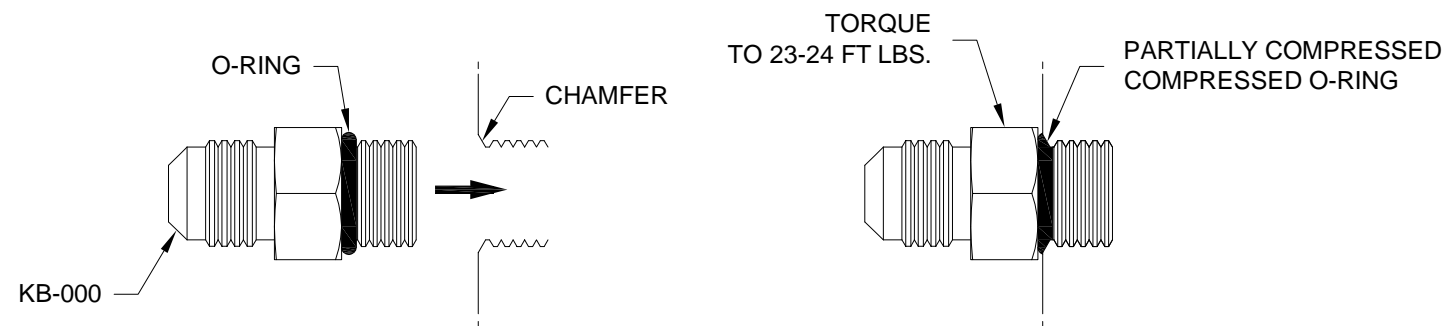


FIGURE 2: STRAIGHT-TYPE STRAIGHT THREAD FLUID FITTING

5.28 CONCLUSION

The manual now changes from general information to specific building instructions for your new airplane. The information is presented in logical, step-by-step order. This DOES NOT mean that the construction sequence given is the only way to do things; depending on factors such as available help, available space, or just personal preference, you might well alter some procedures with good results. Nor does it mean that you should simply follow the instructions blindly, one step at a time, without thinking ahead.

While the manual has been crafted in such a way as to minimize contradictions between the instructions provided by Van's and the instructions provided with a part/assembly that is included in the kit (wheels and brakes for example), **should there be an instance where the instructions from Van's contradict the instructions provided with a particular kit component, those of the component manufacturer shall take precedence over those provided by Van's.**

Successful use of this manual requires your active participation. Before you begin building, **READ THE ENTIRE SECTION**. Read it two or three times. Visualize the operations described, think about what might come next, consider what consequence your actions might have. **NEVER** do anything in a hurry. A great deal of a homebuilder's time is spent staring into space, making odd motions with the hands as he or she imagines how things might fit together. This is not wasted time! It is essential to forming a clear mental image of the task ahead.

Read Section 5 again and be familiar with the proper techniques needed for construction.