

# SECTION 22iS/U: FWD LOWER FUSELAGE

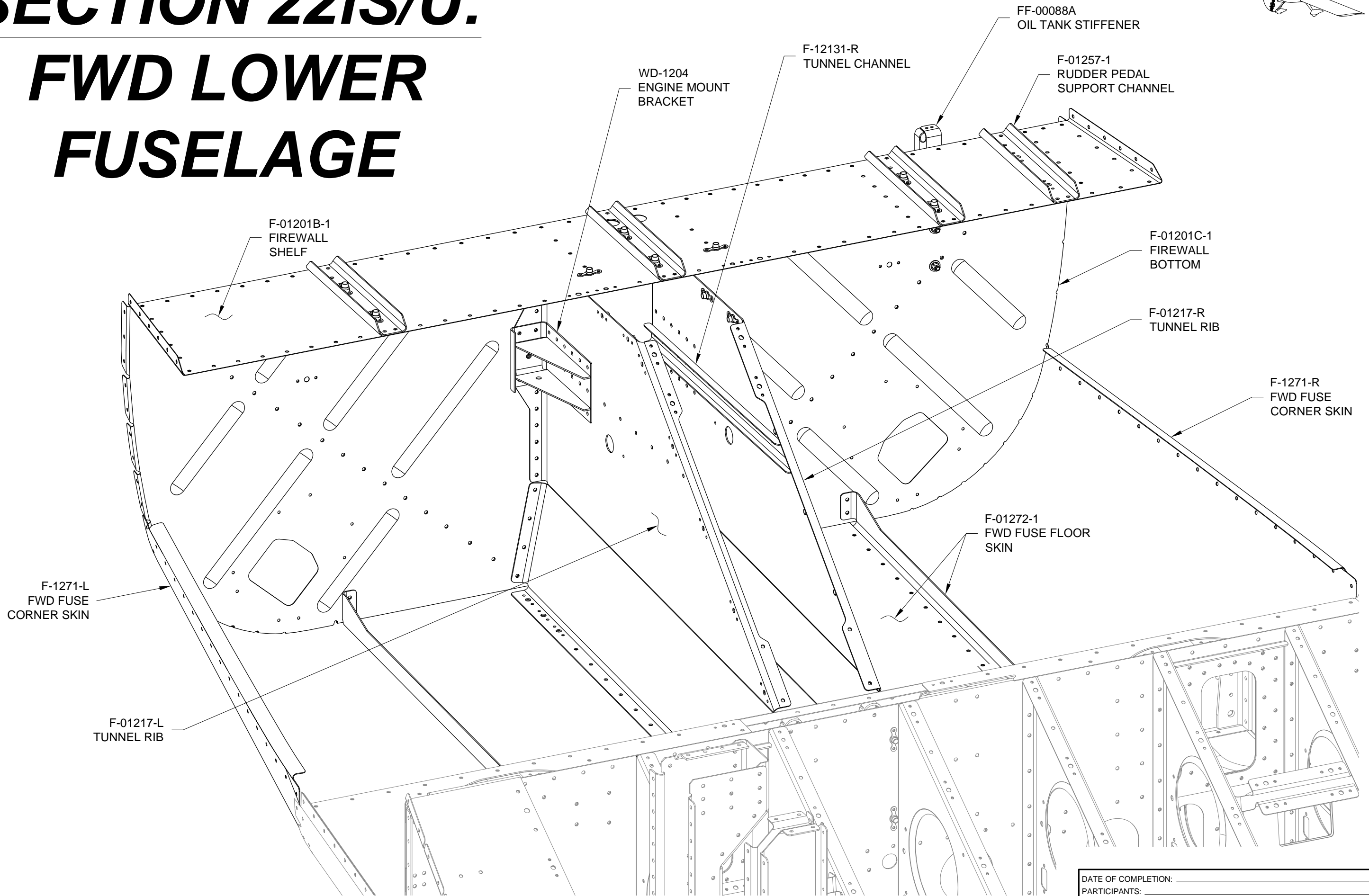



Step 1: Separate and deburr the parts depicted in Figures 1 through 4. Remove the hatched areas as shown.

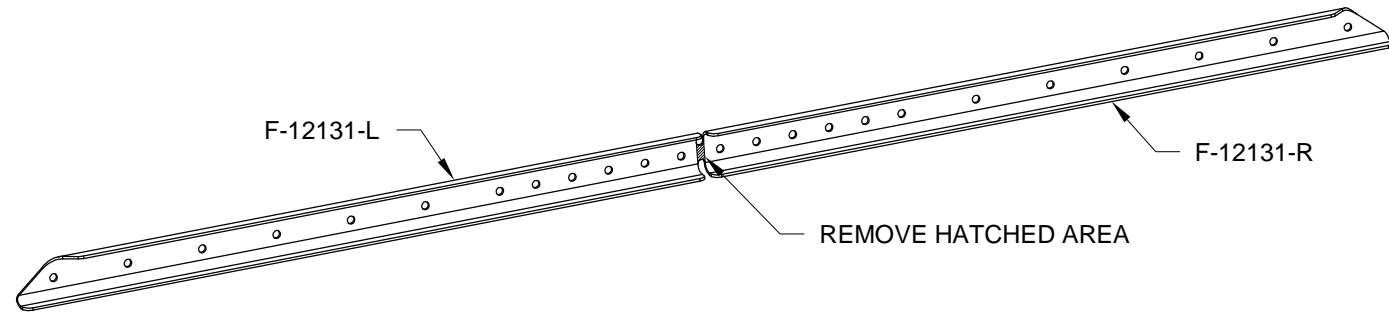

FIGURE 1: SEPARATING F-12131

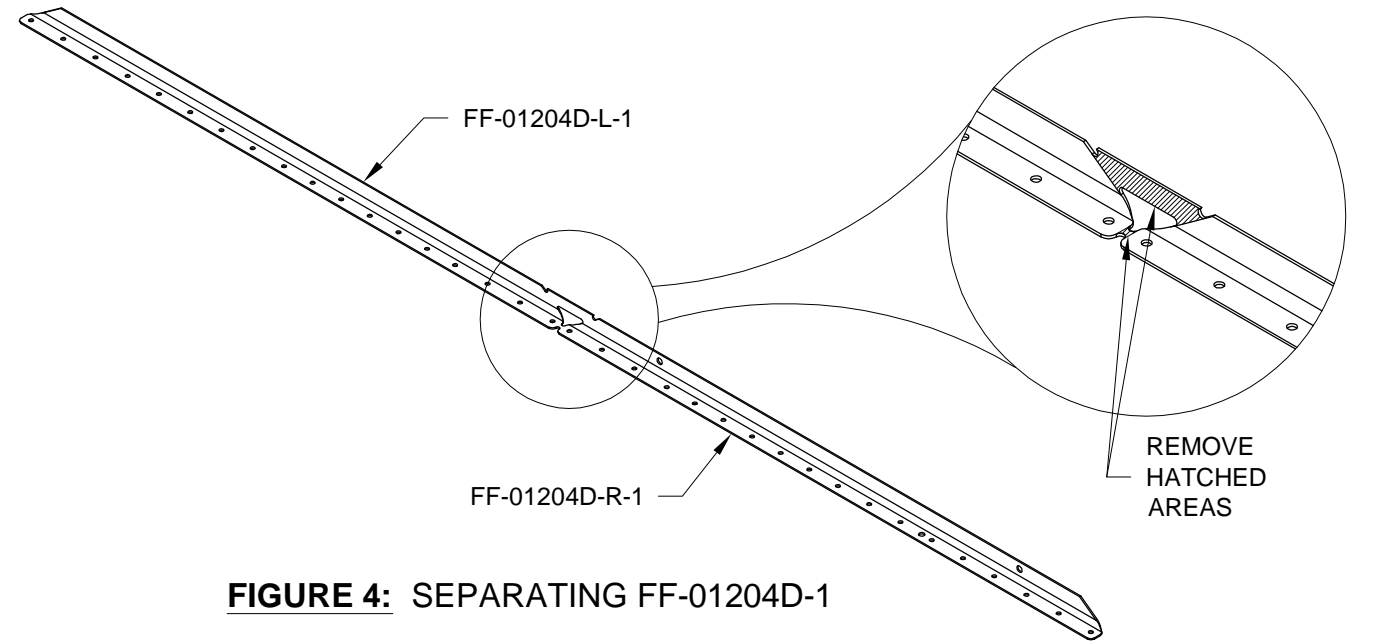

FIGURE 4: SEPARATING FF-01204D-1

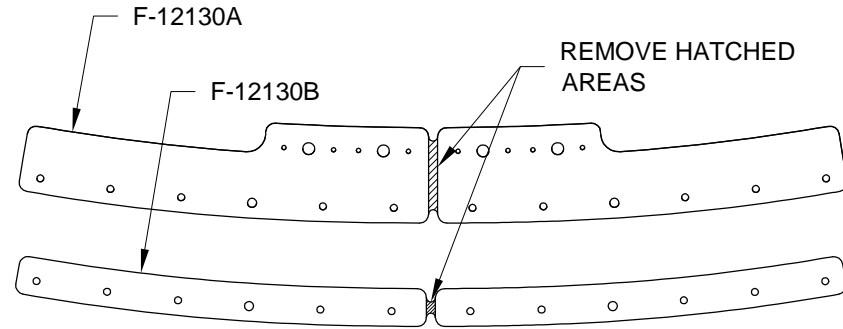

FIGURE 2: SEPARATING F-12130A & F-12130B

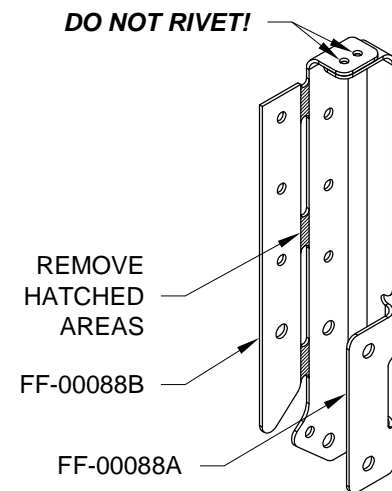

FIGURE 3: SEPARATING FF-00088AB

Step 2: Separate and deburr the F-01257-1 as shown in Figure 5.

Step 3: Dimple #30 the called out rivet holes in each F-01257-1.

Step 4: Dimple #40 the called out nutplate attach holes in three F-01257-1.

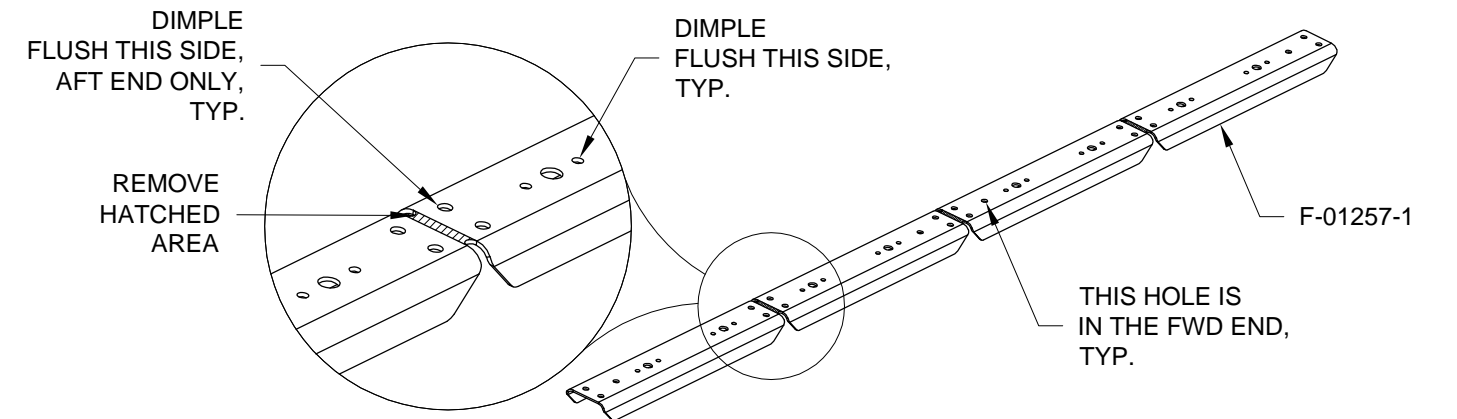

FIGURE 5: SEPARATING F-01257-1

Step 5: Fabricate two FF-00093 from AT6-058X5/16 per Figure 6 dimensions.

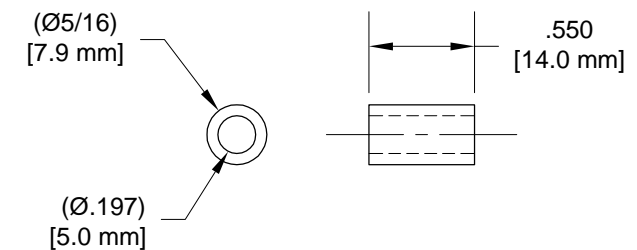
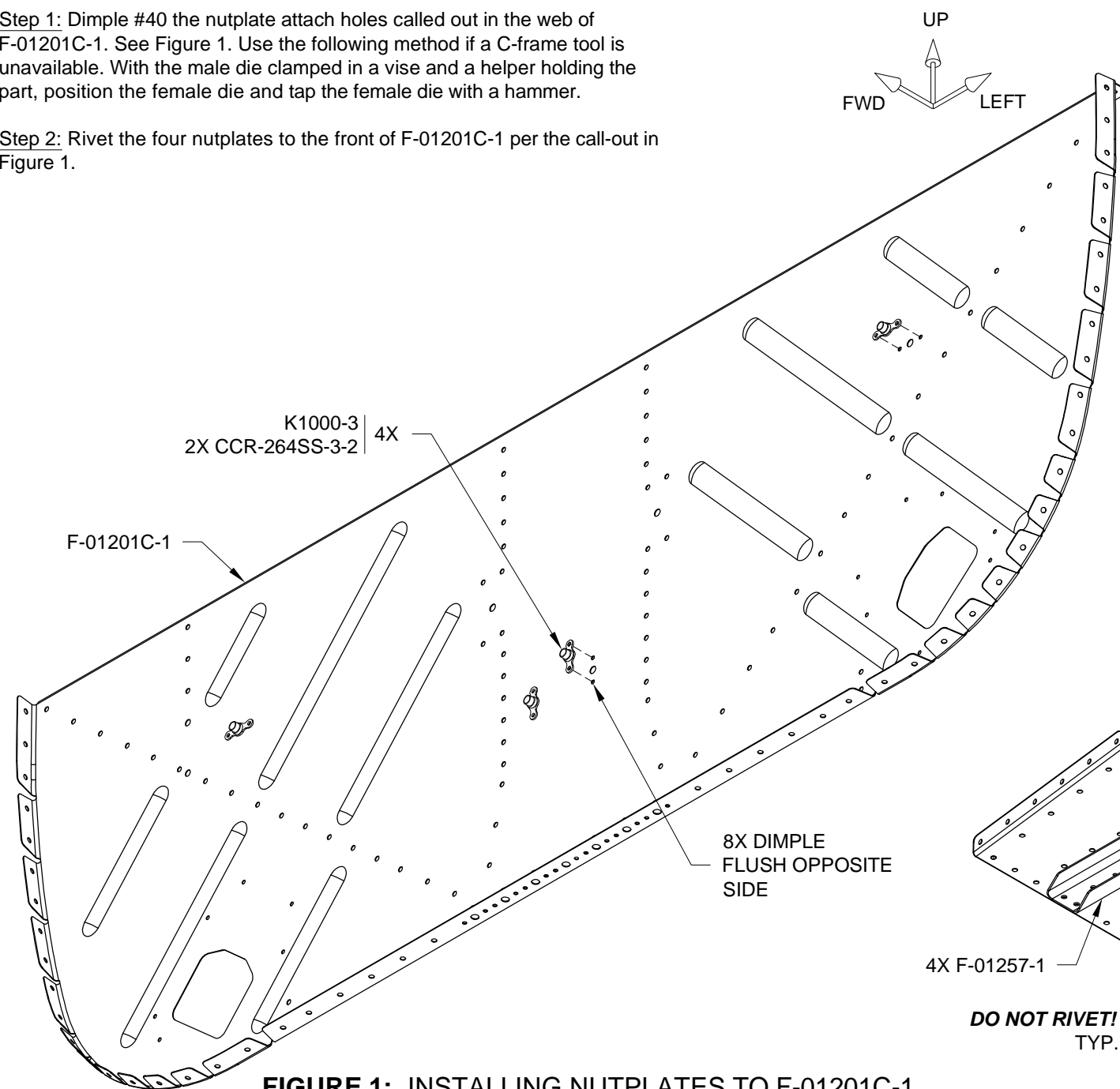

FIGURE 6: FABRICATING FF-00093



Step 1: Dimple #40 the nutplate attach holes called out in the web of F-01201C-1. See Figure 1. Use the following method if a C-frame tool is unavailable. With the male die clamped in a vise and a helper holding the part, position the female die and tap the female die with a hammer.

Step 2: Rivet the four nutplates to the front of F-01201C-1 per the call-out in Figure 1.



**FIGURE 1: INSTALLING NUTPLATES TO F-01201C-1 (BOTTOM ISOMETRIC VIEW)**

Step 3: Machine countersink #40 the nutplate attach holes in the bottom surface of F-01272-1 per Figure 2.

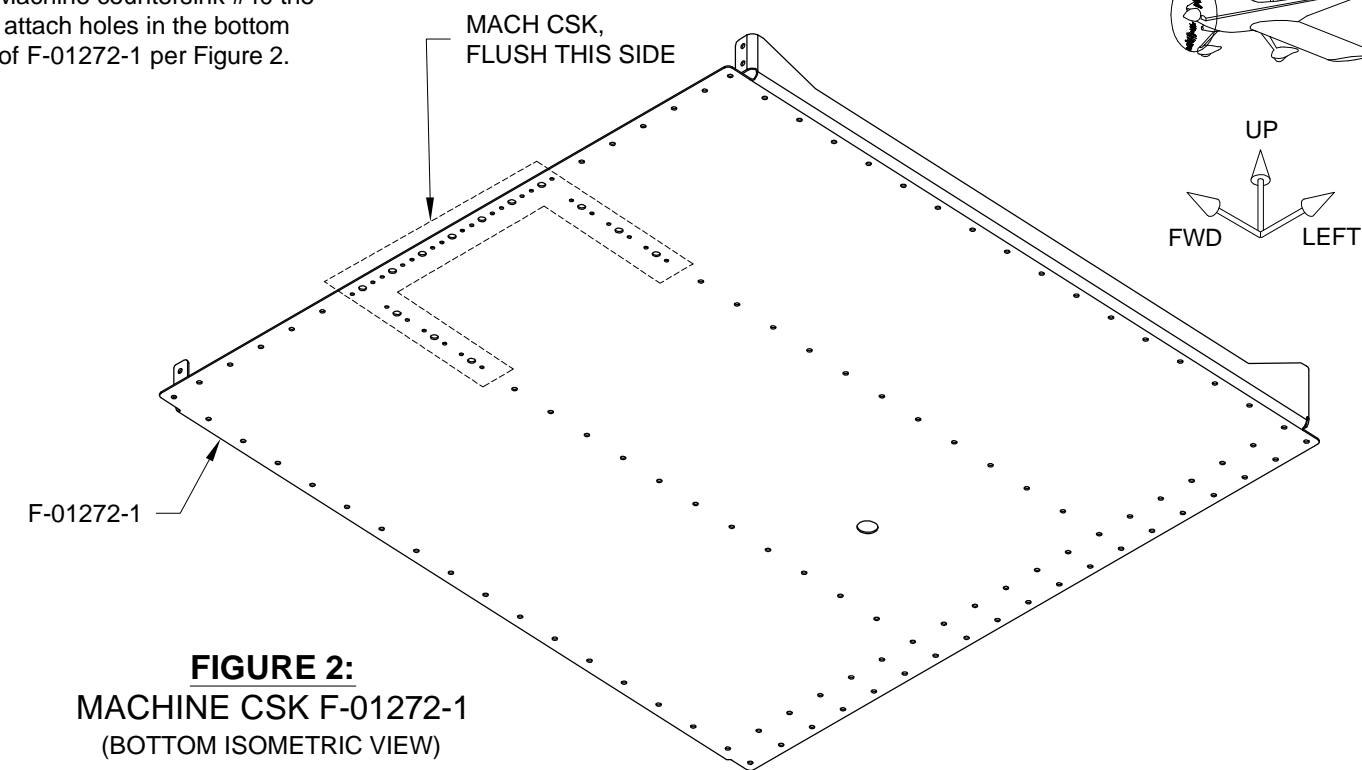

**FIGURE 2: MACHINE CSK F-01272-1 (BOTTOM ISOMETRIC VIEW)**

Step 4: Dimple #30 the aft holes in F-01201B-1 that correspond to F-01257-1. See Figure 3.

Step 5: Dimple #40 the called out nutplate rivet holes in F-01201B-1.

Step 6: Cleco the center F-01257-1 to F-01201B-1. Use a step drill to enlarge the fwd #30 hole in the F-01257-1 up to the diameter of the corresponding hole in F-01201B-1. Draw a crosshair across the holes to keep holes centered while drilling.

Step 7: Rivet the two nutplates just outboard of the center F-01257-1.

Step 8: Rivet F-01257-1 to F-01201B-1 along with the nutplates where applicable. **DO NOT RIVET** the aft most nor the fwd most holes.

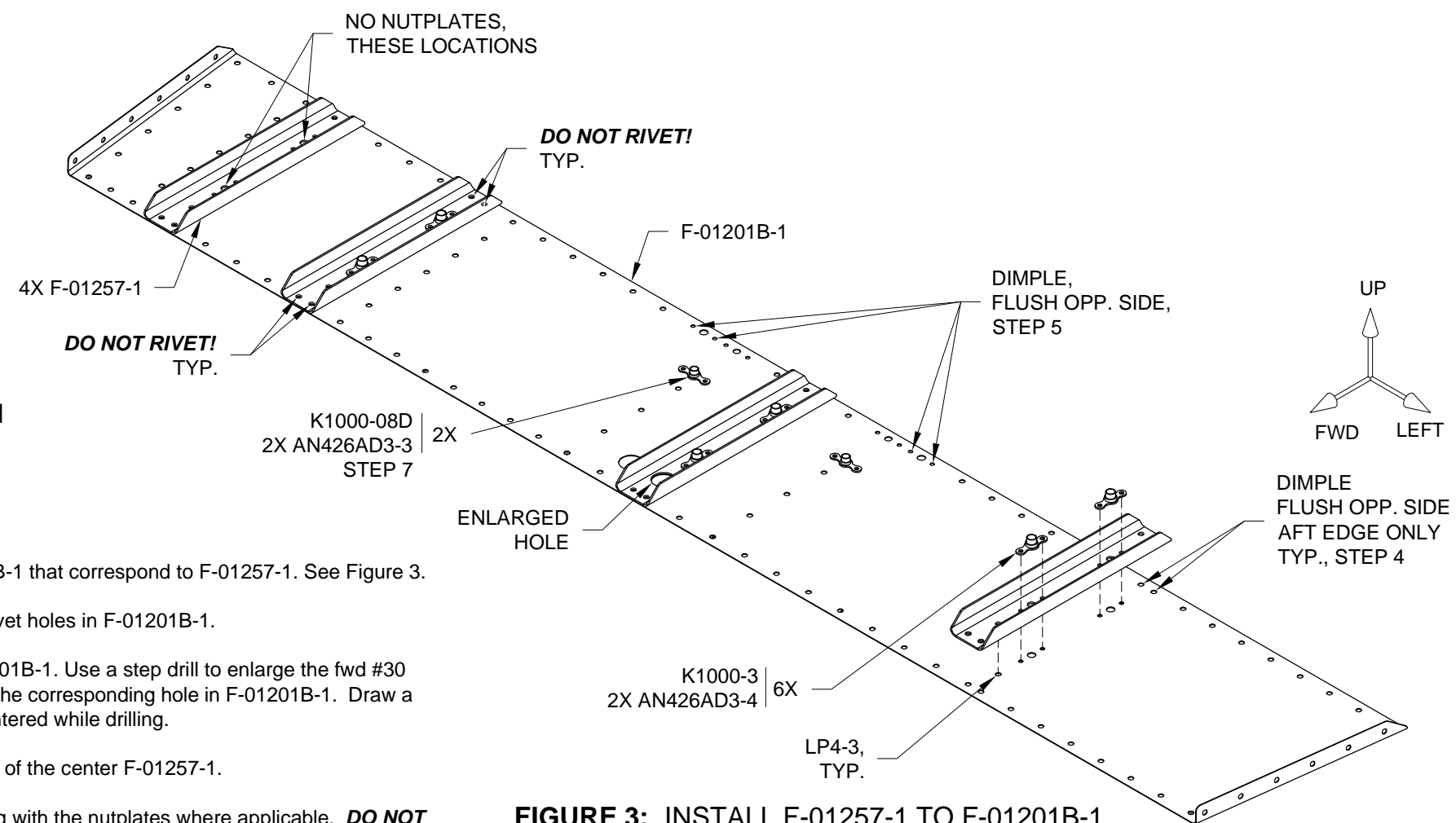

**FIGURE 3: INSTALL F-01257-1 TO F-01201B-1**



Step 1: Machine countersink #40 the nutplate attach holes in F-01217-L per Figure 1.

Step 2: Machine countersink #30 the fwd flange of F-01217-L, with WD-1204 in place, to receive the dimpled firewall.

Step 3: Dimple #30 the hole in F-01217-L and F-12131-L.

Step 4: Use a step drill to enlarge the fwd #30 hole in the web of F-01217-L (aft hole in F-01217-R) to 5/8 in. Draw a crosshair across the hole to keep the holes centered during drilling.

Step 5: Cleco then final-drill #30 all of the rivet holes in WD-1204 to F-01217-L.

**CAUTION: DO NOT rivet to the fwd flange of F-01217-L at this time.**

Step 6: Cleco then rivet WD-1204 and F-12131-L to F-01217-L as shown. Place the manufactured head of the rivet on WD-1204 except where noted. Note the location of the single Cherry rivet.

Rivet nutplates to F-01217-L.

Step 7: Repeat Steps 1-6 for F-01217-R.

Step 8: Cleco then rivet F-01217-L & -R to F-01272-1 using the hardware called out in Figure 2.

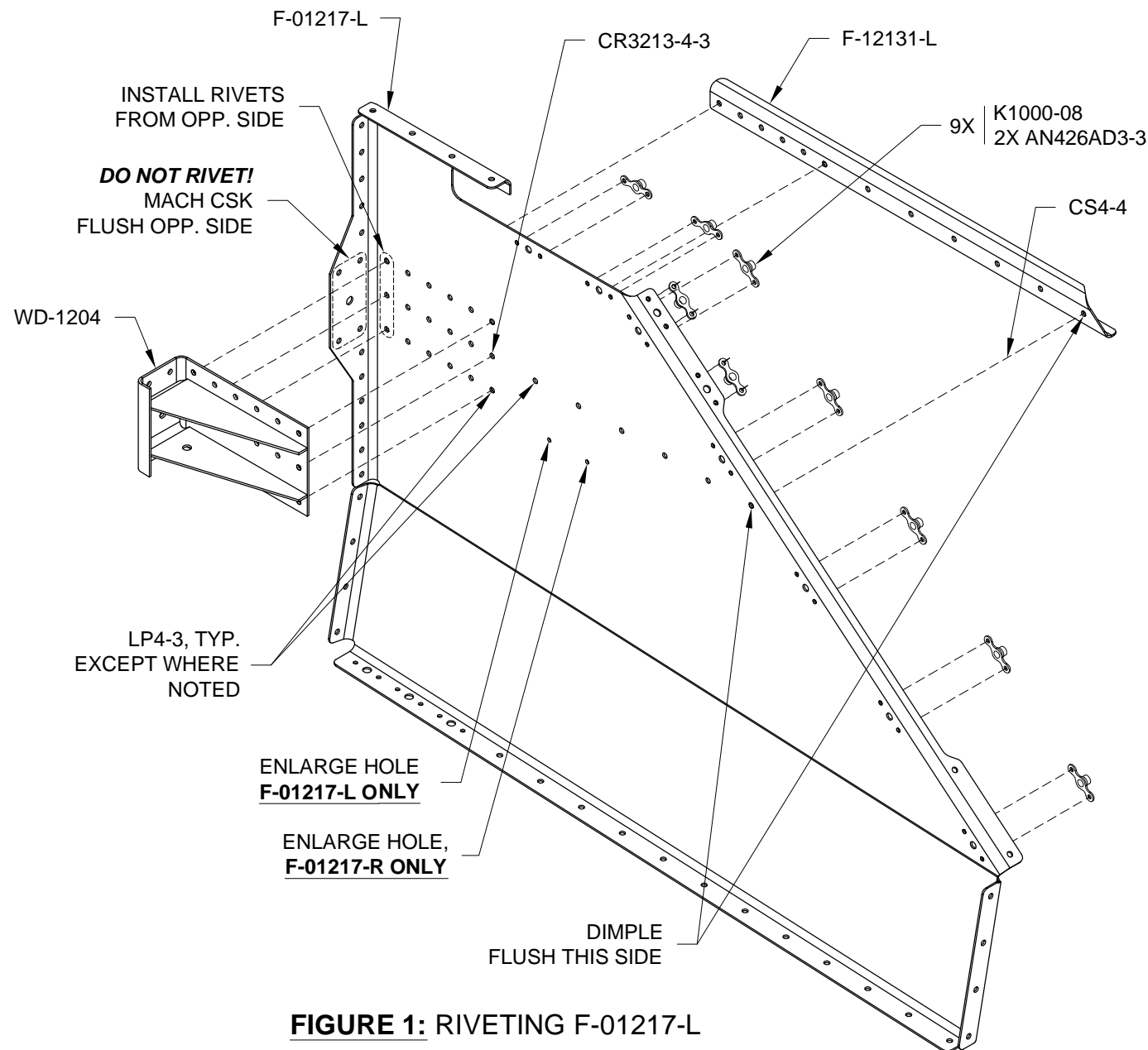

**FIGURE 1: RIVETING F-01217-L**

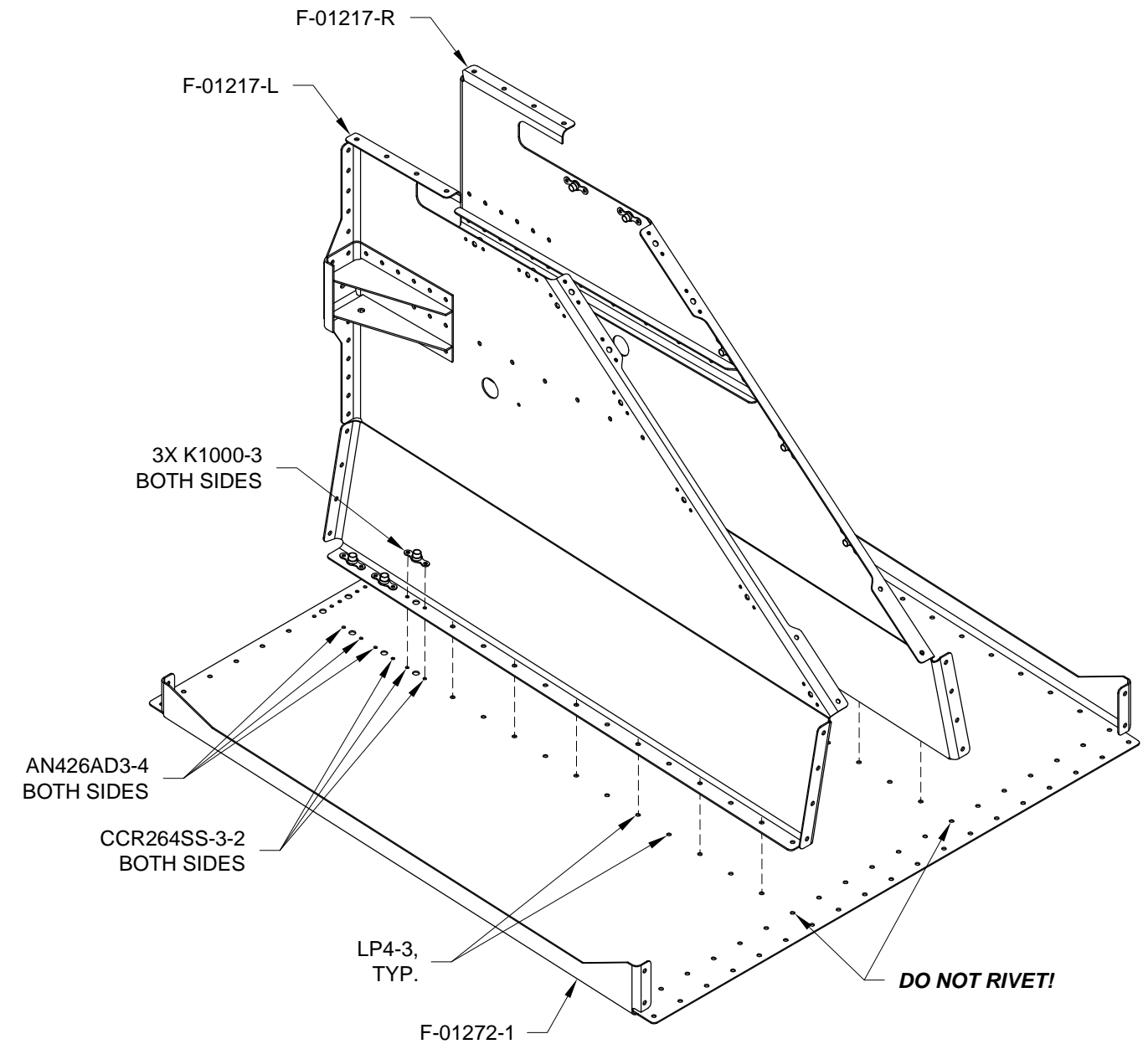

**FIGURE 2: RIVETING F-01217-L & -R & F-01272-1**

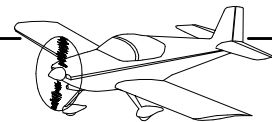

**Step 1:** Scuff the bend radii around the aft side of the firewall perimeter. Also scuff the top flange (see "Apply Tank Sealant" call-out in Figure 2). Scuff the mating skins then clean all of the parts to provide good adhesion for a future fillet of sealant to be placed at their junction.

**Step 2:** Cleco together F-01201C-1, F-01217-L & -R, F-01272-1 as shown in Figure 1.

**Step 3:** Rivet together F-01201C-1, F-01217-L & -R, and F-01272-1 using the hardware as shown in Figure 2.

Rivet the seven nutplates to the bottom flange of F-01201C-1 and the fwd edge of F-01272-1 per the callouts in Figure 2.

**Step 4:** Smear a thin layer of fuel tank sealant on the top surface of the top flange of the F-01201C-1.

Cleco then rivet F-01201B-1 and all F-01257-1 per the Figure 2 call-outs.

**Step 5:** Place a fillet of sealant along the inside corner formed by the firewall and bottom skin in between the F-01217-L & -R. See Figure 1.

**Step 6:** Cleco FF-01204D-L-1 & -R-1 and FF-00088A & B to F-01201C-1 per Figure 2 callouts.

**Step 7:** Machine countersink the holes in FF-00089 for the flush screws called out in Figure 2.

**Step 8:** Attach FF-00089 as shown in Figure 2. Insert the called out screws, bushings, and hardware to check for fit. Final-Drill #19 if/as required. If drilled, remove, clear chips, and reinstall.

**Step 9:** Rivet FF-00088A & B and FF-01204D-L-1 & -R-1 to F-01201C-1 per the call-outs.

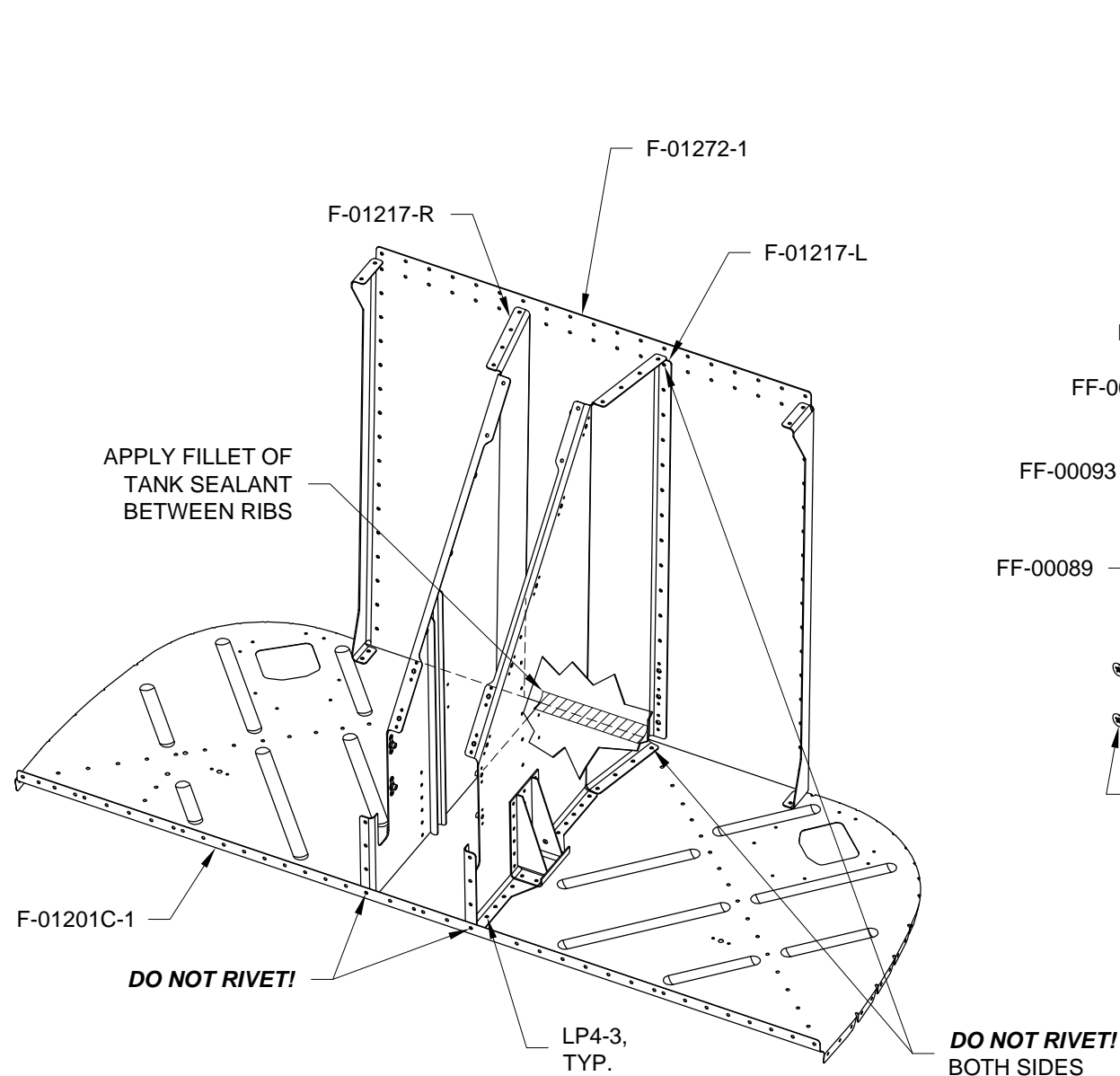

**FIGURE 1: FWD LOWER FUSE ASSEMBLY**

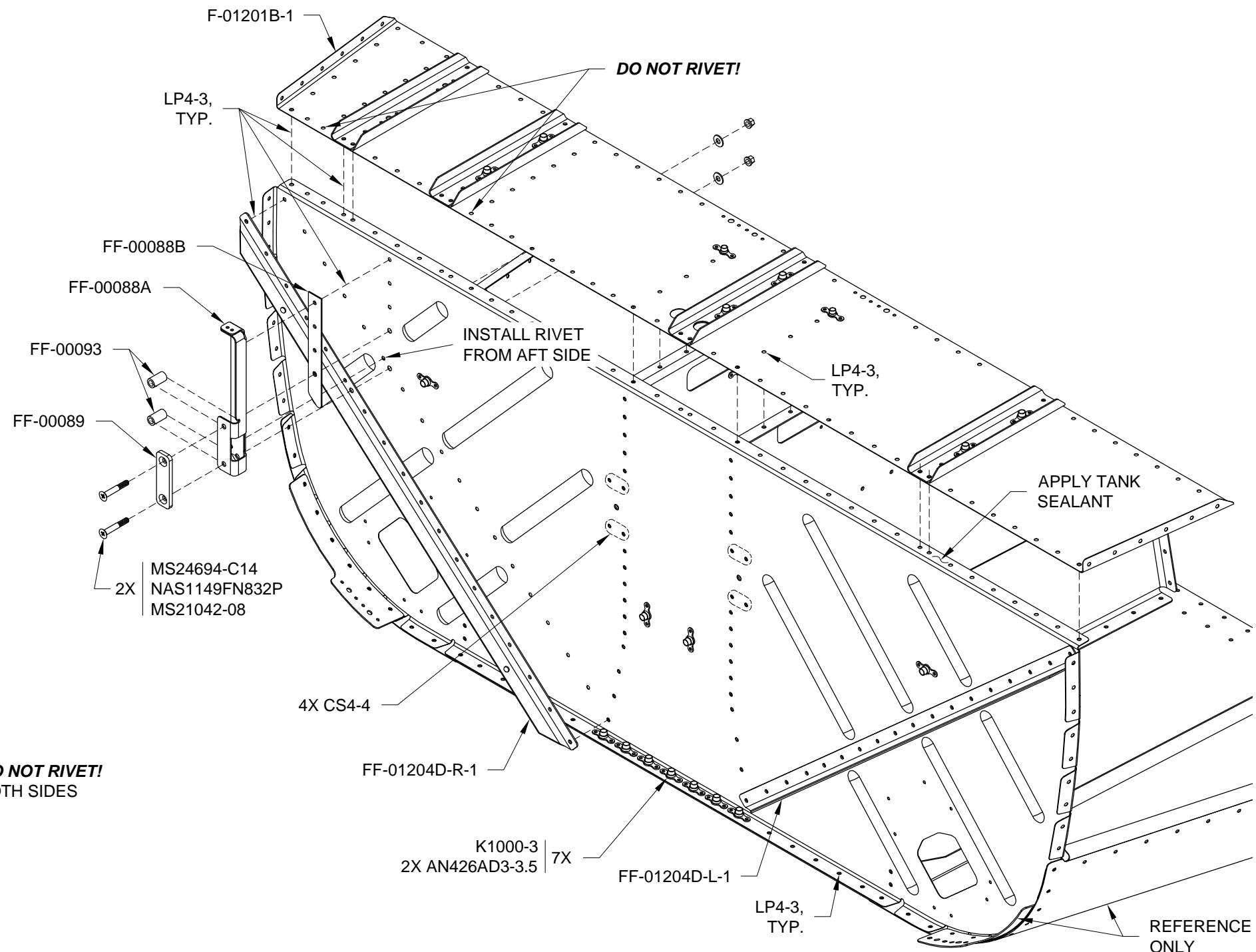

**FIGURE 2: ATTACHING SHELF & STIFFENERS**

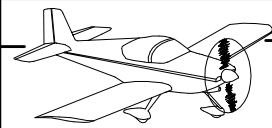

Step 1: Cleco then rivet F-1271-L & -R as shown in Figure 1.

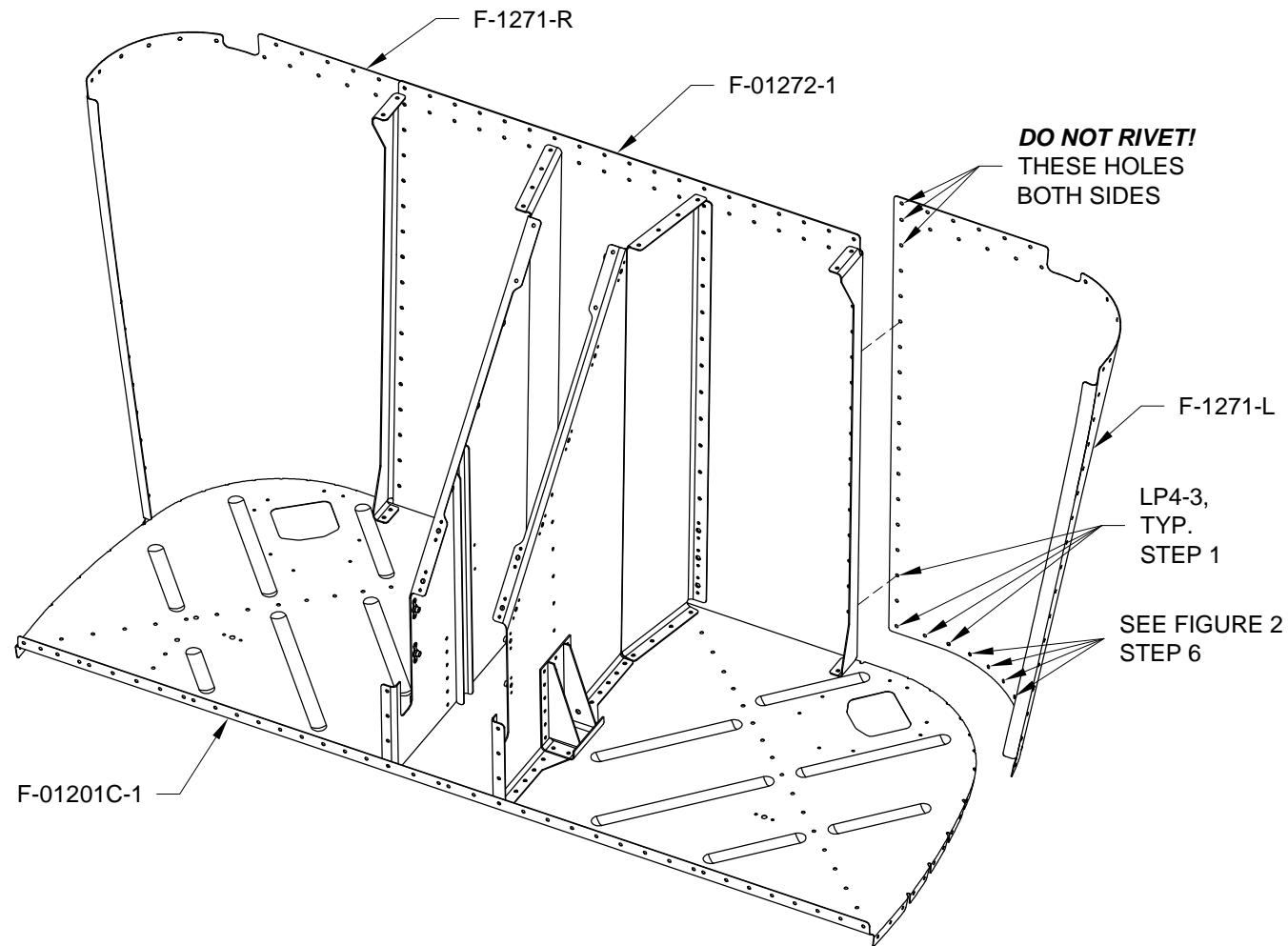

**FIGURE 1: ATTACHING F-1271-L & -R**  
(SOME PARTS OMITTED FOR CLARITY)

Step 2: Bend the left side F-12130A and F-12130B by hand to match the curvature of the lower firewall flange then cleco them in place at the #30 hole. See Figure 2 detail view.

Step 3: Final-Drill #30 the #40 holes in F-12130A-L and F-12130B-L using the F-01201C-1 flange and F-1271-L as a guide. Remove and deburr.

Step 4: Rivet F-12130A-L and F-12130B-L as shown in Figure 2 detail view.

Step 5: Repeat Steps 2-4 for the right side. Also see Page 22iS/U-05 Figure 2 for a completed installation.

These parts are now the Fwd Lower Fuselage Assembly.

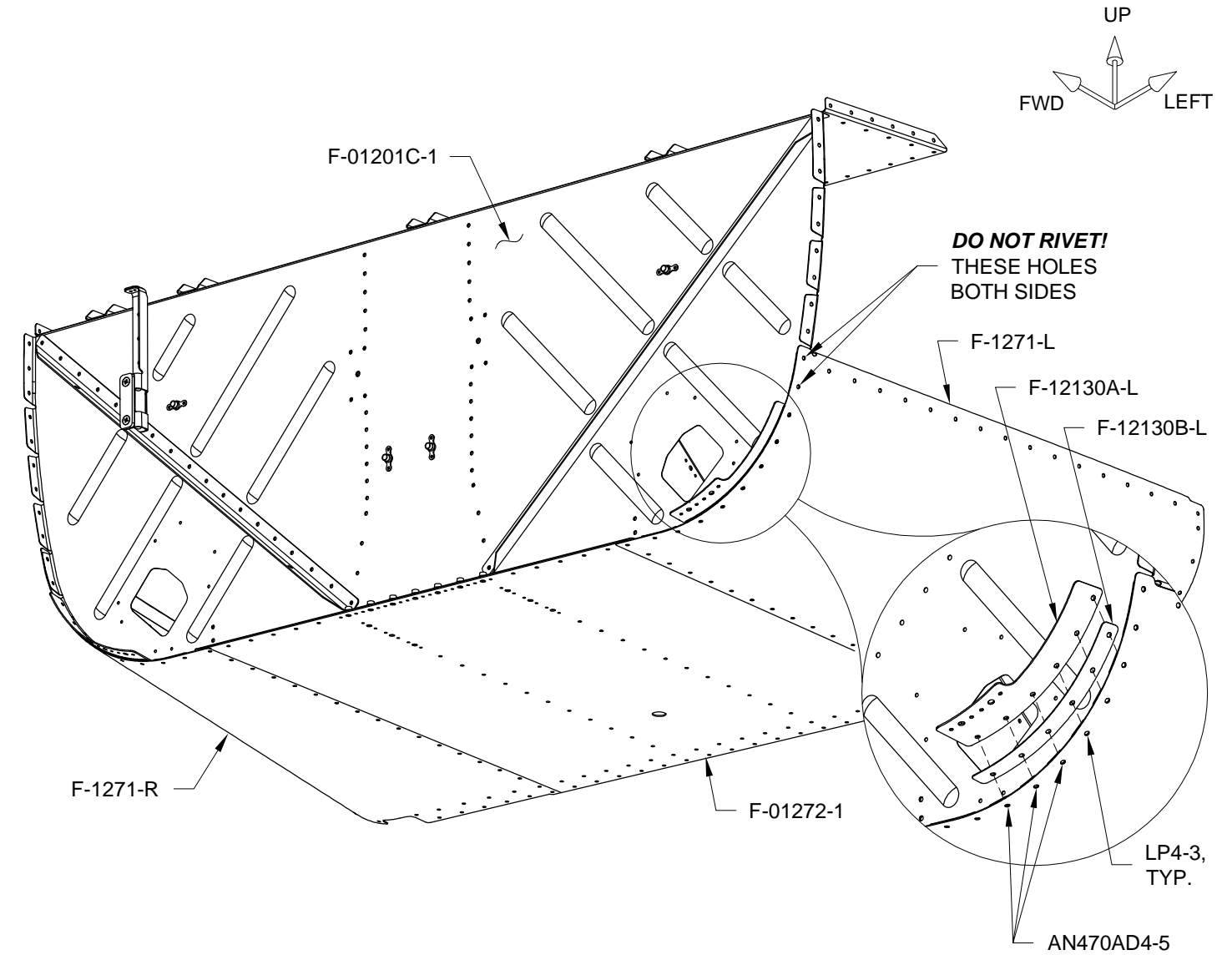

**FIGURE 2: INSTALLING COWL ATTACH PLATES**  
(BOTTOM ISOMETRIC VIEW)

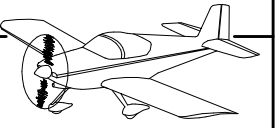

Step 1: Cleco then rivet the Fwd Lower Fuse Assembly to the Fuselage as shown in Figures 1 and 2.  
The skins from the Fwd Lower Fuse Assembly lie over (outside) of the skins on the Fuselage.

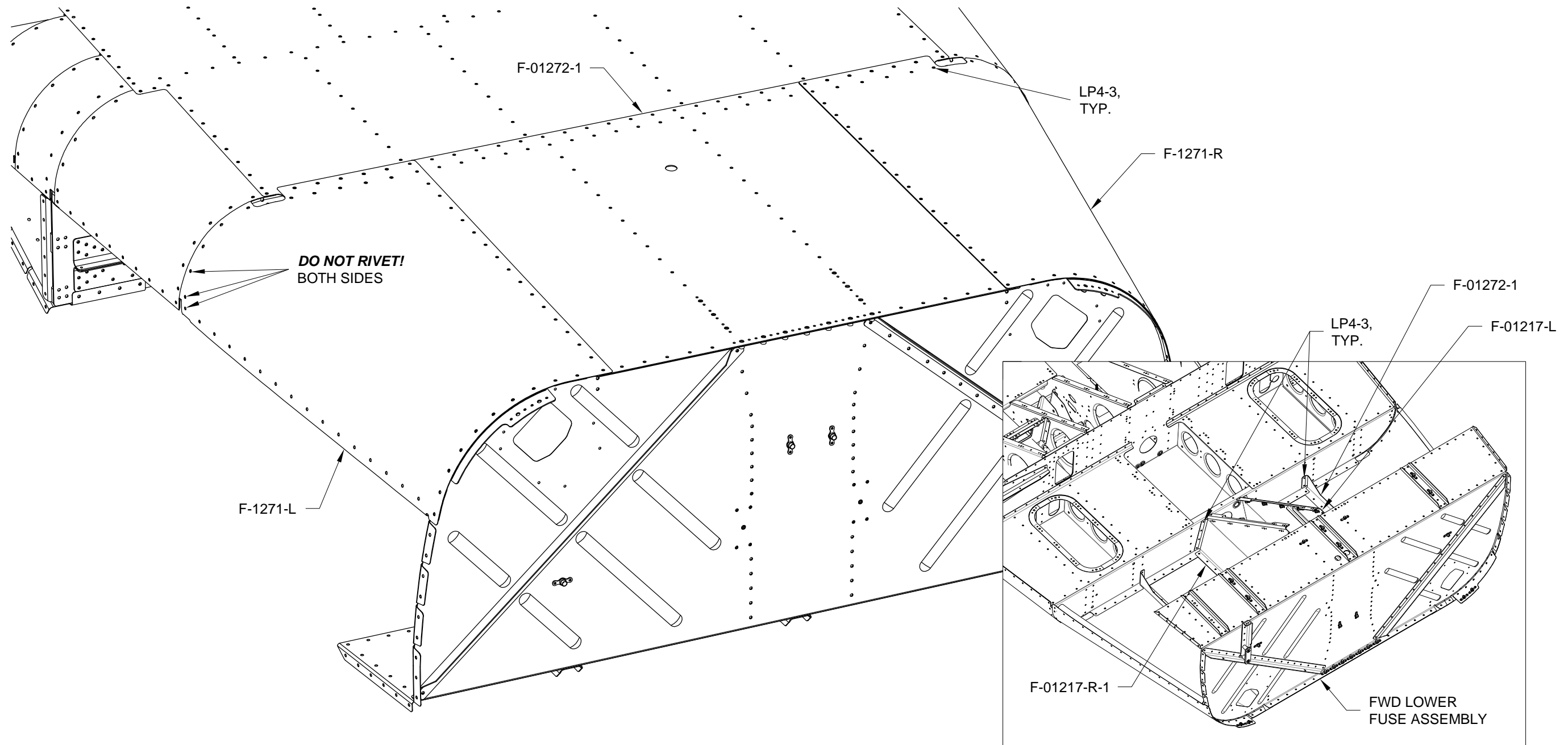

**FIGURE 1:** ATTACHING THE FWD LOWER FUSE ASSEMBLY

**FIGURE 2:** ATTACHING THE AFT FLANGES OF THE TUNNEL & FWD BOTTOM SKIN



**THIS PAGE INTENTIONALLY LEFT BLANK**