

SECTION 24iS/U: ROLLOVER STRUCTURE & F-01207 BULKHEAD

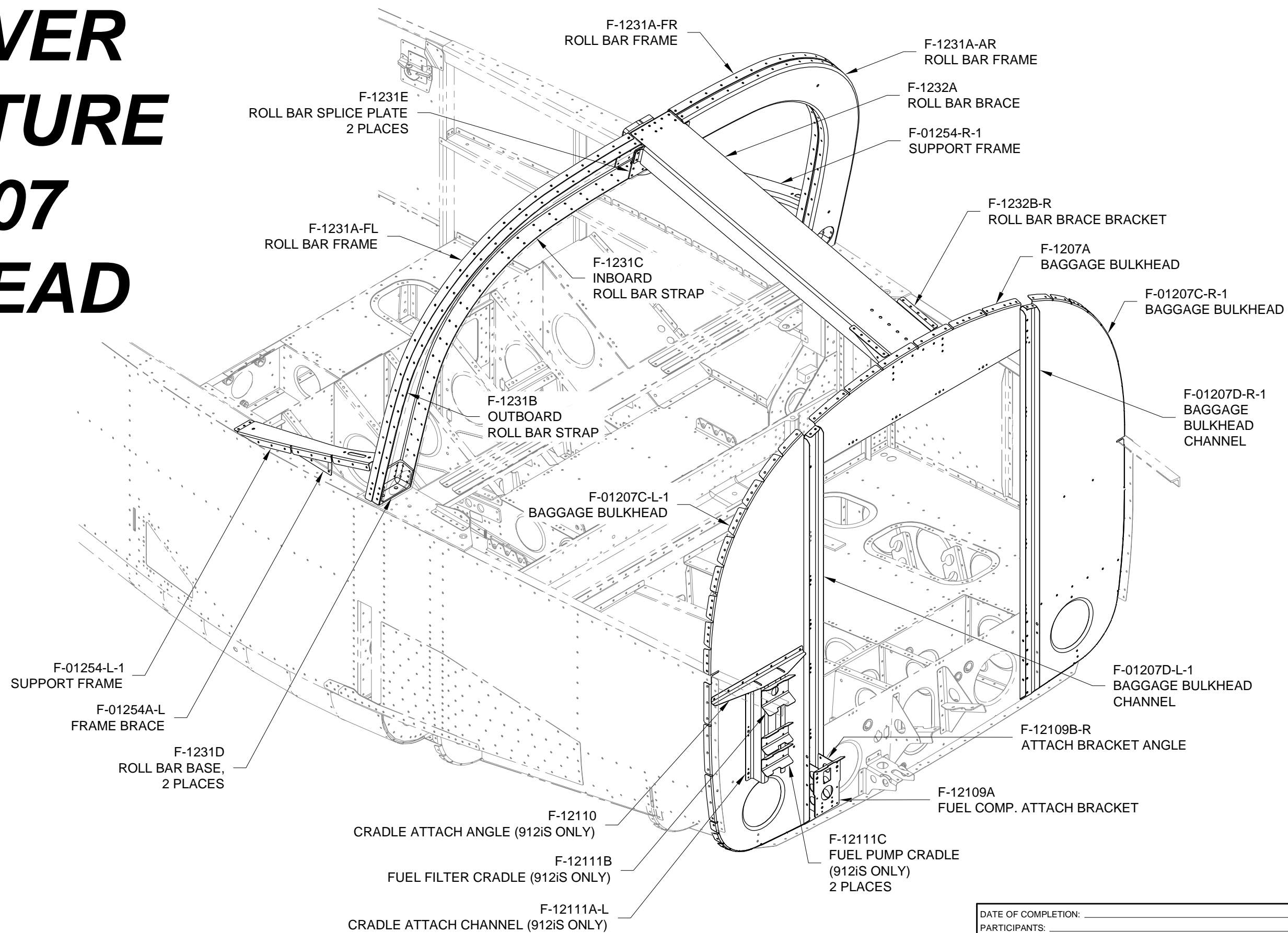

DATE OF COMPLETION: _____			
PARTICIPANTS: _____			
DATE: 09/18/17	REVISION: 0	RV-12iS	PAGE: 24iS/U-01



Step 1: Study Figure 2 to determine the forward edge, top, and bottom of the F-1231B & C, the ends are beveled to accommodate the tilt of the roll bar. Run the F-1231B & C back and forth over the edge of a table to add a curvature to the parts. Be careful not to let the parts kink across the rivet holes. The curve

does not have to be the final installed shape but enough to allow easy assembly of the roll bar. Deburr the edges of all parts used to create the Roll Bar Assembly. Cleco all of the parts of the Roll Bar Assembly together as shown in Figure 2.

If the clecos are too short to go through the C-01213B, the C-01213A can be clecoed directly to the F-1231A-FR & FL for the purpose of match-drilling the holes in Step 6.

Step 2: Break the edges of the F-1231D Roll Bar Bases with a file, than apply a film of *BoeLube* to the outside faces and edges of the F-1231D's as shown in Figure 1.

Step 3: Bolt the F-1231D's to the F-01205B-L-1 & -R-1 as shown in Figure 1. Tighten just enough to hold the F-1231Ds flat, but allow some movement and adjustment.

Step 4: Cleco the Roll Bar Assembly to the forward face of the F-1231D's as shown in Figure 1. With a mallet, tap the forward face of the roll bar assembly near the clecos to ensure the Roll Bar Assembly is fully seated against the F-1231D's.

NOTE: During Step 5, start from the center and move outward, putting a cleco in each hole as drilling progresses. Avoid trapped chips between parts as much as possible.

Step 5: Final-Drill #30 all #40 holes in the flanges of the F-1231A-FL, -FR, -AL & -AR and F-1231B & C.

Step 6: Match-Drill #30 the three holes of the C-01213A through the F-1231A-FR & -FL and underlying F-1231E. See the detailed view of Figure 2.

Step 7: Disassemble and deburr the roll bar parts.

Step 8: Except for the holes common to the F-1231D's pointed out in Figure 1, machine countersink the **outer flanges** of the F-1231A-FL, -FR, -AL and -AR for the heads of the rivets that will eventually lay underneath the canopy.

Step 9: Machine countersink the C-01213A for the heads of the rivets called out in the detail view of Figure 2.

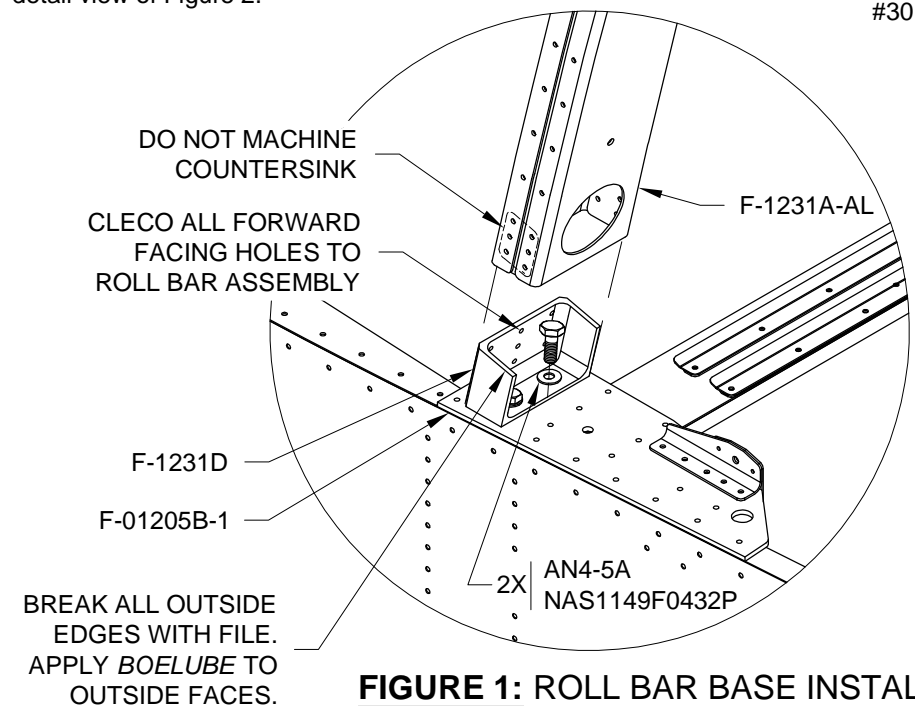

**FIGURE 1: ROLL BAR BASE INSTALL
LEFT SHOWN, MIRROR FOR RIGHT**

Step 10: Machine countersink the five holes on the forward face of the F-1231A-FL & -FR indicated in the detailed view of Figure 2.

Step 11: Cleco the F-01231F-2 to the F-1231A-AR and aft F-1231E. Match-Drill #43 the switch mounting hole of the F-01231F-2 into the F-1231A-AR and F-1231E. See the detail view in Figure 2.

Step 12: Remove the F-01231F-2. Final-Drill #30 the hole just created in the F-1231A-AR and F-1231E only.

Step 13: Deburr the F-01231F-2 and tap #4-40 the switch mounting hole in the F-01231F-2 only.

Step 14: Cleco the roll bar assembly back together, then cleco it to the F-1231D's using the forward facing holes. This will hold position while riveting the Roll Bar Assembly.

CAUTION: Do not rivet the locations marked with a triangle in Figure 2 until later in the assembly process!

Step 15: Rivet the F-1231E's and F-01231F-2 to the F-1231A-FL, -FR, -AL, & -AR per the call-outs in Figure 2, then rivet in place the C-01213A and C-01213B.

Step 16: Rivet along the flanges of the Roll Bar Assembly, start at the center and move outwards. Periodically check for flatness across the forward face of the Roll Bar Assembly and adjust as required.

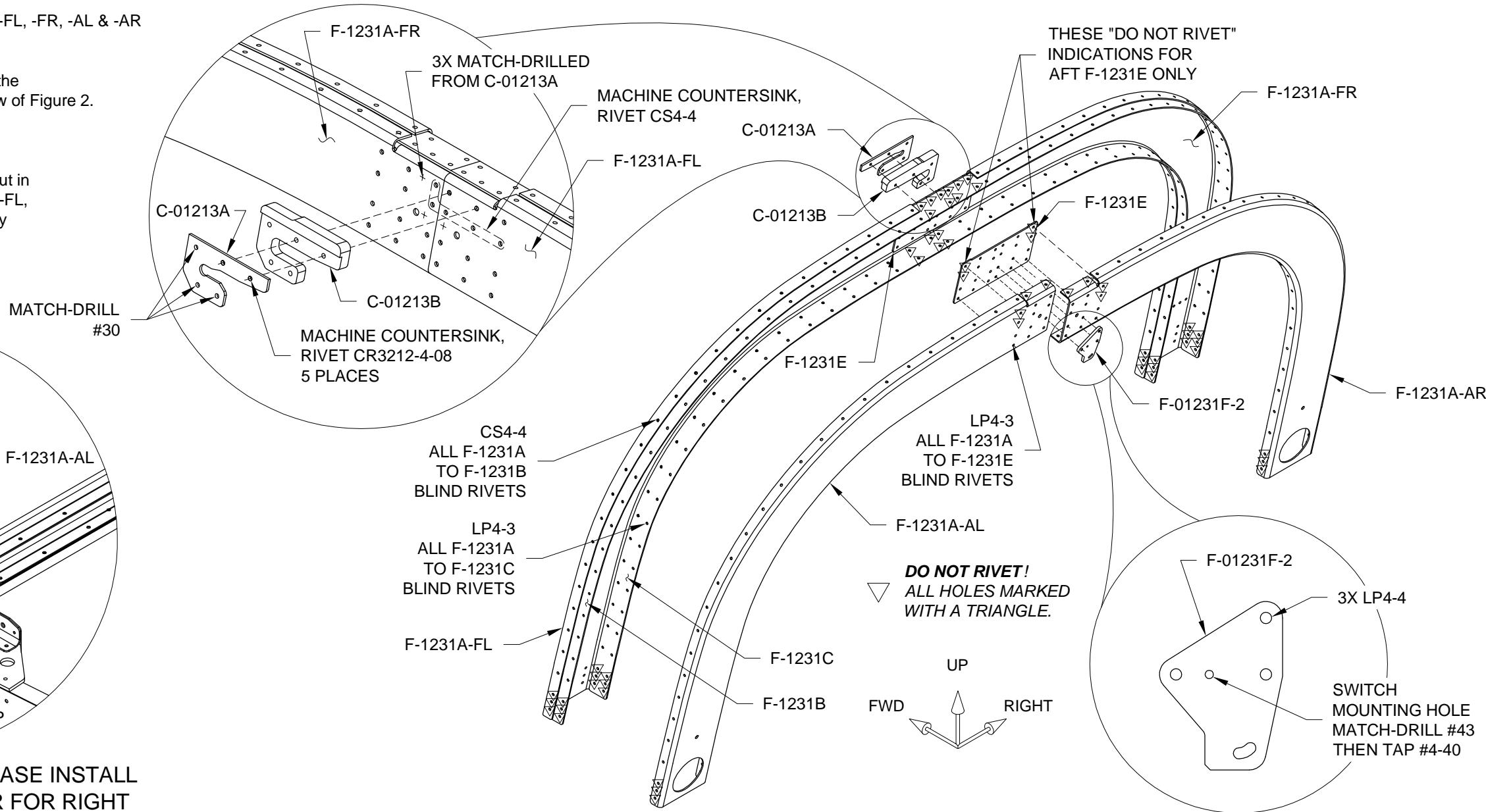

FIGURE 2: ROLL BAR ASSEMBLY



Step 1: Cleco the C-01205A Canopy Block Drill Template onto the bottom of the Roll Bar Assembly as shown in Figure 1.

Step 2: Match-Drill #30 the indicated hole of the C-01205A into the Roll Bar Assembly. Be sure to drill perpendicular to the surface. Remove the C-01205A and deburr the hole.

Step 3: Machine countersink and then rivet the three holes in the Roll Bar Assembly for the flush head rivets called-out in Figure 1.

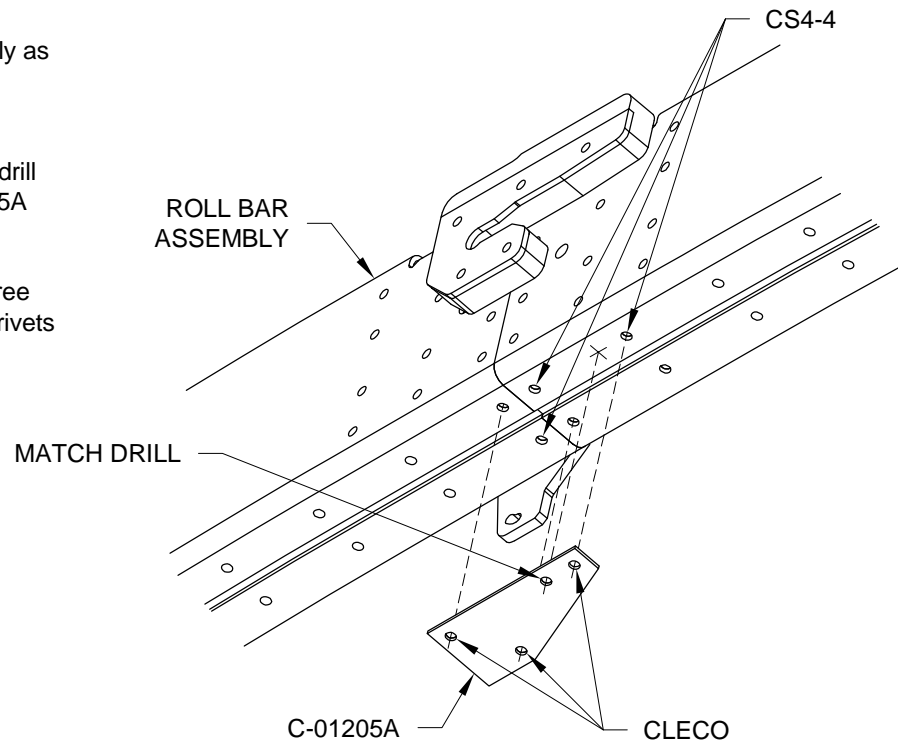

FIGURE 1: DRILLING FOR THE CANOPY LATCH BLOCK

Step 4: Tap #8-32 the three holes in the Roll Bar Assembly for the screws shown in Figure 2. The C-01205-2 can be used to help keep the tap square to the bottom surface of the Roll Bar assembly: Insert the tap through one of the two holes in the thicker portion of the C-01205-2, center the end of the tap on the hole in the Roll Bar Assembly, slide and hold the C-01205-2 flush against the bottom of the Roll Bar Assembly, then tap the hole. Repeat for the remaining two holes.

Step 5: Install the dome head rivet in the hole indicated in Figure 2

Step 6: Machine countersink the C-01205-2 for the heads of the screws, then install it with the hardware shown in Figure 2. Do not install the two C-01205B's. They are installed in Section 34iS/U for adjustment of the canopy, if necessary, and are shown here for reference purposes only.

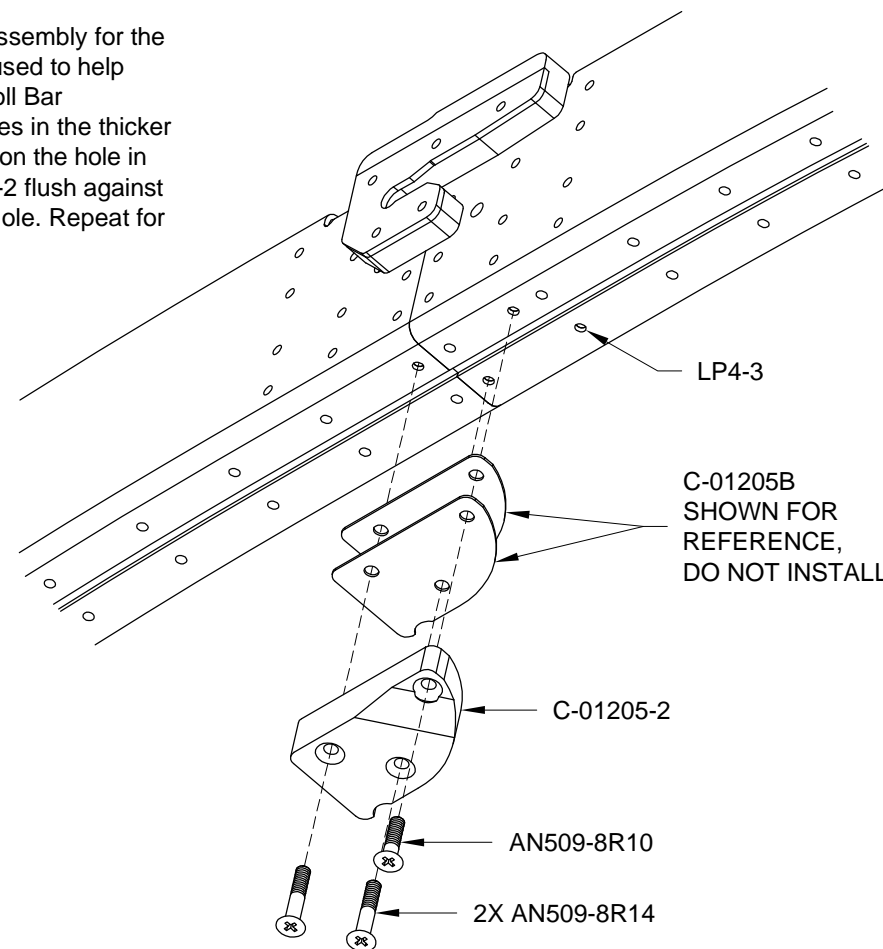

FIGURE 2: C-01205B-2 INSTALL

Step 7: Remove the hatched areas shown in Figure 3 to separate the F-1232B into left and right parts.

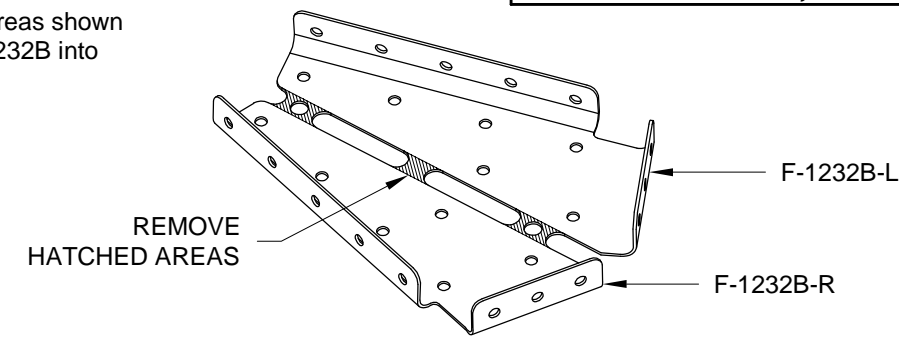

FIGURE 3: SEPARATING THE F-1232B

Step 8: Remove the hatched areas shown in Figure 4 from the flanges of both the F-01254-L-1 & -R-1.

Step 9: Drill #17, deburr, and dimple both holes indicated in Figure 4 for the head of a #8 screw.

Step 10: Dimple the three #30 holes on the forward end for flush blind rivets.

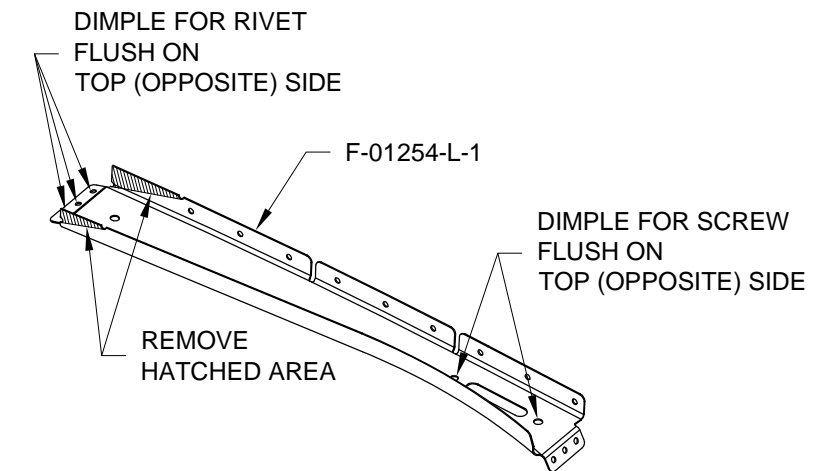

FIGURE 4: TRIMMING THE F-01254-L-1 & -R-1

Step 11: Separate the F-01254A into left and right parts by removing the hatched areas shown in Figure 5.

Step 12: For a better fit when riveted, lightly break the top edge of F-01254A-L & -R in the same direction as the flange at the end of the parts. See Figure 6.

Step 13: Deburr, cleco, then rivet the F-01254A-R onto the F-01254-R-1 as shown in Figure 6 to create the Roll Bar Support Assembly. Mirror for the left side.

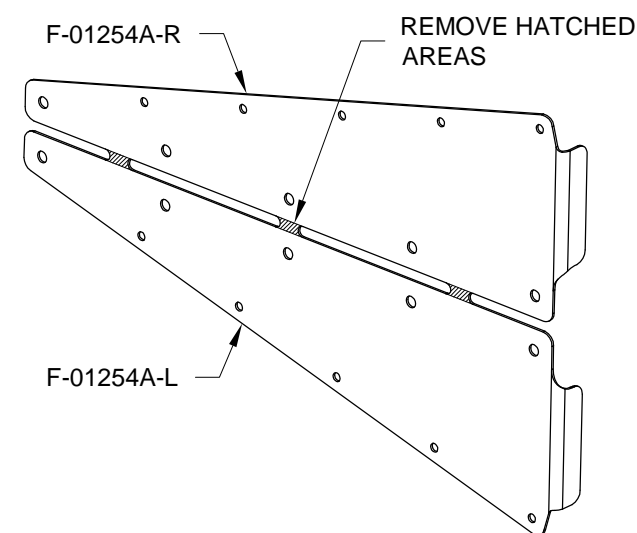

FIGURE 5: SEPARATING THE F-01254A

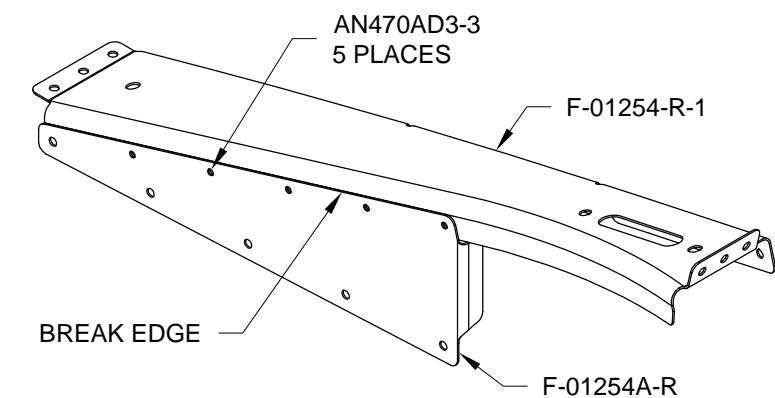

FIGURE 6: ROLL BAR SUPPORT ASSEMBLY



Step 1: With the Roll Bar Assembly clecoed to the forward face of the F-1231D's, cleco the Roll Bar Support Assemblies to the Roll Bar Assembly and F-01234-L-1 & -R-1 as shown in Figure 1. Again, use a mallet to ensure the Roll Bar Assembly is seated against the forward face of the F-1231D's.

Step 2: Match-Drill #30 the twelve holes in the sides of the Roll Bar Assembly into the F-1231D's.

Step 3: Remove, deburr, prime, and loosely reattach the F-1231D's to the F-01205B-L-1 & -R-1.

Step 4: Cleco, then rivet the Roll Bar Assembly to the F-1231D's per the call-outs in Figure 1.

Step 5: Rivet the Roll Bar Support Assemblies to the Roll Bar Assembly and to the F-01234-L-1 & -R-1 as shown in Figure 1.

Step 6: Tighten the bolts securing the F-1231D's.

Step 7 (912iS Only): Final-Drill #19 the two indicated holes in the aft flange of the F-01224-L-1 Baggage Floor. These two holes correspond to the two holes final-drilled in the F-01207C-L-1 on the next page.

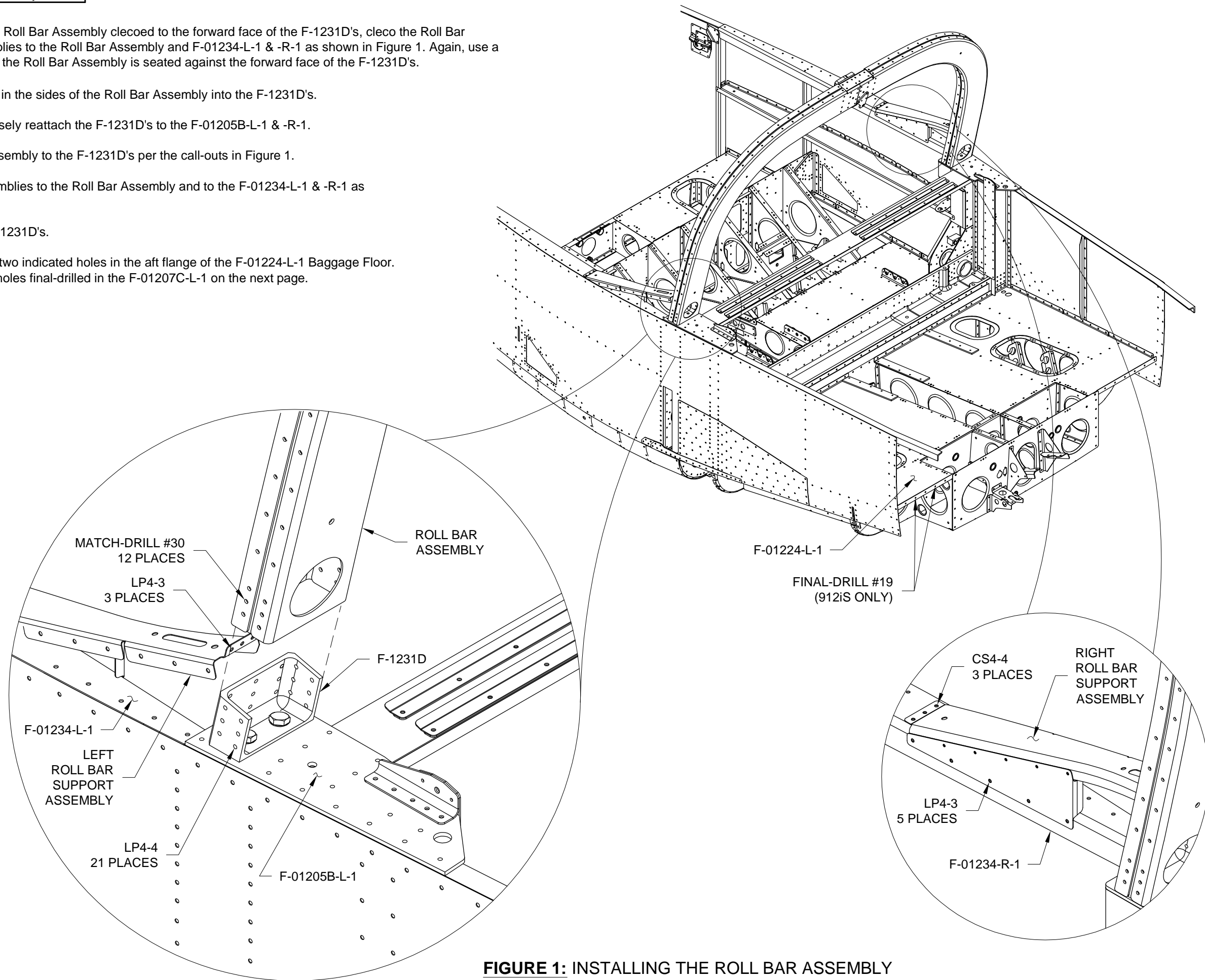
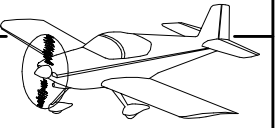

FIGURE 1: INSTALLING THE ROLL BAR ASSEMBLY



Step 1: Mark a line on the forward face of the F-1284-L & -R as dimensioned in the Detail View of Figure 1.

Step 2: Cleco the F-01207C-L-1 & -R-1 to the Tailcone Assembly as shown in Figure 1.

Step 3: Center the lines drawn in Step 1 in the two indicated holes in the F-01207C-L-1 & -R-1, then clamp in place and match-drill #30 from the F-01207C-L-1 & -R-1 into the corresponding F-1284-L & -R. See Figure 1. Remove the clecos and deburr the holes.

Step 4: Rivet the ES-00301 onto the F-01207C-L-1 using the hardware called out in Figure 1.

Step 5 (912iS Only): Final-Drill #19 the two holes in the F-01207C-L-1 as indicated in the detail view of Figure 1.

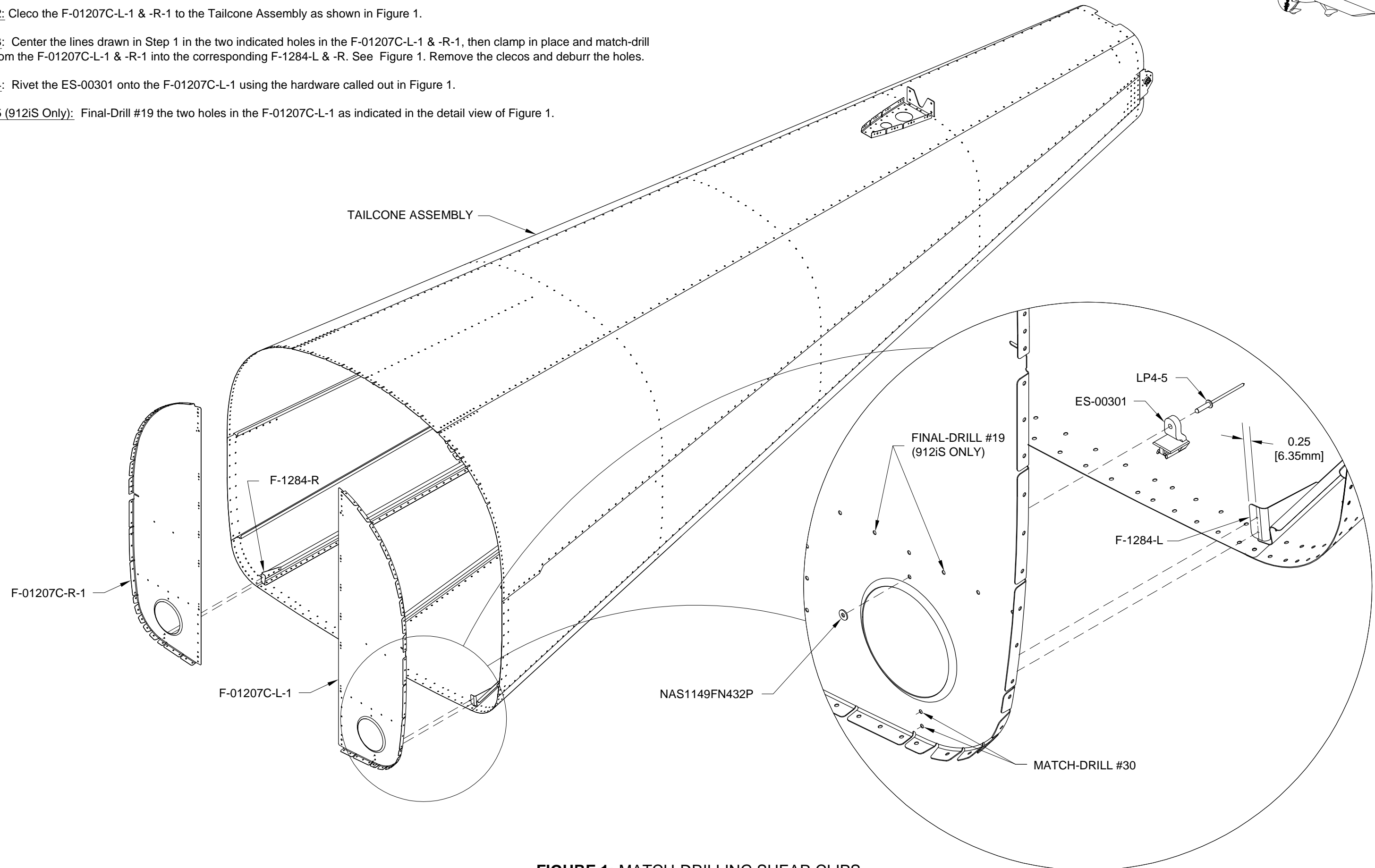
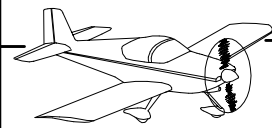

FIGURE 1: MATCH-DRILLING SHEAR CLIPS



NOTE: Steps 1 through 12 apply to Rotax 912iS equipped aircraft only. If building a 912ULS equipped aircraft, fill the two holes in the F-012107C-L-1 with the rivets called out in Figure 1, and proceed to the NOTE before Step 13.

Step 1: Cleco the F-12110 to the aft face of the F-01207C-L-1 using the two holes shown in Figure 1.

Step 2: Match-Drill #30 the five remaining holes in the F-12110 into the F-01207C-L-1.

Step 3: Remove the F-12110 from the F-01207C-L-1 and deburr.

Step 4: Rivet the F-12110 to the F-01207C-L-1 as directed in Figure 1.

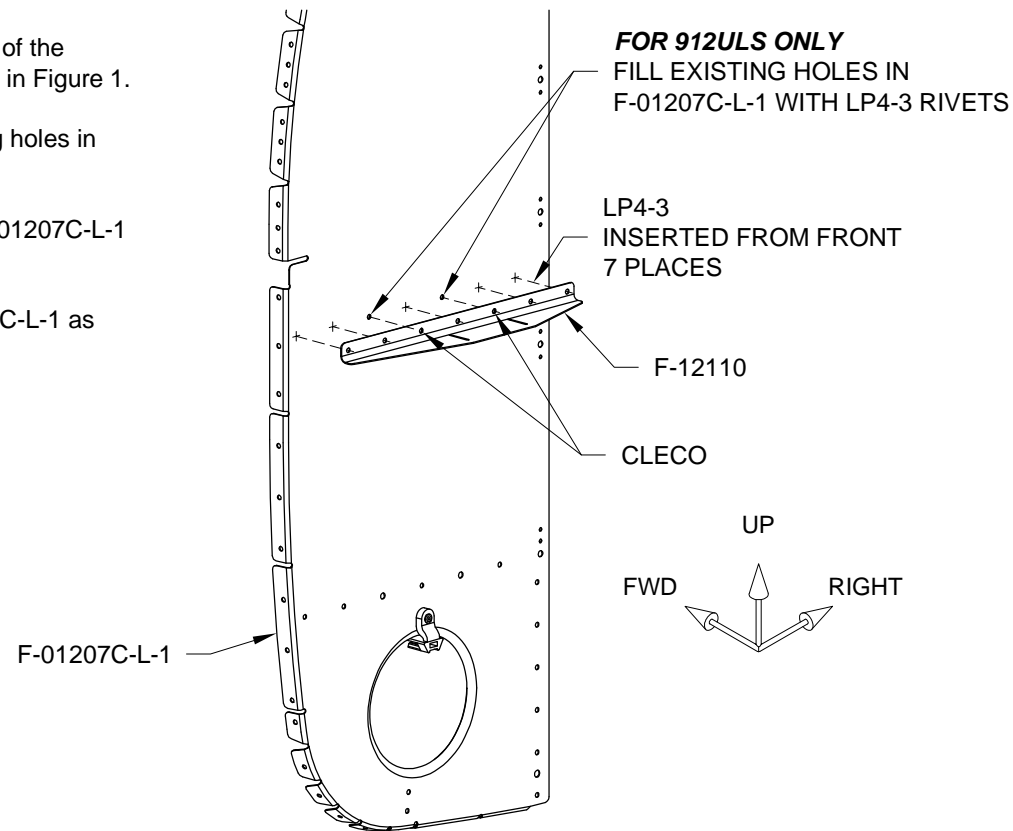

FIGURE 1: ATTACHING THE F-12110

Step 5: Dimple the nutplate attachment holes in the F-12111A-L & -R for flush rivets on the forward side of the flange.

Step 6: Separate the F-12111C into two individual parts, then machine countersink for the rivets called out in Figure 2.

Step 7: Rivet the two F-12111C's and then the F-12111B to the F-12111A-L & -R as shown in Figure 2 to create the Fuel Pump Bracket Assembly.

Step 8: Rivet only the bottom nutplates to the F-12111A-L & -R as shown in Figure 2.

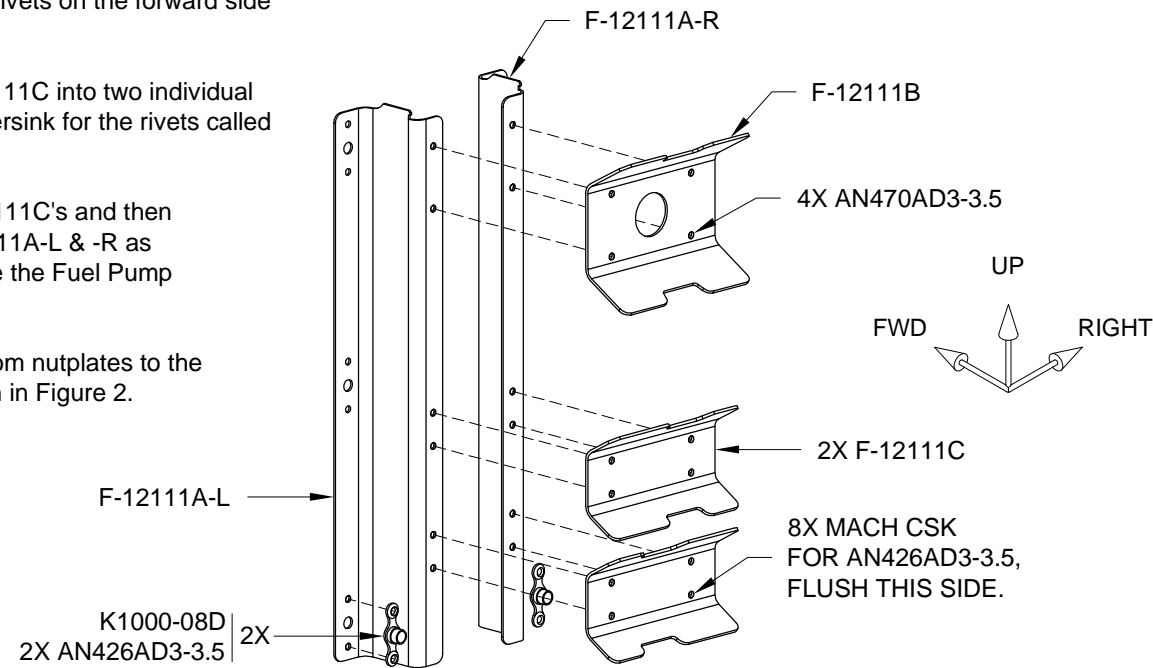

FIGURE 2: FUEL PUMP BRACKET ASSEMBLY

Step 9: Insert the tabs at the top of the Fuel Pump Bracket Assembly into the slots in the F-12110, and secure the bottom of the Fuel Pump Bracket Assembly to the F-1207C-L-1 using #8-32 screws. See Figure 3.

Step 10: Match-Drill the four remaining nutplate screw holes in the flanges of the Fuel Pump Bracket Assembly into the F-01207C-L-1 as indicated in Figure 3.

Step 11: Remove the Fuel Pump Assembly Bracket from the F-01207C-L-1 and deburr the match-drilled holes.

Step 12: Rivet the nutplates called out in Figure 3 to the flanges of the Fuel Pump Bracket Assembly.

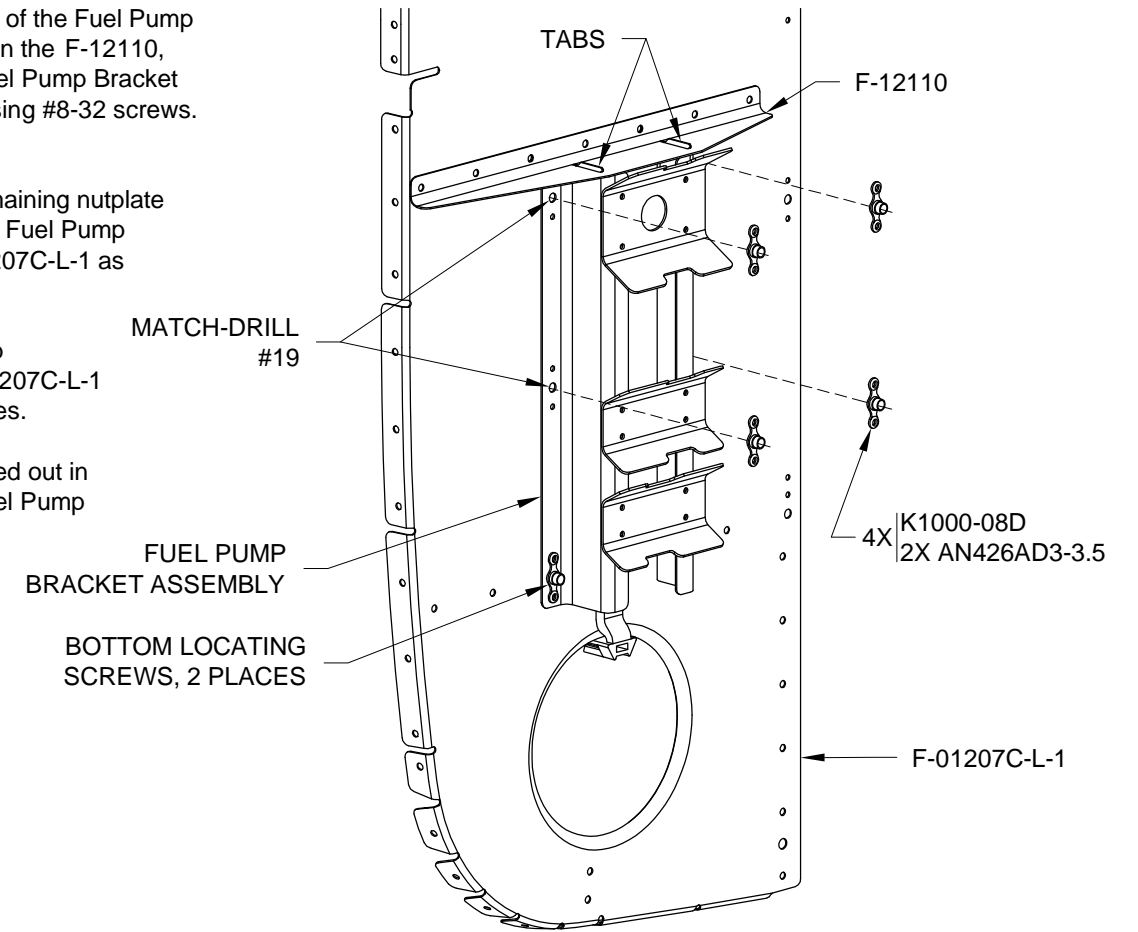

FIGURE 3: MATCH-DRILLING THE F-01207C-L-1

Step 13: Fill the two indicated holes in the F-01207C-R-1 with the rivets called out in Figure 4. Place the manufactured head on the forward side.

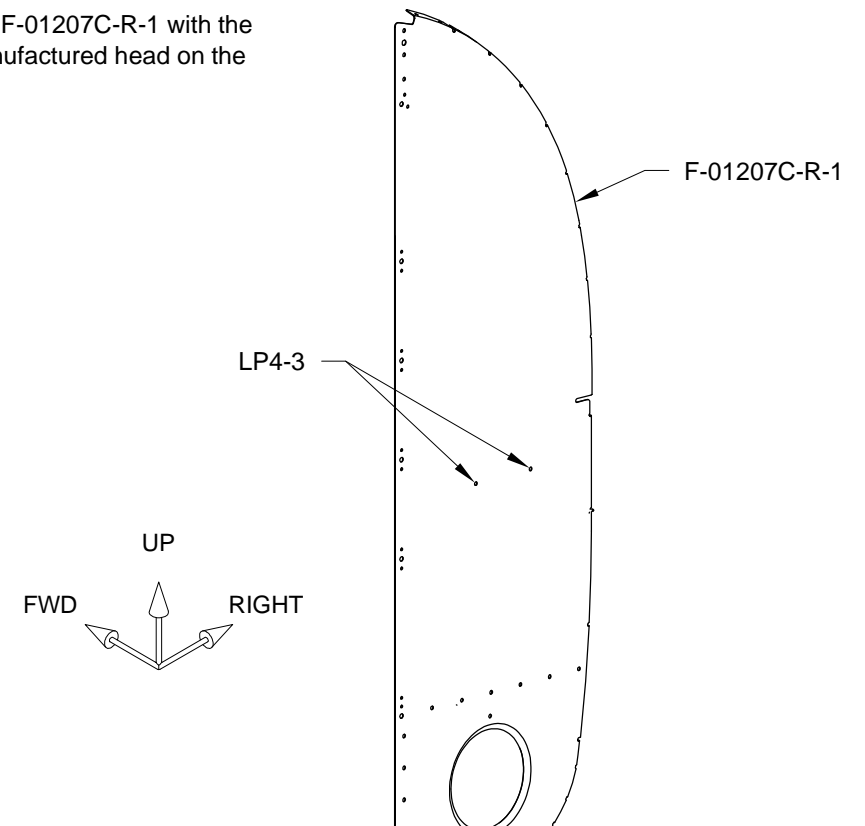
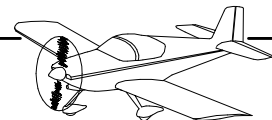

FIGURE 4: F-01207C-R-1 RIVETS



CAUTION: Do not rivet any parts to the fuselage skins in this section!

Step 1: Dimple the nutplate rivet holes (flush forward side) in the F-1207A, F-01207C-L-1 & -R-1, and F-01207D-L-1 & -R-1. See Figure 1.

Step 2: Flute the F-01207C-L-1 & -R-1 along the three long flanges below the longeron cutout to align the holes in the flanges with the holes in the F-01270-L-1 & -R-1.

Step 3: Dimple the nutplates shown in Figure 1 that are not already dimpled.

Step 4: Cleco then rivet: the nutplates, F-1207A, F-01207C-L-1 & -R-1, F-01207D-L-1 & -R-1, F-01207B-1, and F-01224-L-1 & -R-1 as shown in Figure 1. Note that the F-01207C-L-1 & -R-1 are positioned **forward** of the overlapping F-01207B-1 as shown in Figure 1.

Step 5: Cleco, then rivet the F-1232B-L & -R to the F-1232A.

Step 6: Cleco the F-1232A to the Roll Bar Assembly, and the F-1232B-L & -R to the F-1207A.

Step 7: Machine countersink the upper face of the F-1232A for the flush rivets that attach to the Roll Bar Assembly as called out in Figure 1.

Step 8: Rivet the F-1232A to the Roll Bar Assembly and the F-1232B-L & -R to the F-1207A per the call-outs in Figure 1.

Step 9 (912iS Only): Reattach the Fuel Pump Bracket Assembly to the F-01207C-L-1 using the screws called out in Figure 1.

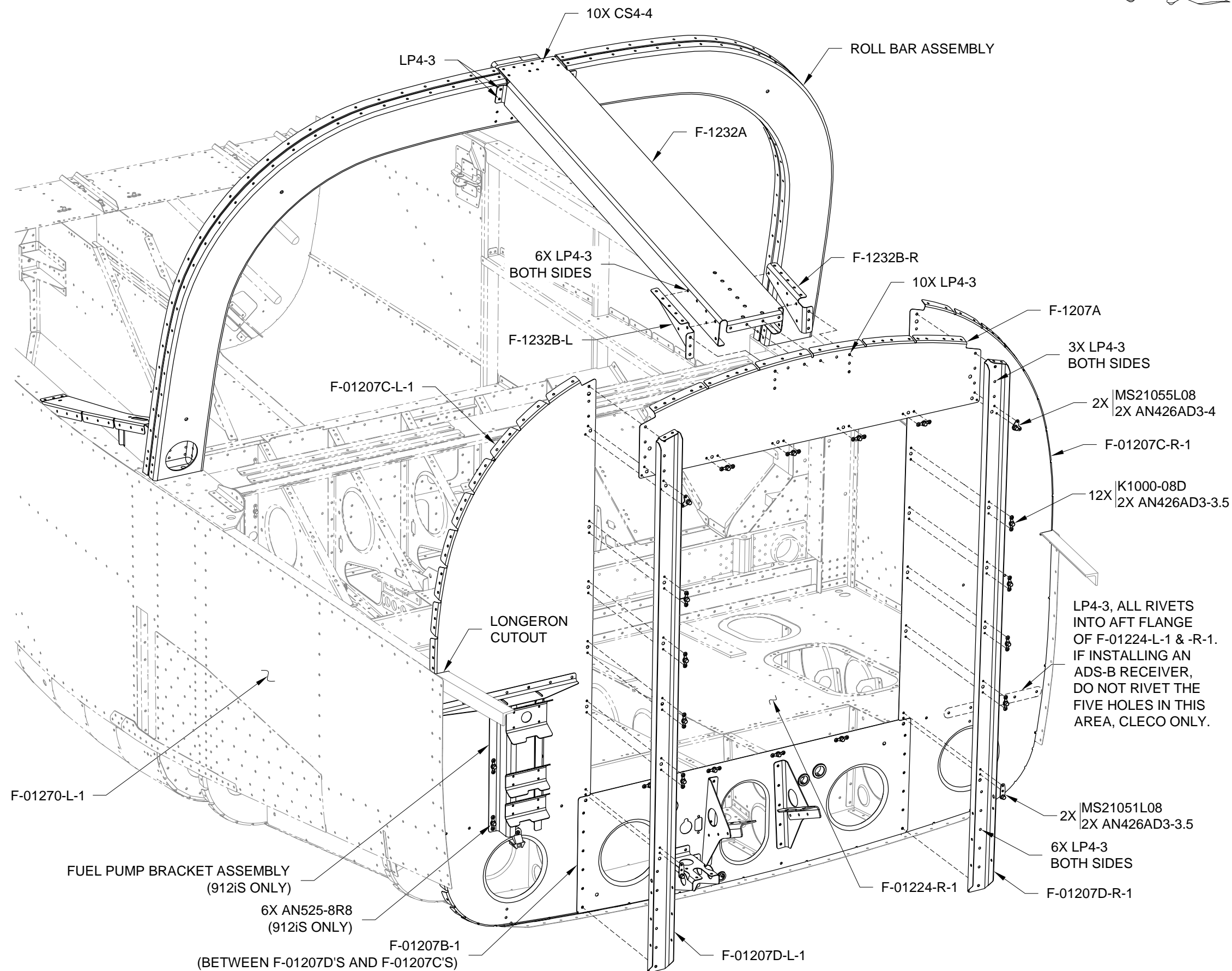

FIGURE 1: F-01207 BULKHEAD ASSEMBLY



Step 1: Machine countersink the rivet holes in the F-012109A as indicated in Figure 1.

Step 2: Rivet the lower two nutplates onto the F-12109A as shown in Figure 1.

Step 3: Rivet the top two nutplates and the F-12109B-L & -R onto the F-12109A as shown in Figure 1 to create the F-12109.

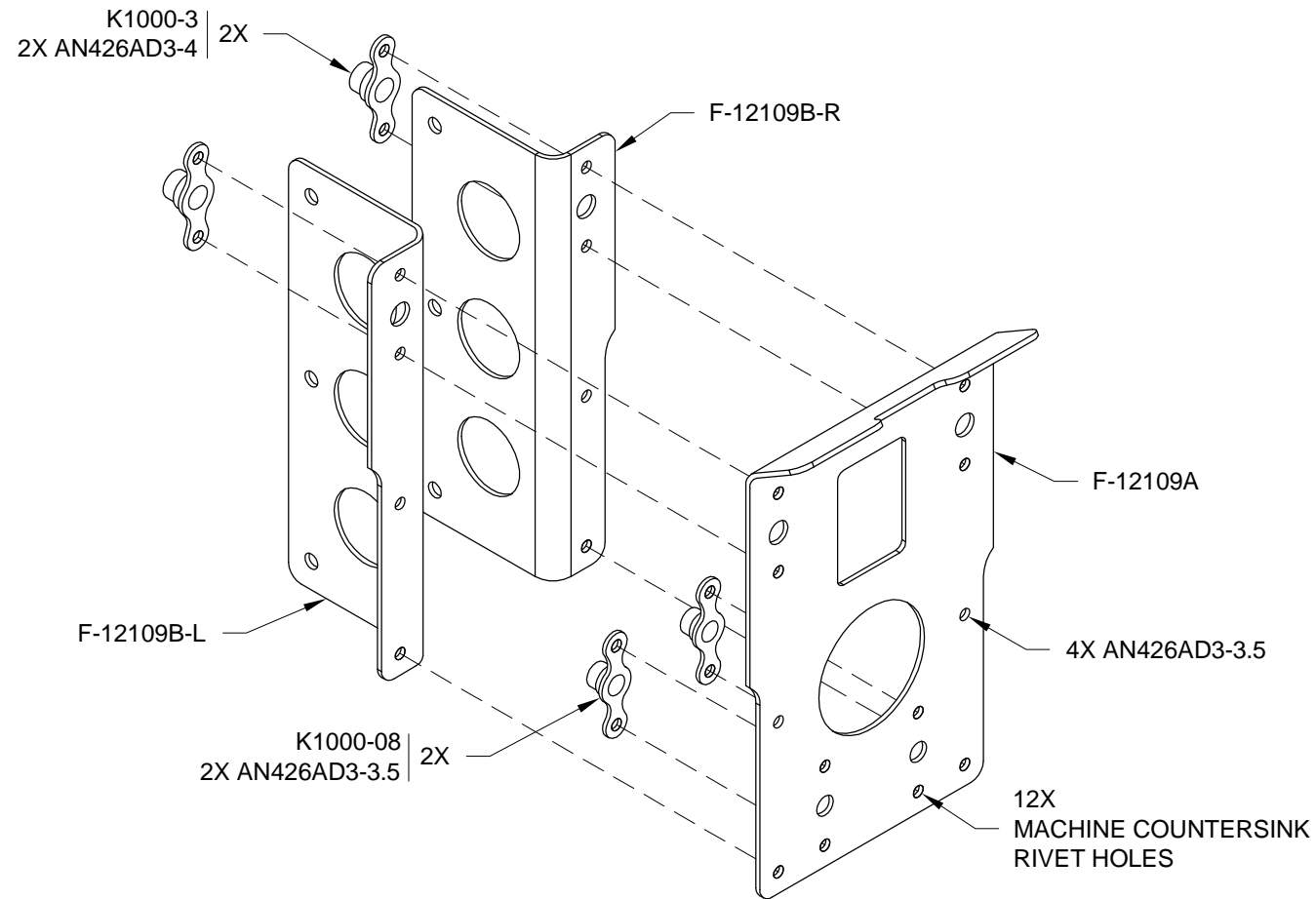

FIGURE 1: RIVETING THE F-12109 ASSEMBLY

Step 4: Rivet the F-12109 to the F-01207D-L-1 as shown in Figure 2.

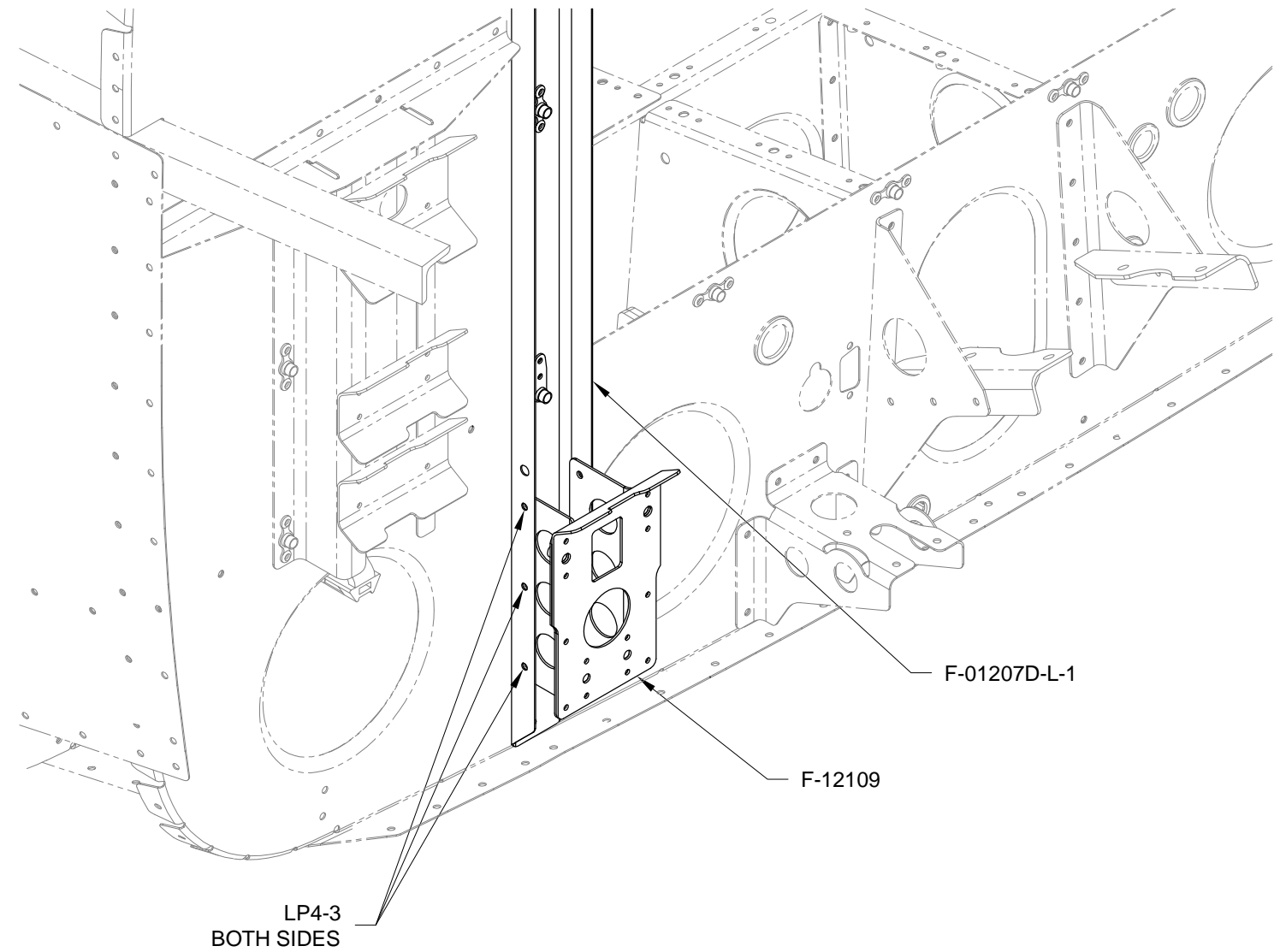

FIGURE 2: F-12109 ASSEMBLY INSTALLATION