

SECTION 25A: PLEXIGLAS AFT WINDOW

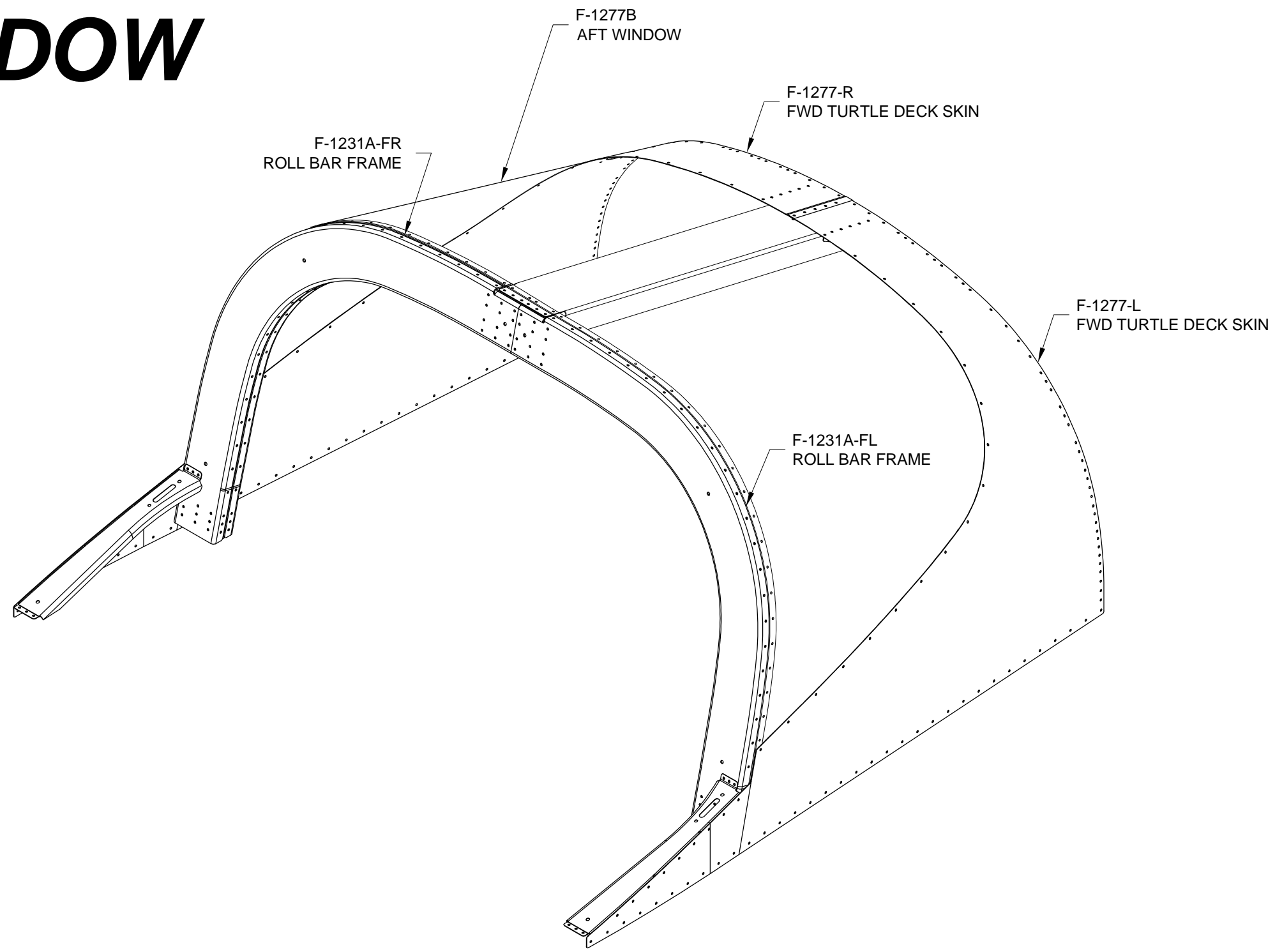

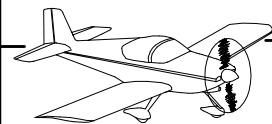

NOTE: Review Section 5.19 before proceeding.

Step 1: Cleco and rivet the F-1277-L & -R Fwd Turtle Deck Skins to the Fuselage and Tailcone Assemblies and to themselves as shown in Figure 1.

Step 2: Position the F-1277B Aft Window on the fuselage as shown in Figure 1.

Slide the window underneath the F-1277-L & -R Fwd Turtle Deck Skins and aft against the F-1232B-L & -R Roll Bar Brace Brackets.

Step 3: Adjust the lateral (left/right) position of the F-1277B Aft Window as required to obtain the most consistent overlap between the aft edge of the window and the forward edge of the F-1277-L & -R Fwd Turtle Deck Skins.

Step 4: Push the lower forward edges of the F-1277B Aft Window aft in order to force the window outward against the F-1277-L & -R Fwd Turtle Deck Skins and to reduce any gaps.

Step 5: Securely clamp the F-1277B Aft Window to Roll Bar with spring clamps.

Place additional spring clamps along the roll bar so that the "nose" of each clamp butts against the forward edge of the window: this will prevent the window from shifting forward.

Step 6: Mark the inside of the F-1277B Aft Window where it contacts the F-1232B-L & -R Roll Bar Brace Brackets with a permanent marker. Material will be removed from the window to accommodate the brackets.

Step 7: Examine the entire roll bar and record the shortest distance between the forward edge of the F-1277B Aft Window and the aft edge of the F-1231A-FL & -FR Roll Bar Frames.

Step 8: Remove the F-1277B Aft Window.

NOTE: As supplied, the F-1277B Aft Window is protected by plastic film. To maintain this protection during the construction process, leave most of the plastic film in place until the aircraft is nearly ready to fly.

Step 9: Remove the F-1277B Aft Window. Peel back and trim the protective plastic on the inside and outside of the window to approximately 1 in. [25.4 mm] from the edge of the window.

NOTE: To prevent cracking, each window attach hole must have at least 5/16 in. [7.9 mm] of edge distance.

Step 10: Remove material from the F-1277B Aft Window to accommodate the F-1232B-L & -R Roll Bar Brace Brackets using the length determined in Step 7.

Step 11: Repeat Steps 2 through 5 to verify proper fit. The F-1277B Aft Window must not contact the F-1232B-L & -R Roll Bar Brace Brackets.

Step 12: Round any sharp corners within the modified areas.

Step 13: Repeat Steps 2 through 5.

NOTE: The adhesive used on some brands of electrical tape may be incompatible with the F-1277B Aft Window. Test the tape on a scrap of material before use. In all cases, do not leave the tape on the aft window for extended periods of time (more than two days).

Step 14: Apply a line of quality tape (masking or electrical) to the outside of the F-1277B Aft Window. Offset the aft edge of the tape 1/16 inch from the upper/forward edge of the F-1277-L & -R Fwd Turtle Deck Skins.

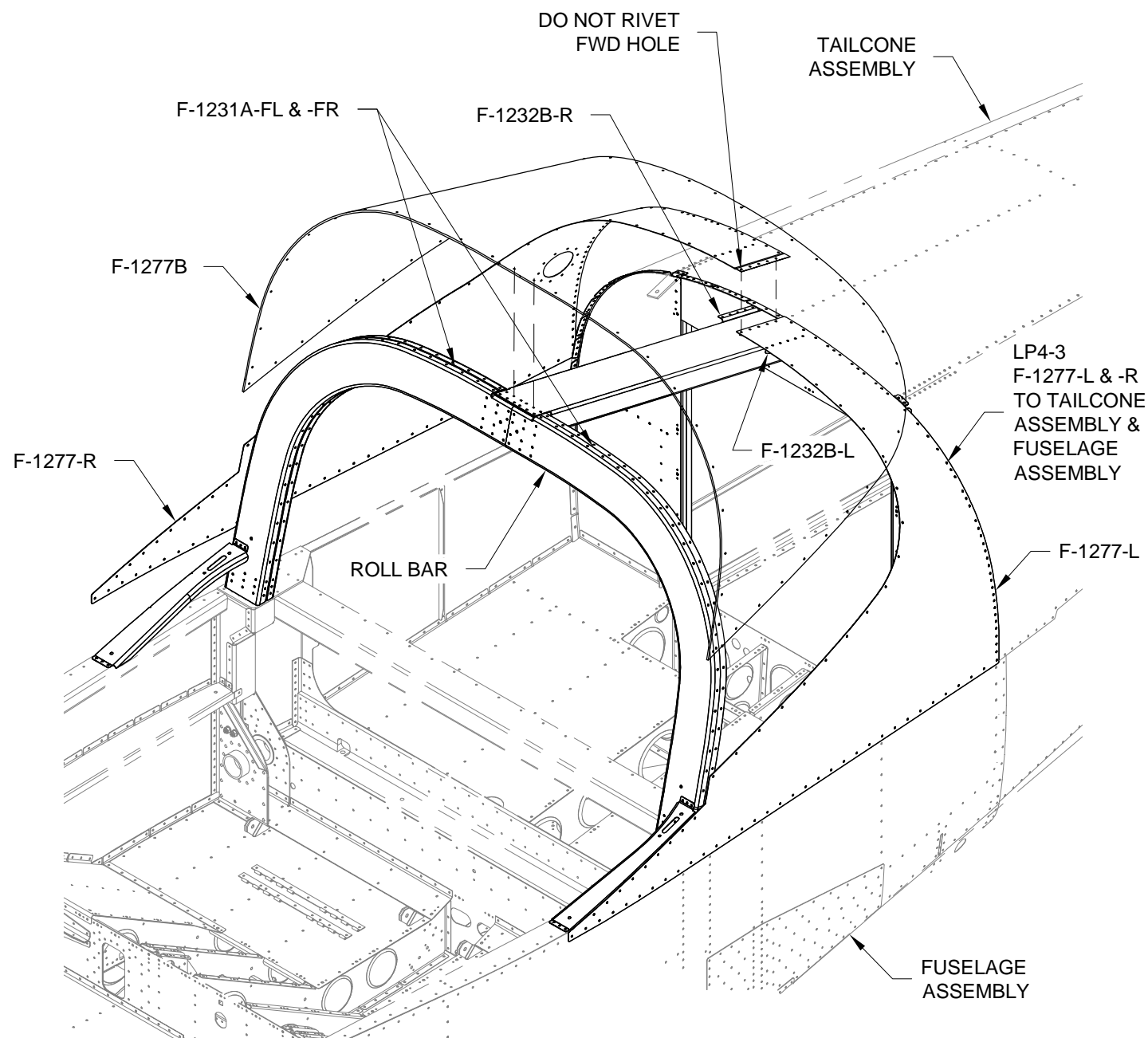

FIGURE 1: TURTLE DECK INSTALLATION AND AFT WINDOW FIT



NOTE: When drilling the F-1277B Aft Window, be aware of visual distortion due to parallax. Always drill perpendicular to the surface of the window. After drilling each hole, remove any drilling debris that becomes trapped between the parts being drilled.

NOTE: Have a helper position a wood back-up block underneath each hole as it is match-drilled. This will help to keep the window tight against the skins, prevent chipping around the drill exit hole, and greatly reduce the risk of cracks.

Step 1: Drill and match-drill the F-1277B Aft Window and associated structure:

Drill the groups of holes in the order shown in Figure 1 (1 through 10). Start on the left side at the inboard-most hole in each group and then drill its mirror on the right side. Proceed symmetrically and outboard one hole at a time. Cleco each hole as it is drilled. Verify proper window fit after drilling each hole.

(a) Match-Drill #30 the holes in the F-1277-L & -R Fwd Turtle Deck Skins into the F-1277B Aft Window.

(b) Drill #40 the F-1277B Aft Window and F-1231A-AL & -AR Roll Bar Frames. Evenly space each hole midway between the rivets in the roll bar.

(c) Match-Drill #40 the forward-most hole in group 10. Center the bit on the #30 hole in each F-1277-L & -R Fwd Turtle Deck Skin.

Step 2: Final-Drill #36 and tap 6-32 all of the holes common to the F-1231A-AL & -AR Roll Bar Frames and F-1277B Aft Window. Both the roll bar frames and the aft window are tapped. Use the drilling order/method described in the previous step ("3", "5", "7", "9", and the forward hole in "10").

Install a screw in each hole as it is tapped. Use low torque to minimize stress on the window. See the hardware called out in Figure 2 on the next page.

Step 3: Remove every other screw from the F-1231A-AL & -AR Roll Bar Frames.

Step 4: Apply a line of quality tape (masking or electrical) to the outside of the F-1277B Aft Window. Align the forward edge of the tape with the aft edge of the F-1231A-FL & -FR Roll Bar Frames. Create a cutout in the tape for each screw head. See Figure 2.

This tape marks the final trim line at the forward edge of the window.

Step 5: Remove the F-1277B Aft Window.

Step 6: Final-Drill #27 the remaining #30 holes in the F-1277B Aft Window. Position a wood back-up block underneath each hole as it is drilled.

Step 7: Trim the forward edge of the F-1277B Aft Window up to the line of tape that was applied in Step 4. Remove the line of tape.

Step 8: Chamfer the top and bottom edges of the F-1277B Aft Window as shown in the detail view of Figure 1.

Step 9: Use fine-grit sandpaper to remove all visible scratches from the trimmed and chamfered edges of the F-1277B Aft Window.

Step 10: Break the edges of the F-1277-L & -R Fwd Turtle Deck Skins inward so that they will fit tightly against the F-1277B Aft Window.

Step 11: Final-Drill #27 the window attach holes in the F-1277-L & -R Fwd Turtle Deck Skins.

NOTE: Now is a good time to paint the aircraft interior if/as desired.

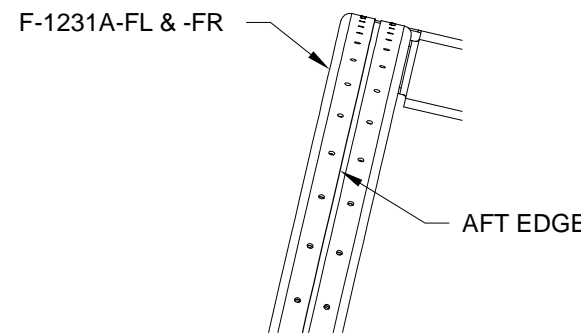

FIGURE 2:
AFT EDGE OF FWD ROLL BAR FRAMES

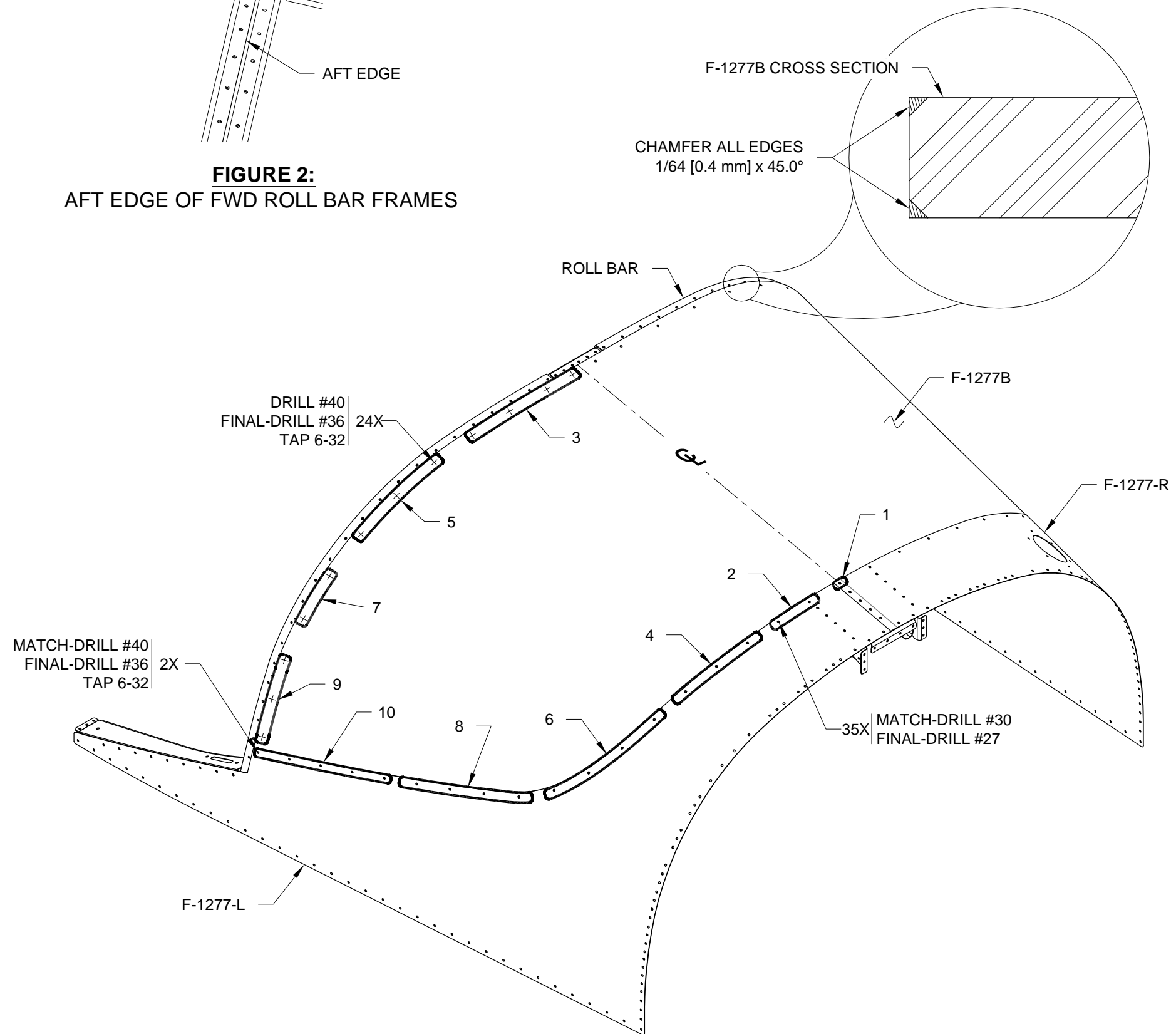

FIGURE 1: DRILL AFT WINDOW



NOTE: For better access to the fuselage during construction and to protect the F-1277B Aft Window, final installation of the window (as described on this page) can be delayed until the aircraft is nearly ready to fly.

Step 1: Install the F-1277B Aft Window on the fuselage using the hardware shown in Figure 2 and Figure 3. Use low torque to minimize stress on the window. Leave the screws/nuts common to the window and the F-1277-L & -R Fwd Turtle Deck Skins loose for now.

Step 2: Apply a line of quality tape (masking or electrical) to the outside of the F-1277-L & -R Fwd Turtle Deck Skins. Align the forward edge of the tape with the edge of the skins. Create a cutout in the tape for each screw head. See Detail A in Figure 1.

Step 3: Apply a line of quality tape to the inside of the F-1277-L & -R Fwd Turtle Deck Skins. Align the edge of the tape with the aft edge of the F-1277B Aft Window. See Detail B in Figure 1.

Step 4: Apply a line of quality tape to the outside of the F-1277B Aft Window. Offset the aft edge of the tape 1/16 in. [1.6 mm] from the edge of the skins. See Detail A in Figure 1.

Step 5: Cover the fuselage skin, aft window, and baggage area as required for easier cleanup after applying sealant to the aft window.

Step 6: Fabricate a popsicle stick tool as shown in Figure 4.

NOTE: The remaining steps on this page must be completed in a single work session.

Step 7: Put fuel tank sealant into a heavy-gauge plastic bag. Cut a corner off of the bag to create a Ø3/32 in. [Ø2.4 mm] hole. Apply the sealant by squeezing the mixture through the hole (the way a cake decorator would put frosting on a cake).

Step 8: Press inward on the F-1277B Aft Window to create a gap between the window and the F-1277-L & -R Fwd Turtle Deck Skins. Apply a 1/8 inch bead of fuel tank sealant between the window and the skins. The edge of the popsicle stick tool can be used as a spacer to keep the window and skins apart.

Step 9: Tighten the remaining window attach hardware. Use low torque to minimize stress on the F-1277B Aft Window.

Step 10: Use the radiused corner of the popsicle stick tool to create a fillet in the sealant that extrudes out between the F-1277B Aft Window and the F-1277-L & -R Turtle Deck Skins.

When satisfied with the appearance, and before the fuel tank sealant has cured, remove all of the tape to leave a crisp edge.

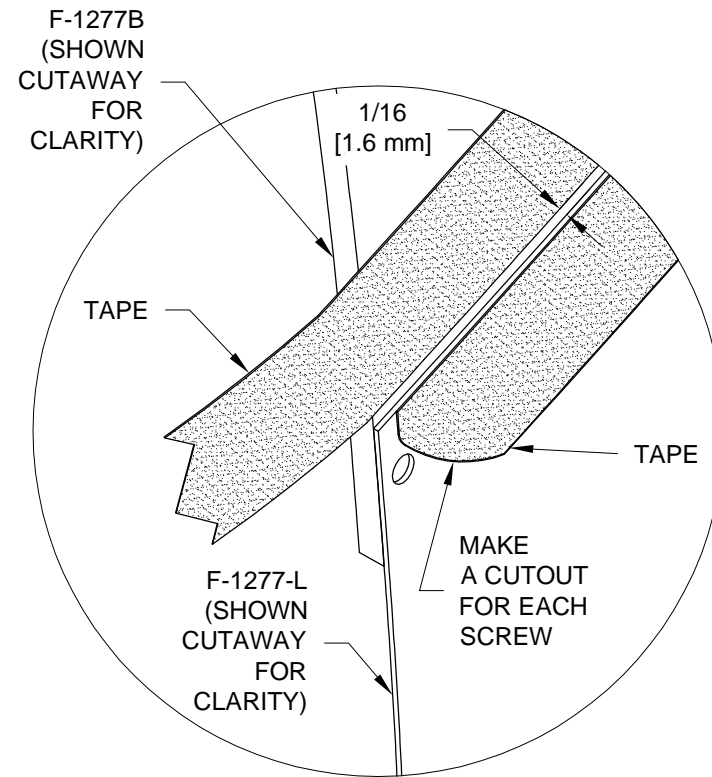

DETAIL A

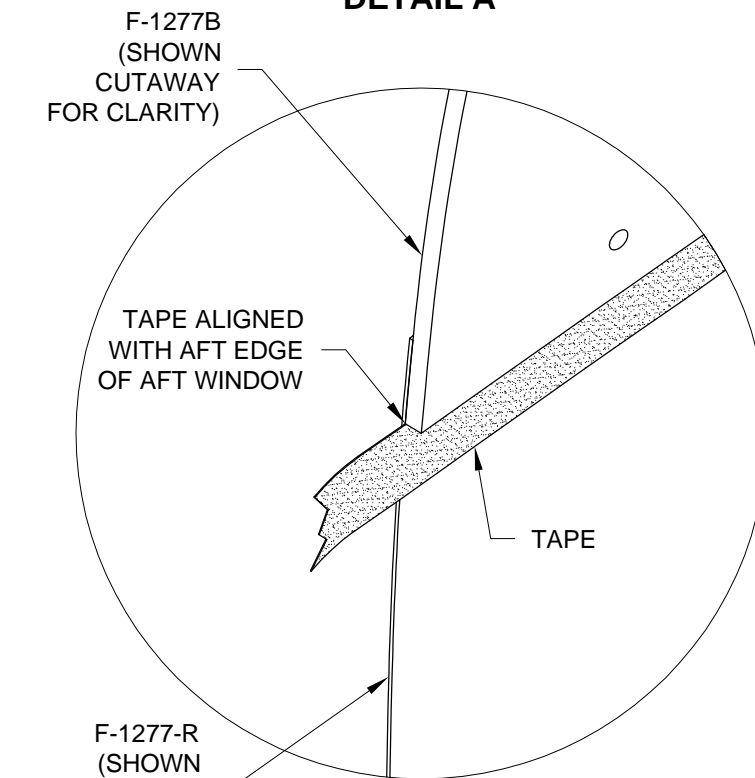

DETAIL B

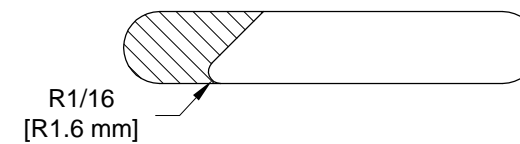

FIGURE 4: POPSICLE STICK TOOL

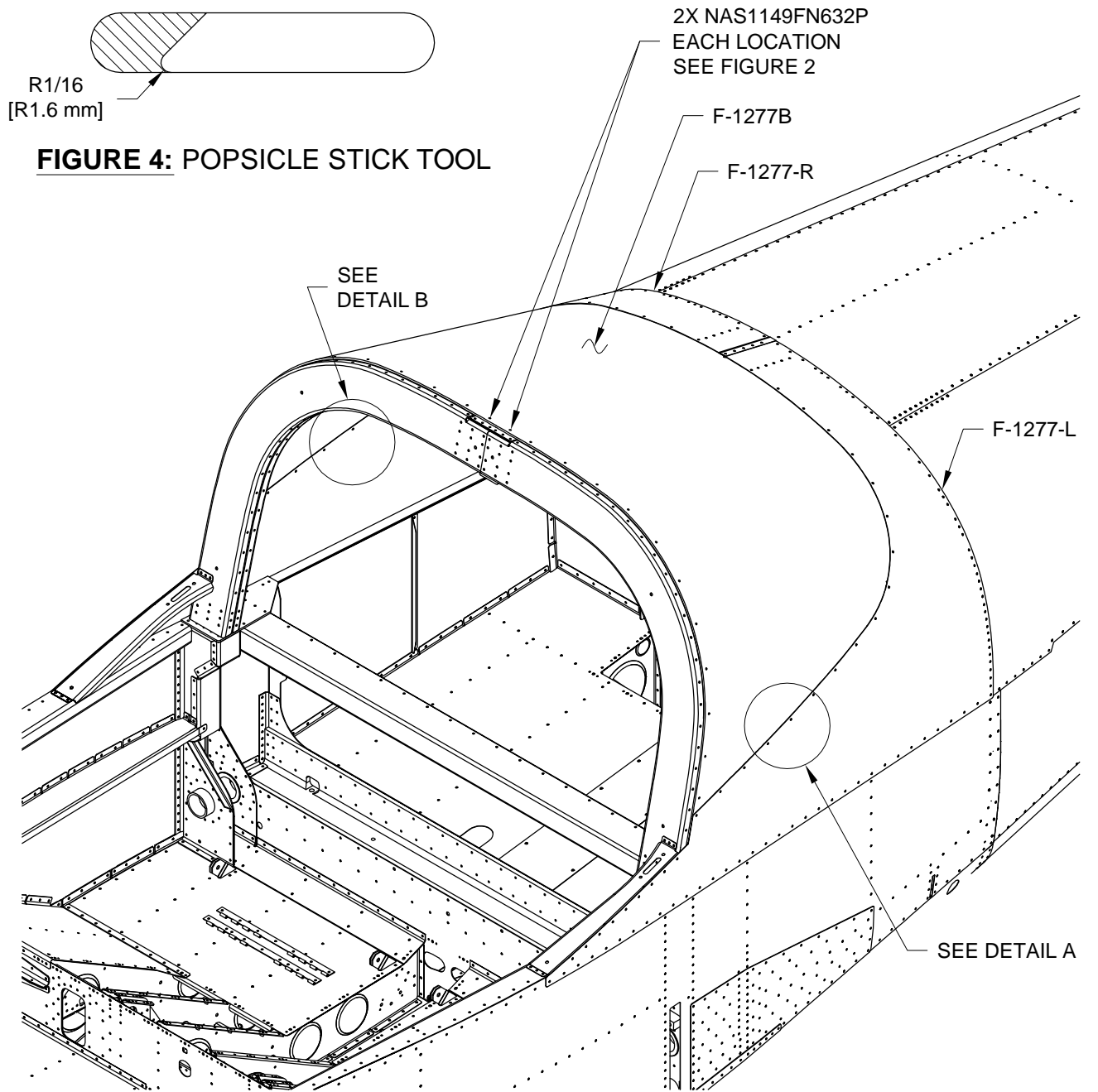

FIGURE 1: AFT WINDOW FINAL INSTALLATION

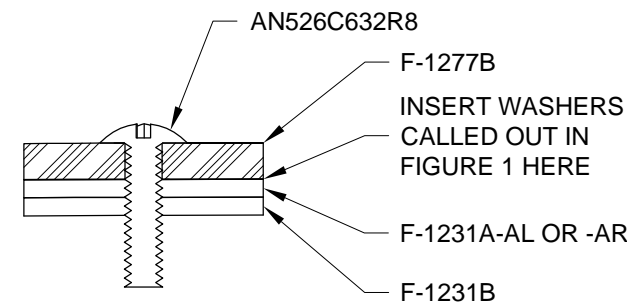

FIGURE 2: WINDOW TO ROLL BAR

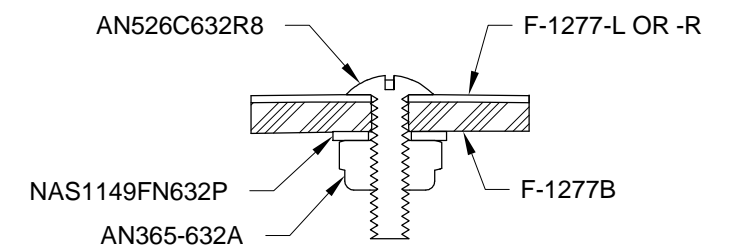

FIGURE 3: WINDOW TO SKIN