

SECTION 27U: ULS FUEL SYSTEM

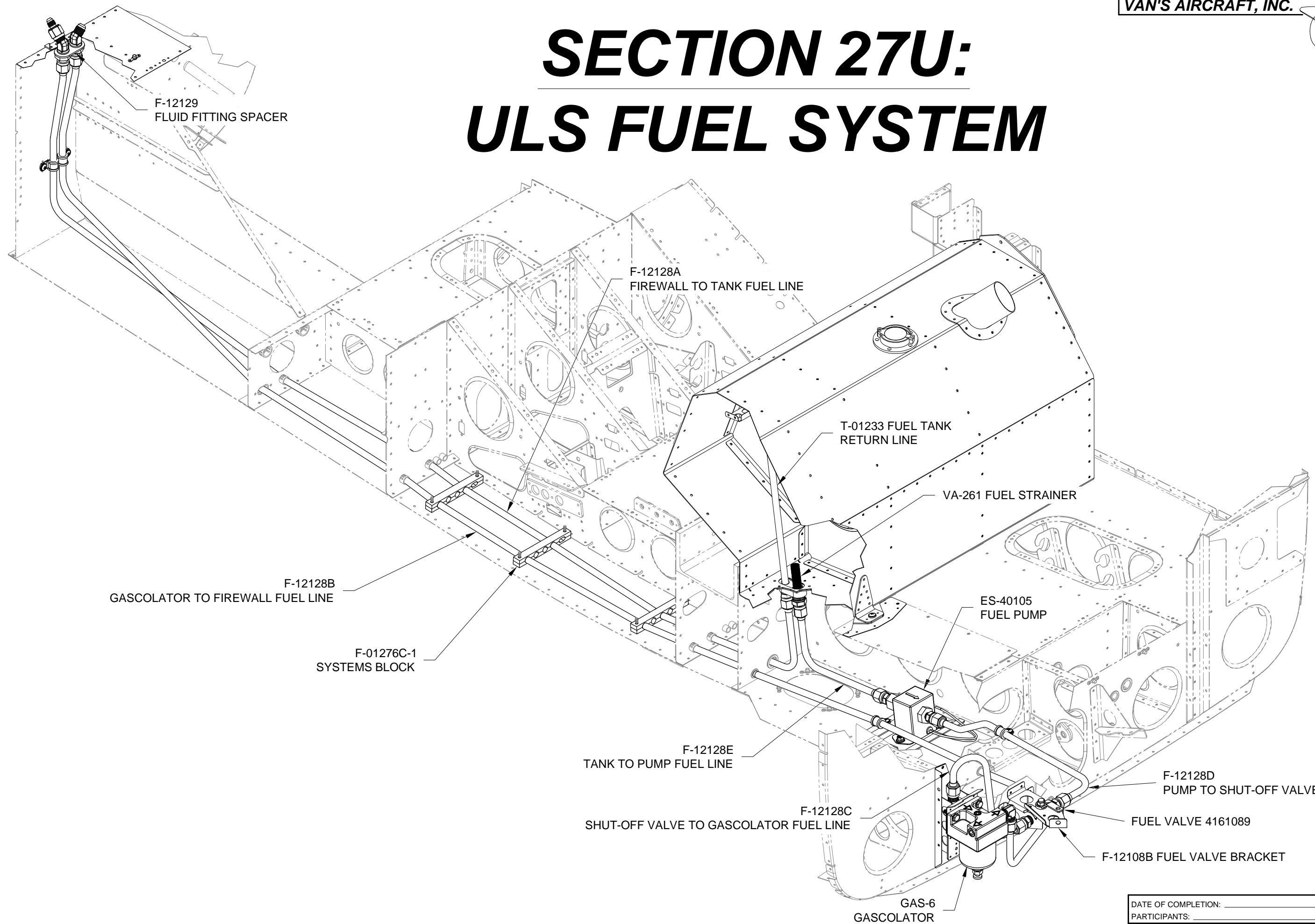

DATE OF COMPLETION: _____			
PARTICIPANTS: _____			
DATE: 09/18/17	REVISION: 0	RV-12iS	PAGE: 27U-01

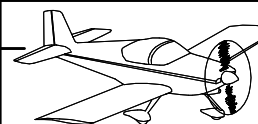

NOTE: It is good practice to cap or cover open fuel lines to keep out debris and prevent fuel system contamination.

NOTE: See Section 5.27 for detailed fluid fitting assembly instructions.

Step 1: Install the fluid fittings into the ES-40105 as shown in Figure 1.

Step 2: Slip the ring terminal from the black ground wire over the right screw and install the ES-40105 to the F-12113 as shown in Figure 1 (check the flow direction).

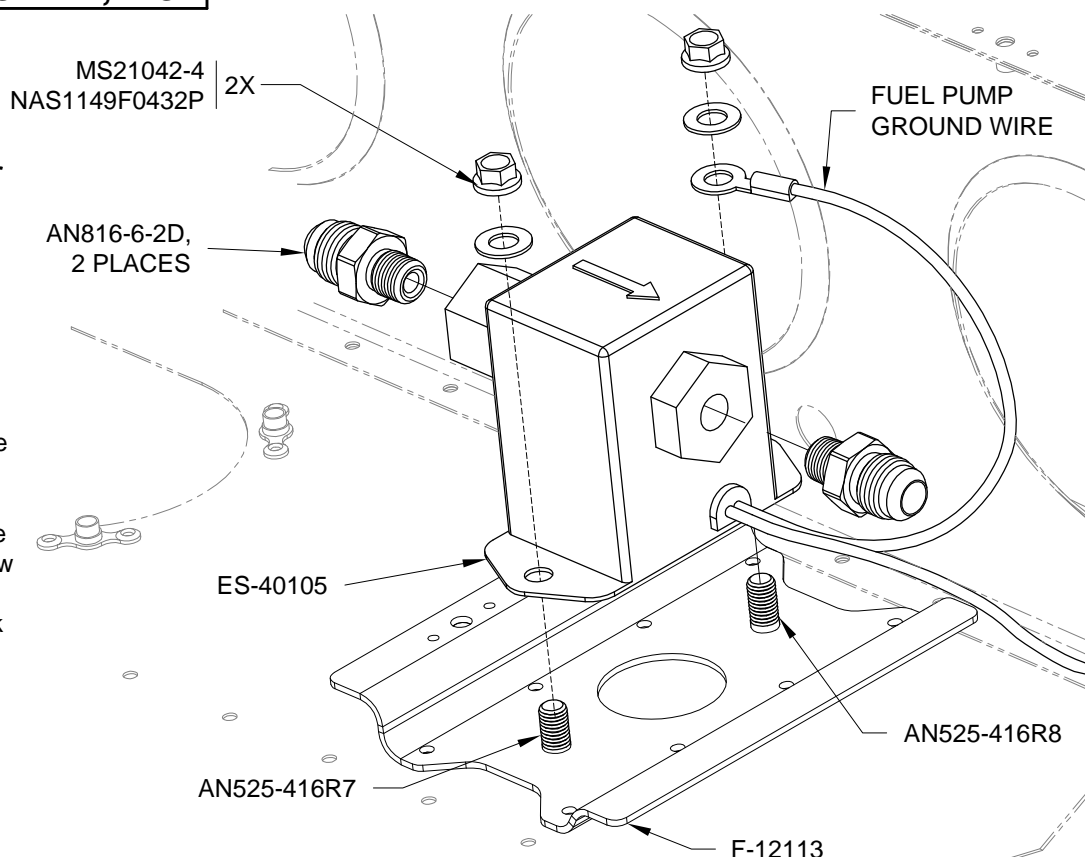

FIGURE 1: INSTALLING THE FUEL PUMP

Step 3: Drill 1/4" the Fuel Valve 4161089 handle per the dimensions given in Figure 2.

Step 4: Install the fluid fittings through the F-12108A and into the fuel valve as shown in Figure 3.

Step 5: Rivet the F-12108B per the call-outs in Figure 3.

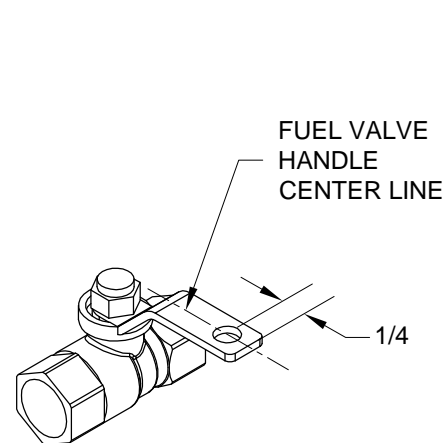

FIGURE 2: DRILLING THE FUEL VALVE 4161089 HANDLE

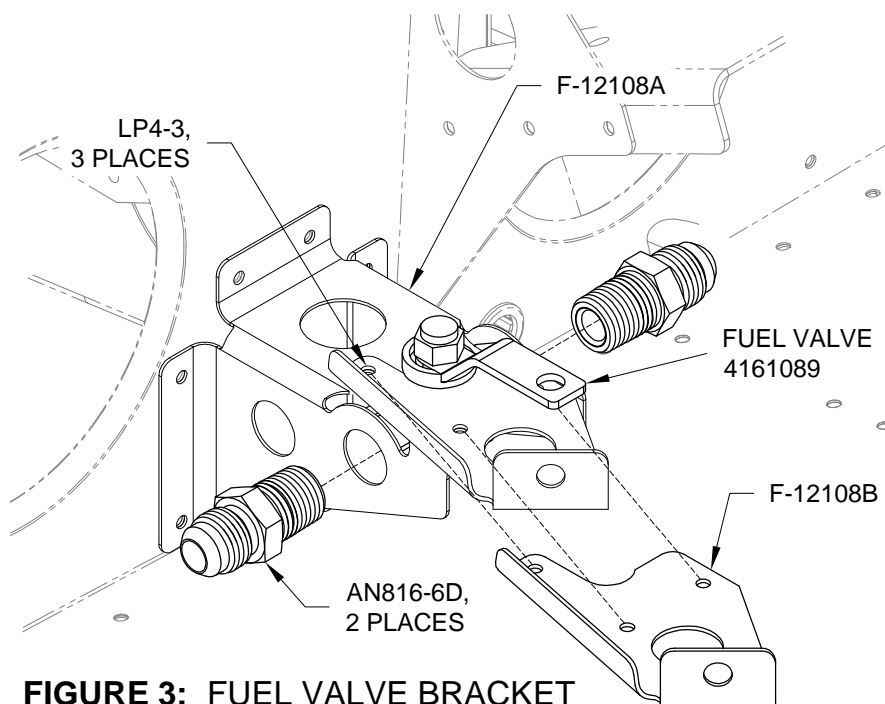

FIGURE 3: FUEL VALVE BRACKET ASSEMBLY

Step 6: Install both elbow fluid fittings, both plugs and the CAV-110 to the GAS-6 per the call-outs in Figure 4. Clock the fittings in the orientation shown.

Step 7: Safety wire the four screws holding the gascolator bowl to the top of the gascolator.

Step 8: Attach the gascolator to the F-12109A using the hardware called out in Figure 4.

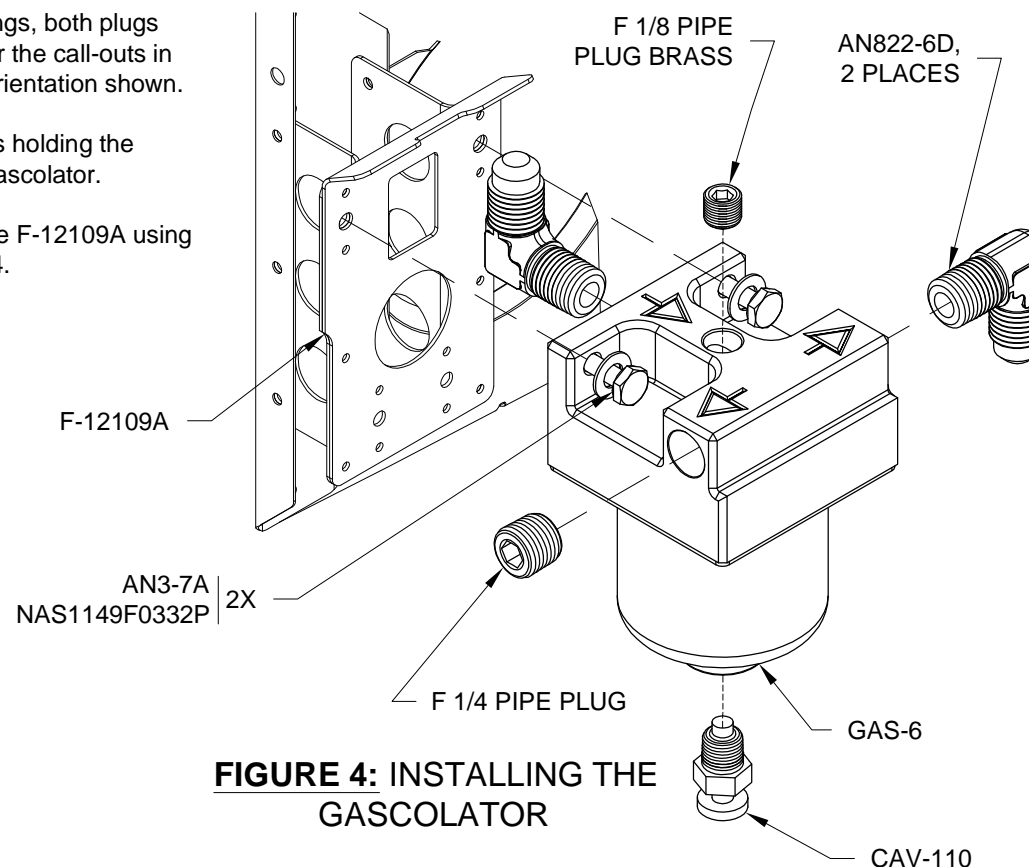

FIGURE 4: INSTALLING THE GASCOLATOR

Step 9: Install the fluid fittings, F-12129, and hardware onto the F-01201B-1 as shown in Figure 5. Apply a thin smear of fuel tank sealant between the fluid fittings and the firewall. Clock fittings in the orientation shown in Figure 6.

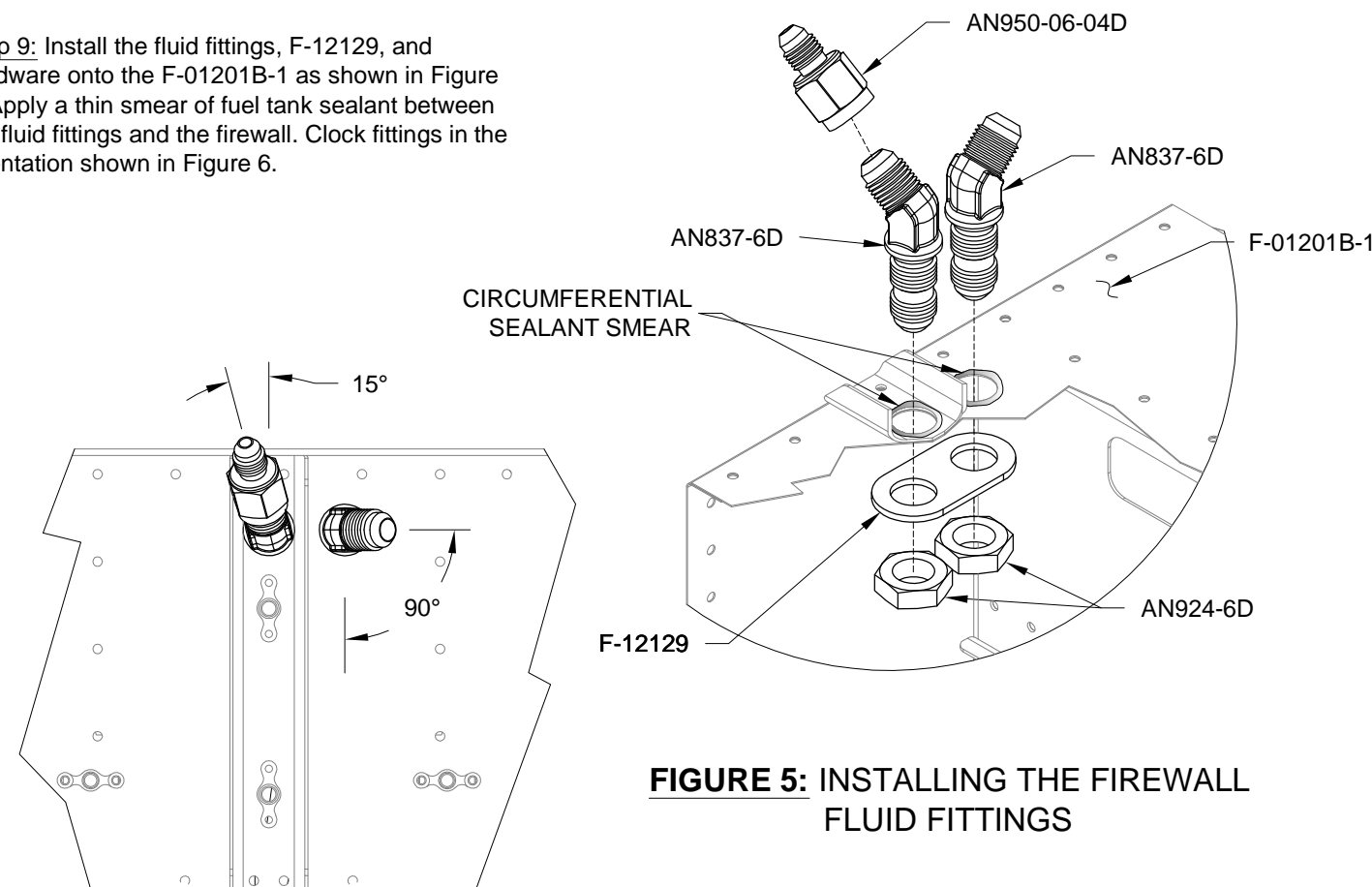
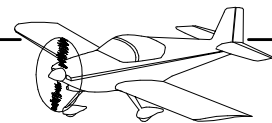

FIGURE 5: INSTALLING THE FIREWALL FLUID FITTINGS

FIGURE 6: FLUID FITTING CLOCKING



NOTE: The tubing dimensions given in this section include a 0.100 in. [2.5 mm] extension for each flare and assume a 1 in. radius to the centerline of the bend. See Figure 1.

NOTE: See Section 5.14 for important information on the process to fabricate fluid lines.

Step 1 (Builder Assembled Fuel Tank): The VA-261 and T-01233, shown in Figure 3, are installed in Section 26iS/U.

Step 1 (Prefabricated Fuel Tank): Install the VA-261 and T-01233, shown in Figure 3, as described in Section 26iS/U.

Step 2: Straighten 9 5/16 in. [236.5mm] of ATO-035X3/8 tubing. (Unrolling against a flat surface works well). Fabricate the F-12128E by starting at the pump end. Flare the end of the tube. Place the nut then the sleeve called out in Figure 2 over the end of the tubing. Slide the sleeve up against the flare. Flare the tank end of the tube.

Step 3: Make the bend going up to the tank by referencing Figure 2. Place the nut and sleeve over the end of the tube (check that the other nut and sleeve have not fallen off the tube). Flare the tank end of the tube.

Step 4: Temporarily attach the F-12128E to the VA-261 and ES-40105 as shown in Figure 3, but do not fully install at this time. A small amount of bending/adjustment by hand is acceptable. The F-12128E Fuel Line will be removed for access to fabricate and install other fuel lines and is permanently installed later.

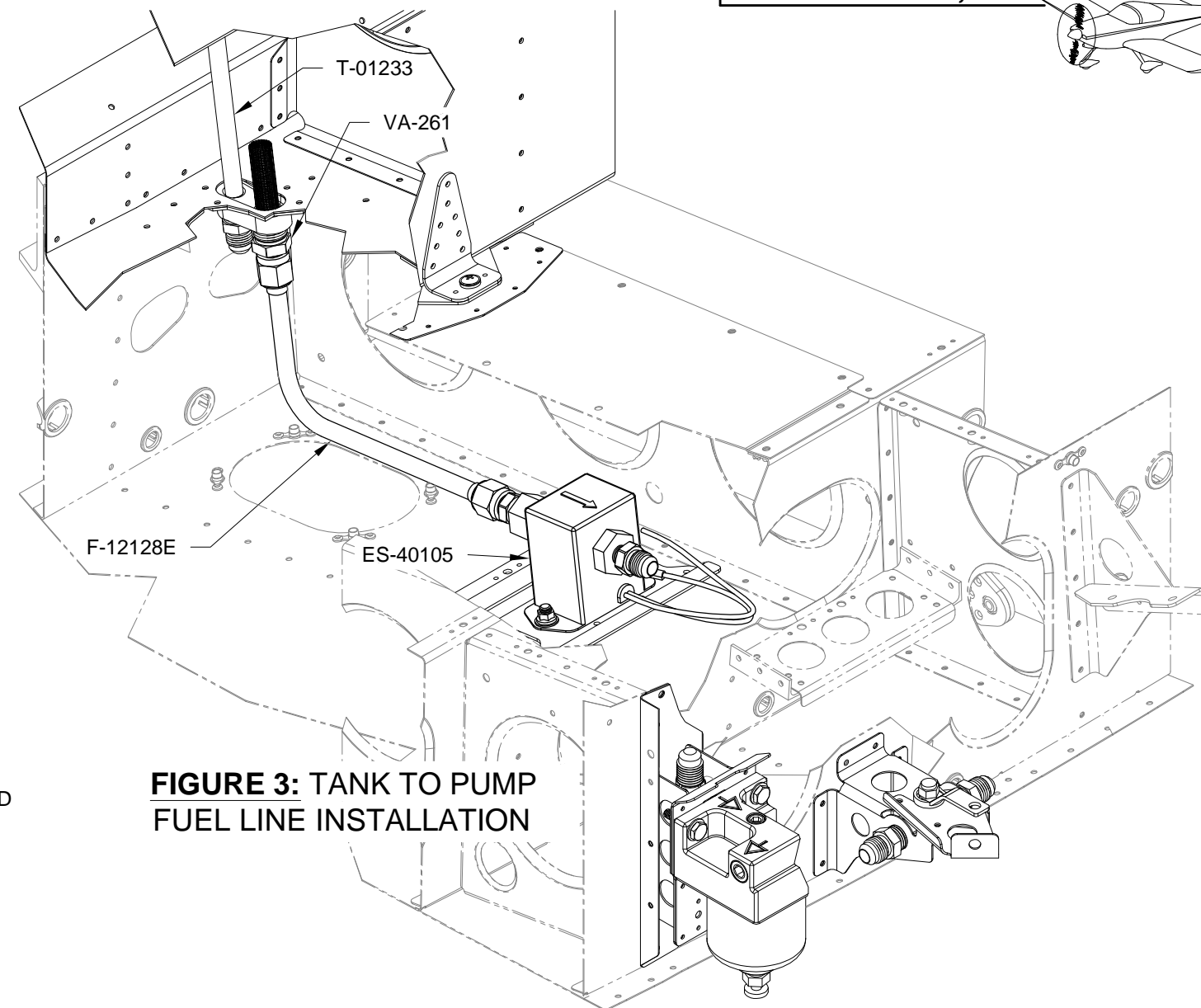

FIGURE 3: TANK TO PUMP FUEL LINE INSTALLATION

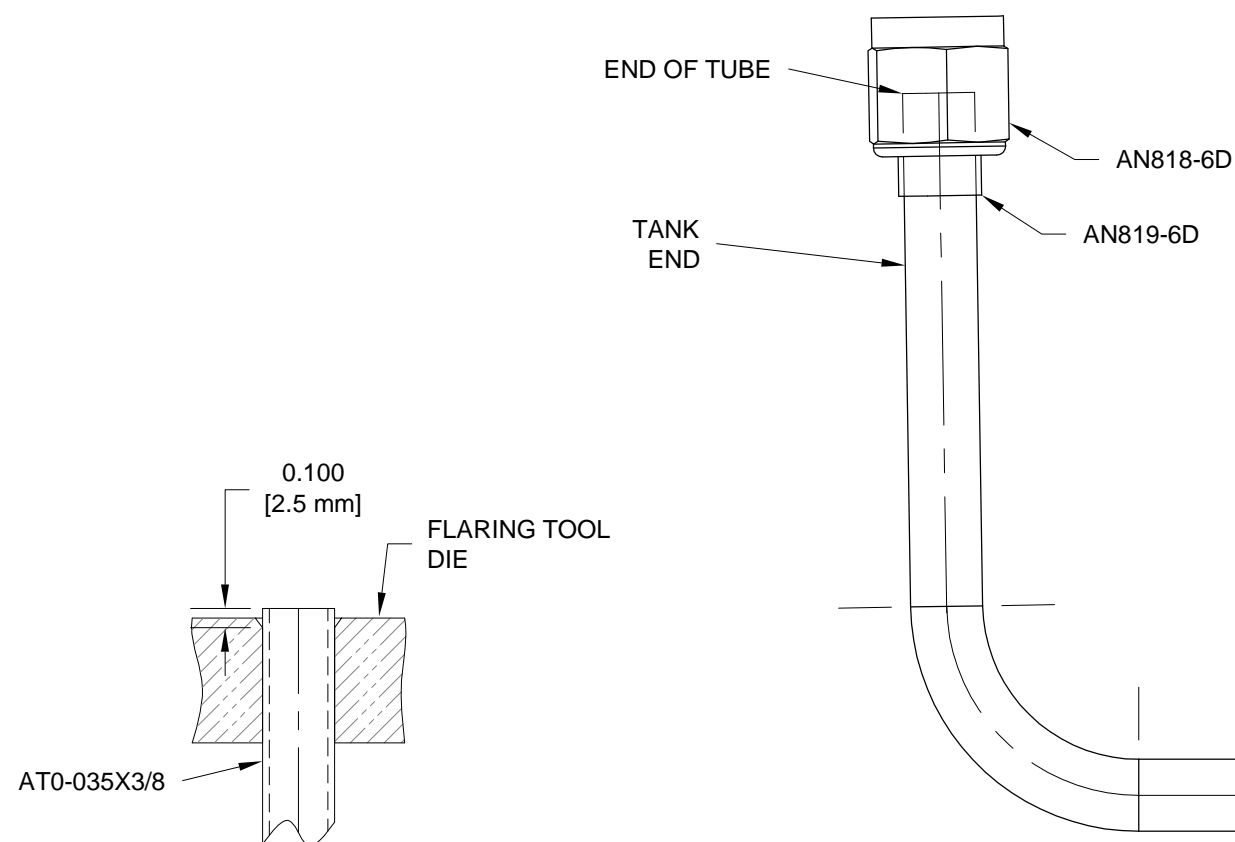

FIGURE 1: FLARING TOOL INSERTION

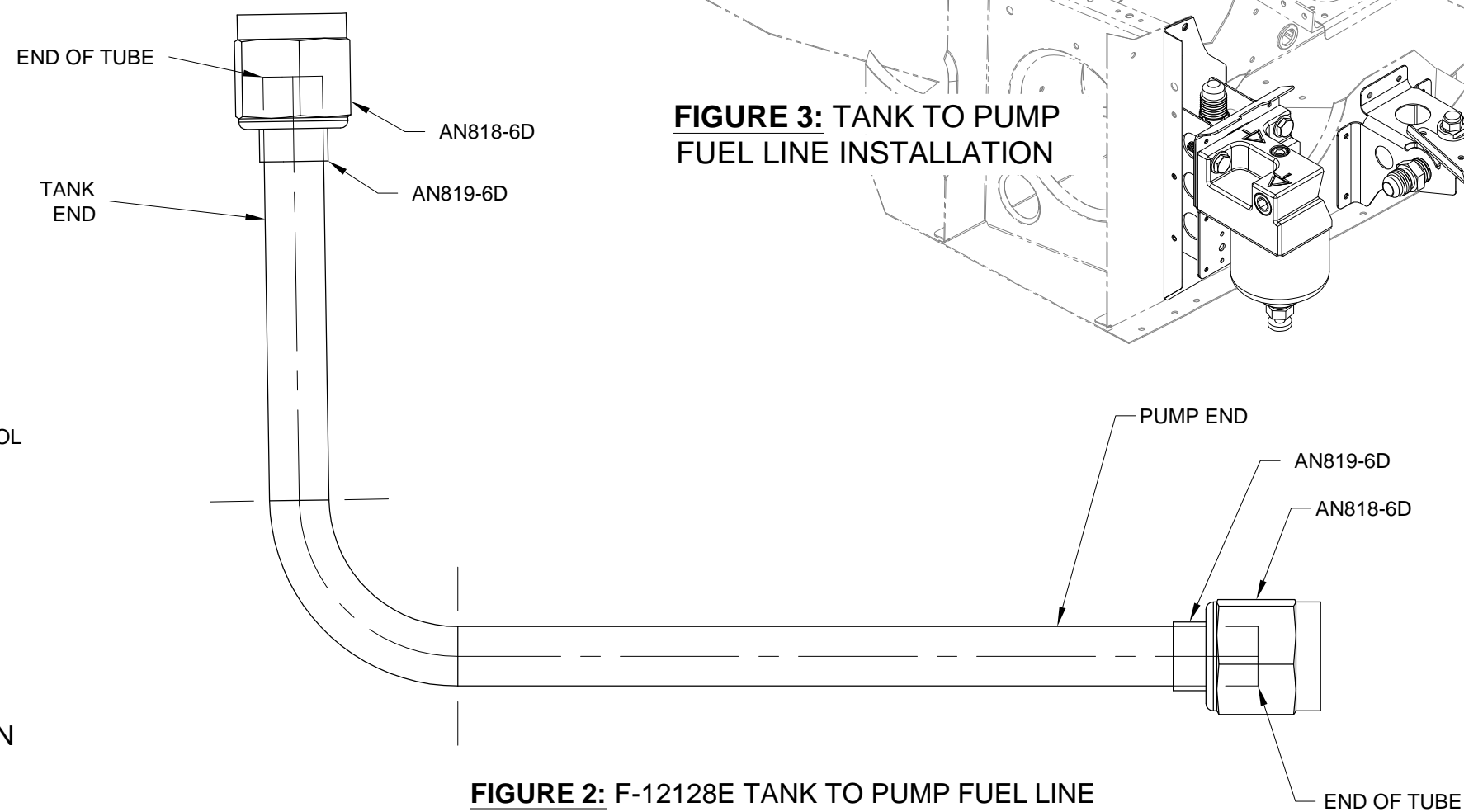
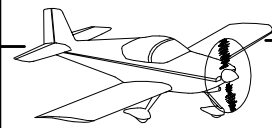

FIGURE 2: F-12128E TANK TO PUMP FUEL LINE (FULL SCALE)

(NOTE: CHECK PRINTED SCALE 1:1 PER SECTION 3 BEFORE USING THE TEMPLATE!)

10 9/16
[268.3 mm]

16
[406.4 mm]



Step 1: Straighten 15 in. [381.0 mm] of ATO-035X3/8 tubing. Make the F-12128D by starting at the pump end. Insert nut then the sleeve called out in Figure 2 over the end of the tubing. Flare the pump end of the tube. Slide the sleeve up against the flare.

Step 2: Make the 28° and 35° bends in the pump end by referencing Figure 2. Make the final 90° bend at the valve end by referencing Figure 1 and Figure 2, View A-A.

Step 3: Place nut and sleeve over the end of the tube (check that the other nut and sleeve have not fallen off the tube). Flare the valve end of the tube.

Step 4: Install the F-12128D as shown in Figure 1. A small amount of bending/adjustment by hand is acceptable.

Step 5: Place the clamp around the fuel line and install the screw and washers as shown in the detail view in Figure 1.

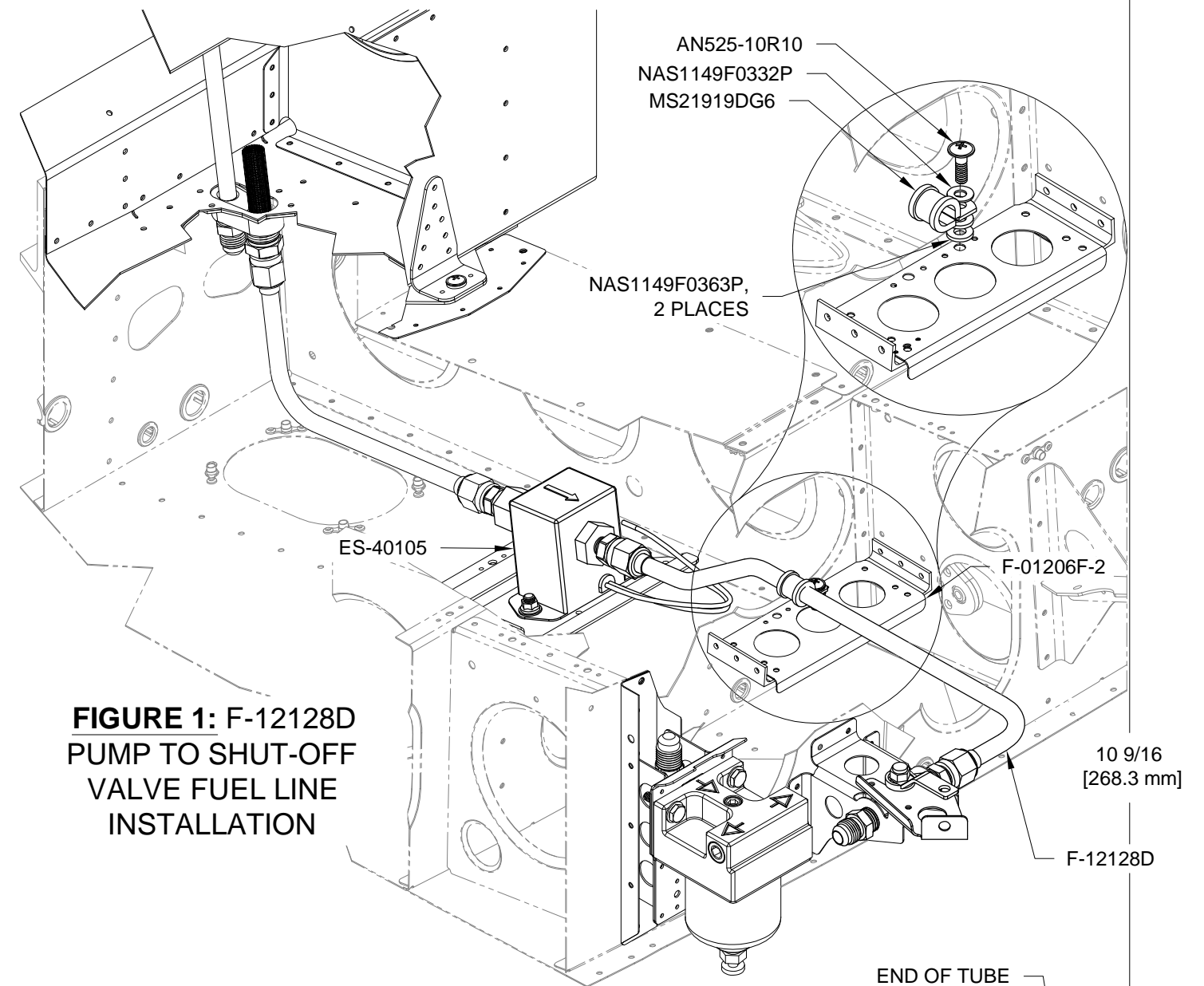

FIGURE 1: F-12128D PUMP TO SHUT-OFF VALVE FUEL LINE INSTALLATION

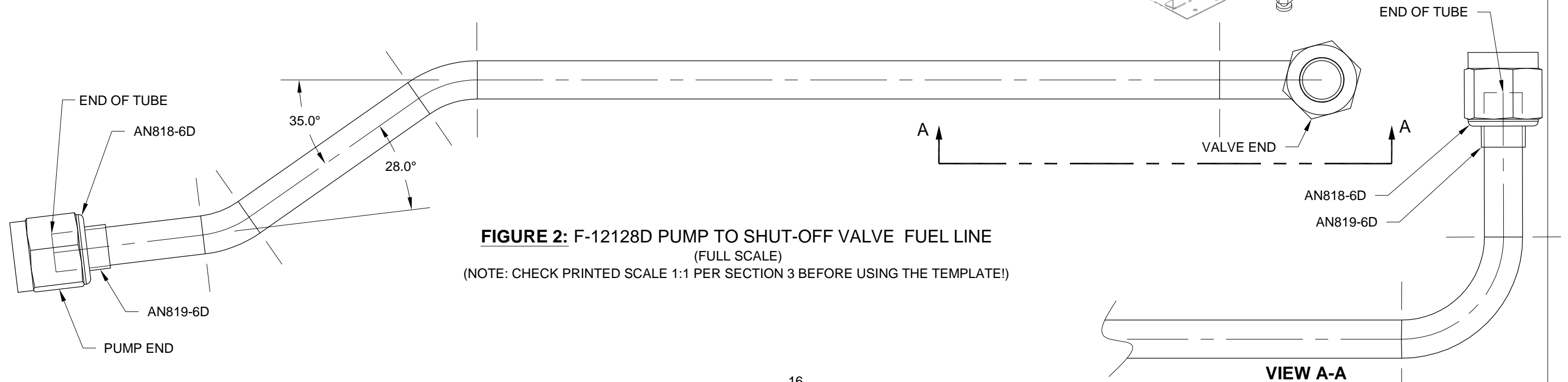

FIGURE 2: F-12128D PUMP TO SHUT-OFF VALVE FUEL LINE (FULL SCALE)
 (NOTE: CHECK PRINTED SCALE 1:1 PER SECTION 3 BEFORE USING THE TEMPLATE!)



Step 1: Straighten 11 3/32 in. [281.8 mm] of ATO-035X3/8 tubing. Make the F-12128C by starting at the gascolator end.

Measure 1 in. [25.4 mm] from the gascolator end and mark the start of bend line.

Measure 4 3/32 in. [104.0 mm] from the gascolator end of the tube and mark the end of bend line.

Make the 177° bend going to the gascolator by referencing Figure 2.

Step 2: Make the 87° bend going to the valve by referencing Figure 2 and View A-A.

Step 3: Place the nut and sleeve called out in Figure 2 over the gascolator end of the tubing. Flare the end of the tube. Slide the sleeve against the flare.

Place the nut and sleeve called out in Figure 2 over the valve end of the tube (check that the other nut and sleeve have not fallen off the tube). Flare the valve end of the tube.

Step 4: Install the fuel line to the fuel valve and gascolator as shown in Figure 1. A small amount of bending/adjustment by hand is acceptable.

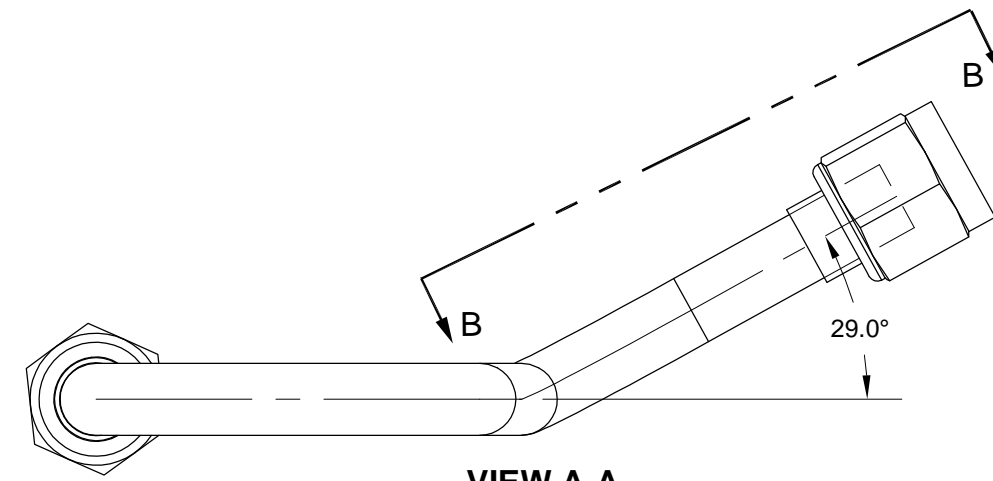

VIEW A-A

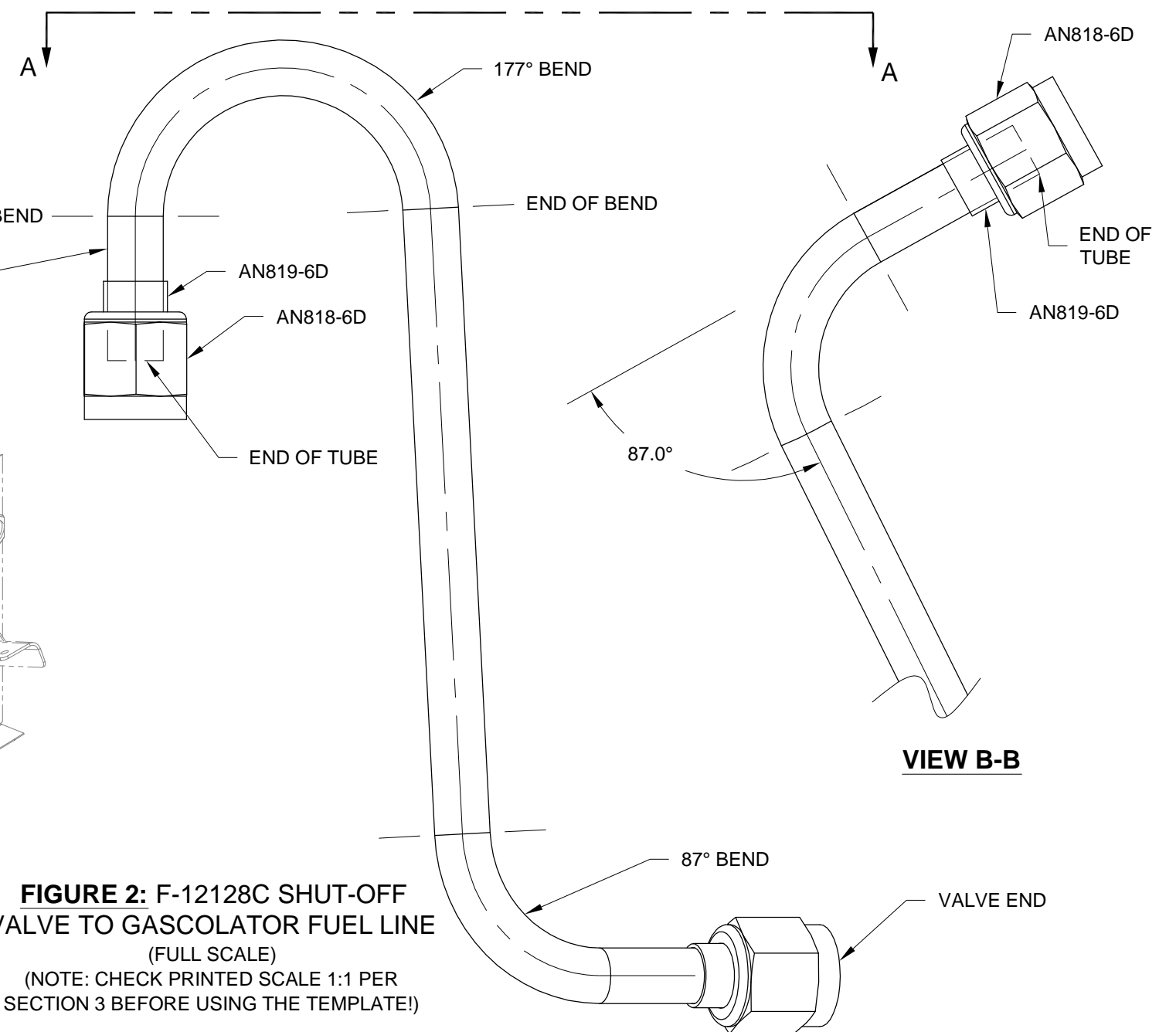

VIEW B-B

FIGURE 2: F-12128C SHUT-OFF VALVE TO GASCOLATOR FUEL LINE (FULL SCALE)
 (NOTE: CHECK PRINTED SCALE 1:1 PER SECTION 3 BEFORE USING THE TEMPLATE!)

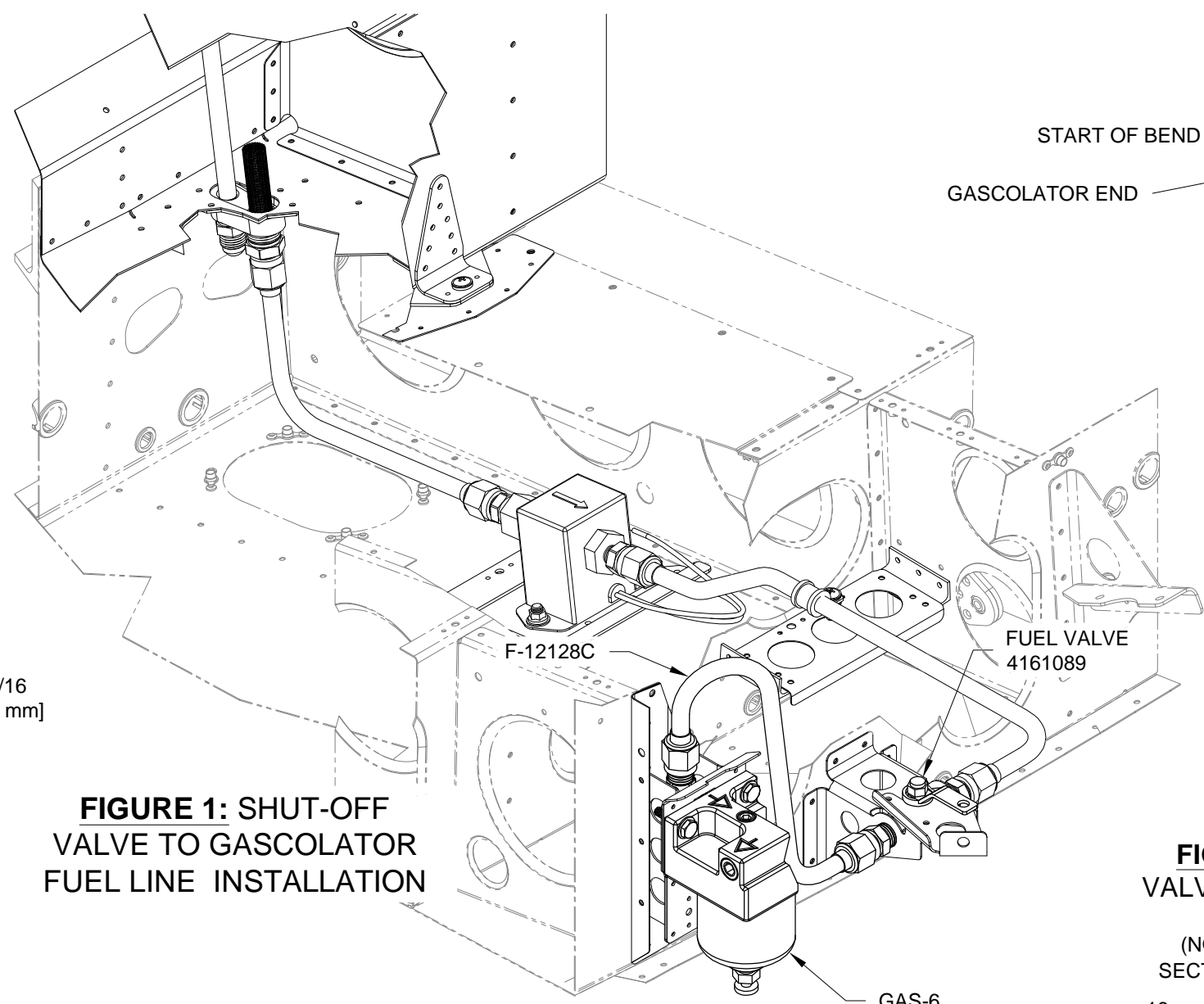

FIGURE 1: SHUT-OFF VALVE TO GASCOLATOR FUEL LINE INSTALLATION

16 [406.4 mm]



Step 1: Install the F-01276C-1's with oval recess on the right side, as shown in Figure 1.

NOTE: When installing fuel lines it is acceptable to bend a large radius curve by hand to ease installation, then restraighten afterwards.

NOTE: Check the installed fitting depth of the FLF-00017 Fitting against the nominal dimension as shown in the detail view in Figure 1. If the installed fitting depth is more than .063 in. [1.6 mm] different than the nominal dimension shown, adjust the tubing length in Step 2 and the bend location in Step 3 accordingly.

Step 2: Fabricate the F-12128A by straightening 74 7/16 in. [1890.7 mm] of ATO-035X3/8 tube. Start at the aft end of the tube. Place the nut and sleeve over the end of the tube and then flare the end.

Step 3: Make the 88° bend as shown on Page 27U-07, Figure 1.

Step 4: Measure 10 15/16 in. [277.8 mm] from the forward end of the fuel line and the mark start of bend line.

Measure 9 1/2 in. [241.3 mm] from the forward end of the fuel line and mark the end of bend line.

Step 5: Make the two shallow bends in the forward end of the fuel line as shown on Page 27U-07, Figure 2. Feed the fuel line through snap bushings to the firewall.

Step 6: Make the 82° bend towards the union bulkhead fittings as shown on Page 27U-07, Figure 2.

Place the nut and sleeve over the forward end of the tube and then flare the end.

Step 7: Slide the fuel line forward and attach the fuel line to the union bulkhead fitting.

Step 8: Align the fuel line with the firewall clamp as shown in Figure 1. A small amount of bending/adjustment by hand is acceptable. Attach the fuel line to the firewall with the hardware called out in Figure 1.

Step 9: Add slight bends at bulkhead locations as required to align the fuel line with the snap bushings and F-01276C-1 System Blocks. Lay the tube into the recesses of the F-01276C-1's as shown in Figure 1. Add a slight curve to follow the curvature of the F-01276-1 Bottom Skin.

Step 10: Attach the fuel line to FLF-00017 as shown in Figure 1.

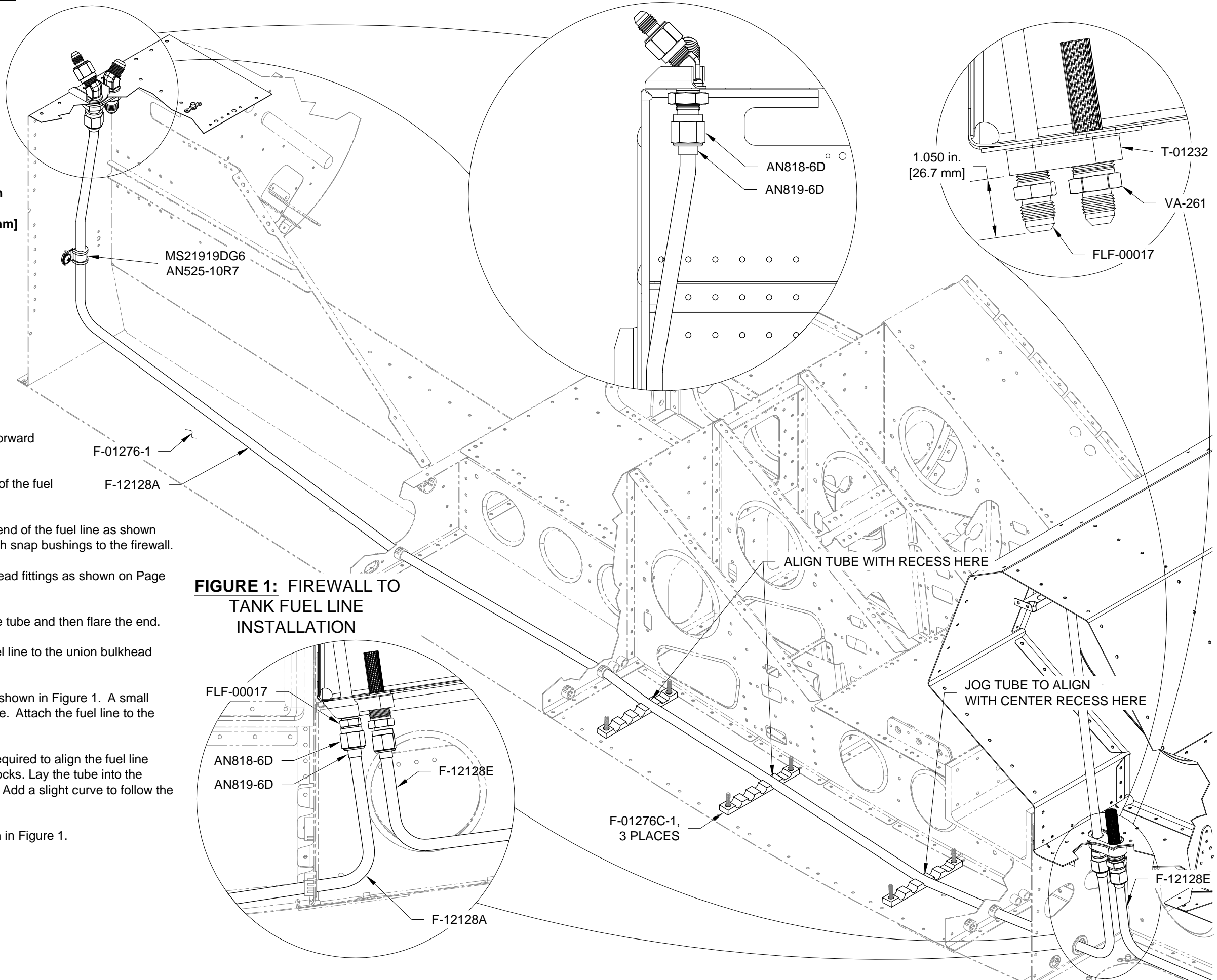
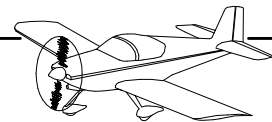

FIGURE 1: FIREWALL TO TANK FUEL LINE INSTALLATION



10 9/16
[268.3 mm]

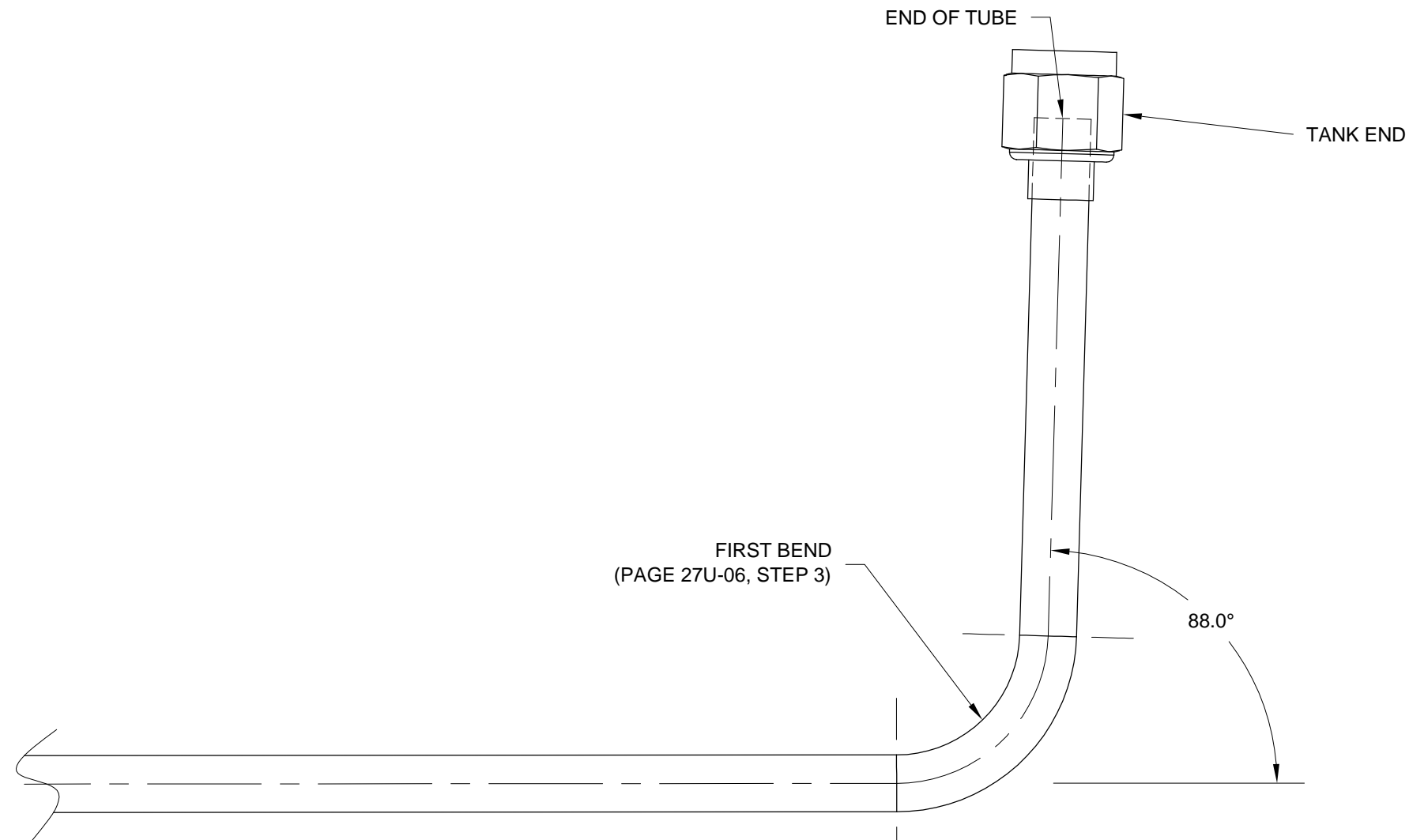

FIGURE 1: F-12128A FIREWALL TO TANK FUEL LINE

AFT BEND

(FULL SCALE)

(NOTE: CHECK PRINTED SCALE 1:1 PER SECTION 3 BEFORE USING THE TEMPLATE!)

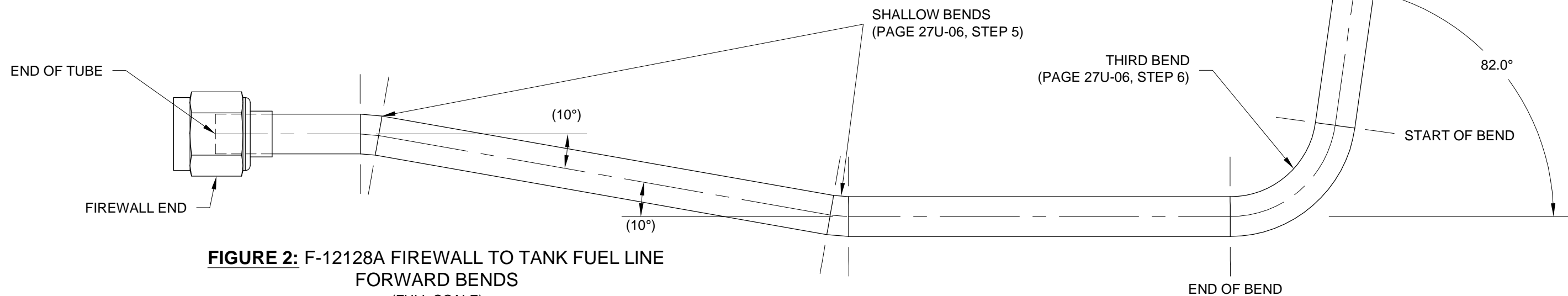

FIGURE 2: F-12128A FIREWALL TO TANK FUEL LINE

FORWARD BENDS

(FULL SCALE)

(NOTE: CHECK PRINTED SCALE 1:1 PER SECTION 3 BEFORE USING THE TEMPLATE!)

16
[406.4 mm]

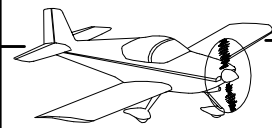

Step 1: Install the F-12128E to the fuel pump and fuel strainer as shown in Figure 1.

Step 2: Fabricate the F-12128B by straightening 102 7/8 in. [2613.0 mm] of ATO-035X3/8 tube.

Step 3: Start at the aft end of the fuel line. Make the 83° bend as shown on Page 27U-09, Figure 1.

Make the 75° bend as shown on Page 27U-09, Figure 1, View A-A.

Place the nut and sleeve over the aft end of the fuel line and then flare end.

Step 4: Measure back 9 7/8 in. [250.8 mm] from forward end of the tube and mark the start of bend line.

Measure back 8 7/16 in. [214.3 mm] from the forward end of the tube and mark the end of bend line.

Step 5: Make the two shallow bends as shown on Page 27U-09, Figure 2.

Feed the fuel line through the snap bushings to the firewall.

Step 6: Make the 79° bend towards the union bulkhead fitting in the firewall shelf as shown on Page 27U-09, Figure 2 using the bend lines marked in Step 4. Place the nut and sleeve over the forward end of the fuel line and then flare end.

Step 7: Slide the fuel line forward and attach the fuel line to the union bulkhead fitting as shown in the Detail View in Figure 1.

Step 8: Align the forward end of the fuel line with the firewall clamp. A small amount of bending/adjustment by hand is acceptable. Attach the fuel line to the firewall with the hardware called out in Figure 1.

Add slight bends at bulkhead locations as necessary to align the fuel line with the snap bushings and F-01276C-1 Systems Blocks. Lay the tube into the left most recess for a tube in the Systems Blocks adding a slight curve to follow the curvature of the F-01276-1 Bottom Skin.

Step 9: Attach the fuel line to the gascolator as shown in the detail view in Figure 1. A small amount of bending/adjustment by hand is acceptable.

Step 10: Attach the fuel line to the F-12113 with hardware called out in Figure 1.

Step 11: Check all fuel lines for clearance and chaffing on surrounding structure and components. Check that all fittings and connections are tightened.

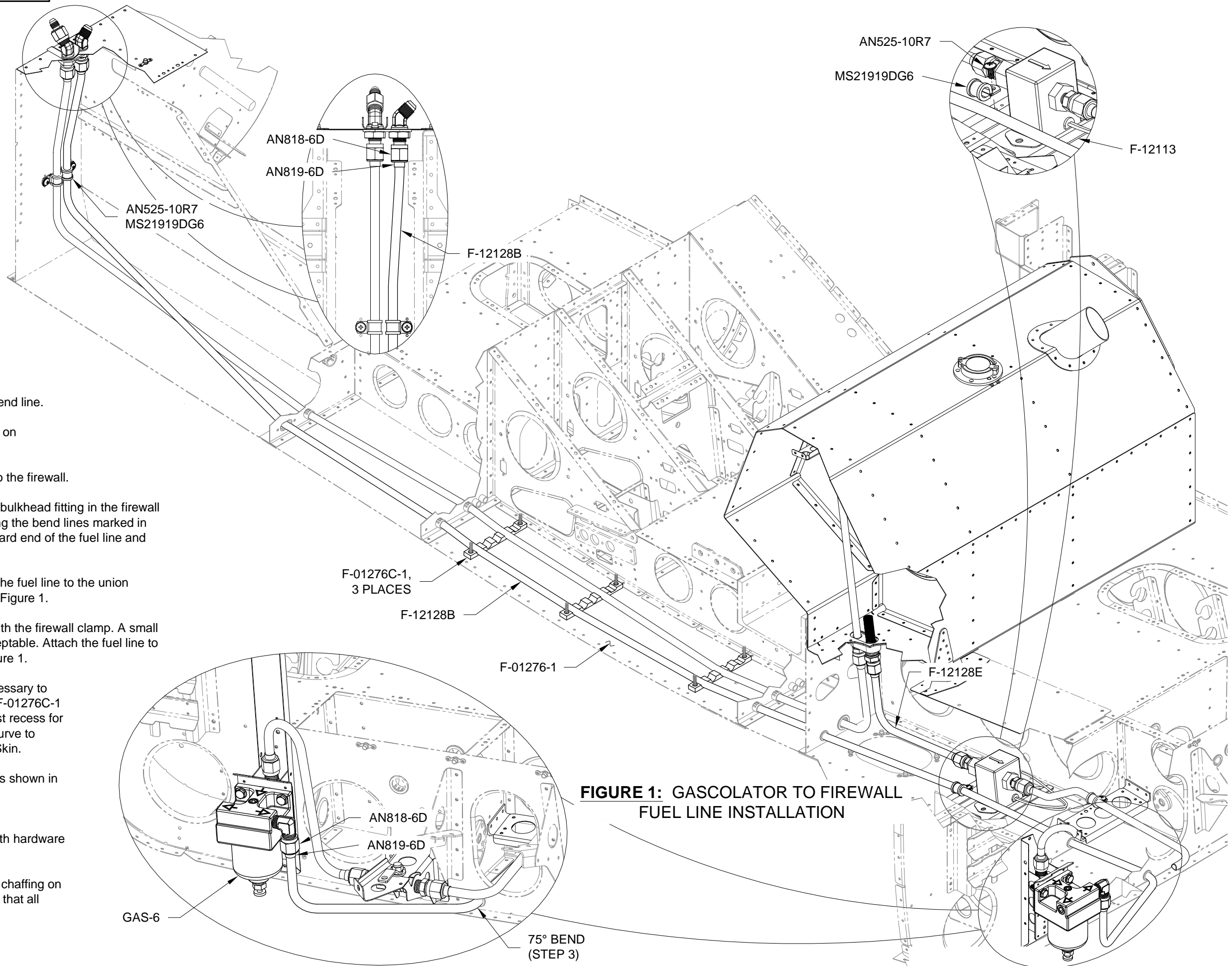
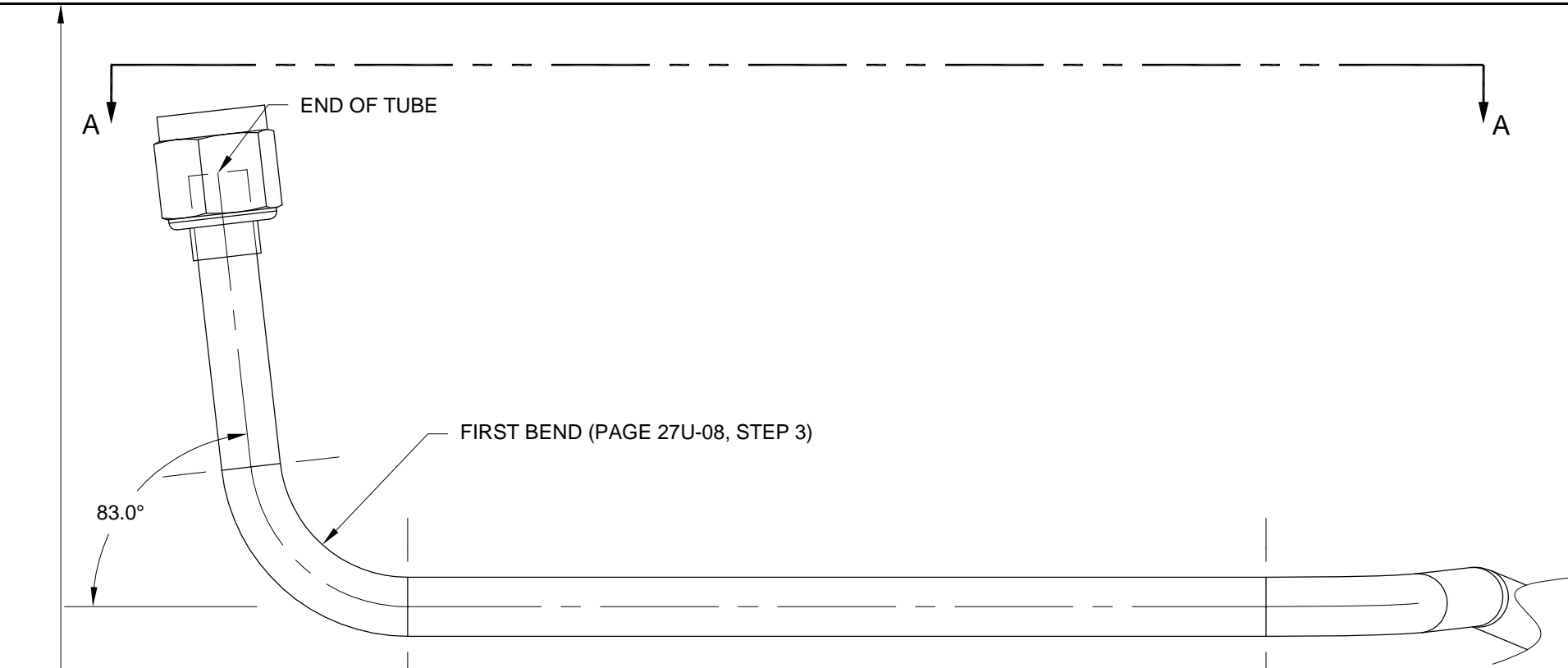
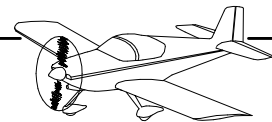

FIGURE 1: GASCOLATOR TO FIREWALL FUEL LINE INSTALLATION



**FIGURE 1: F-12128B GASCOLATOR TO FIREWALL FUEL LINE
AFT BENDS**

(FULL SCALE)
(NOTE: CHECK PRINTED SCALE 1:1 PER SECTION 3 BEFORE USING THE TEMPLATE!)

10 9/16
[268.3 mm]

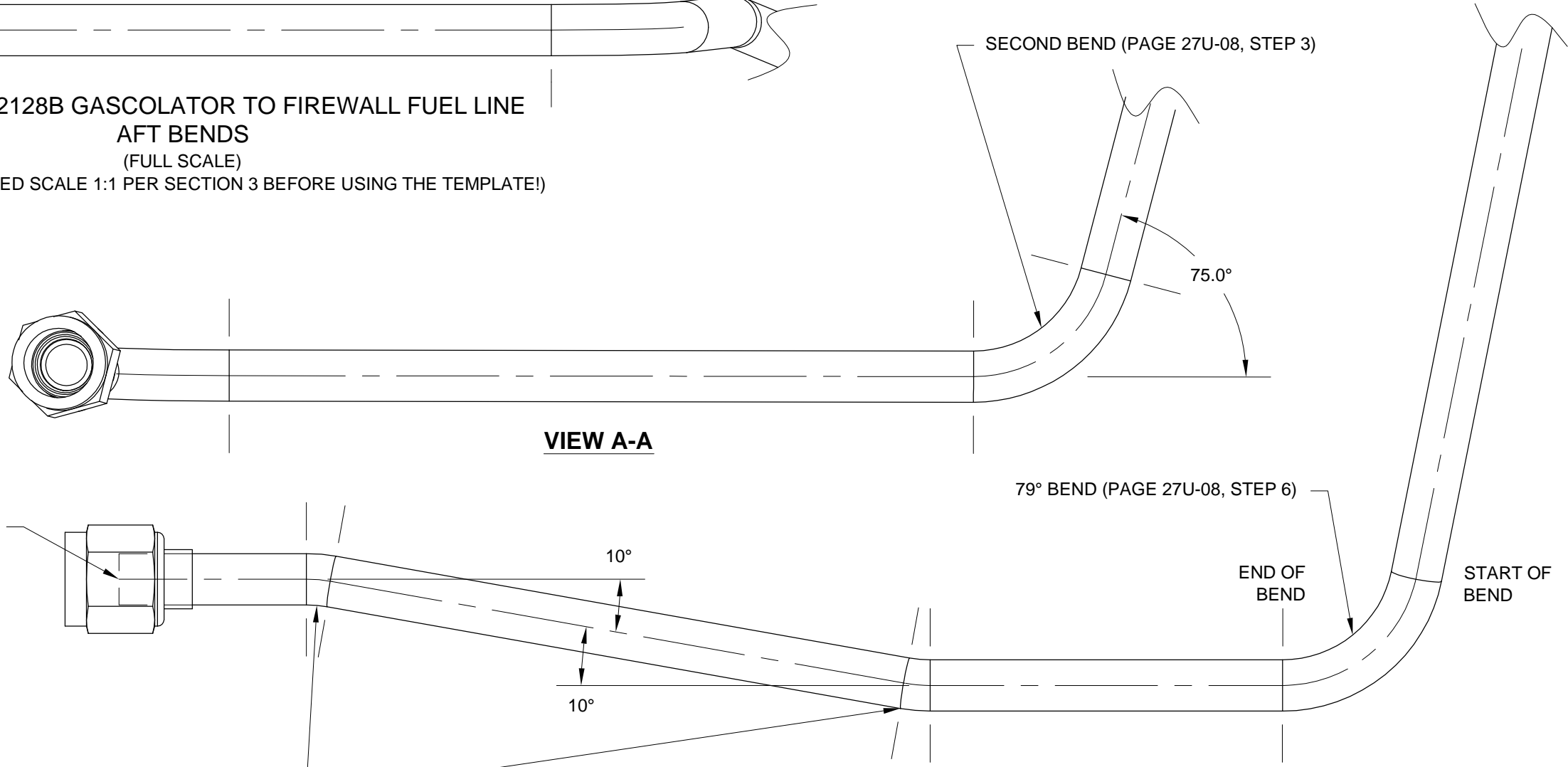

VIEW A-A

**FIGURE 2: F-12128B GASCOLATOR TO FIREWALL FUEL LINE
FORWARD BENDS**

(FULL SCALE)
(NOTE: CHECK PRINTED SCALE 1:1 PER SECTION 3 BEFORE USING THE TEMPLATE!)

16
[406.4 mm]

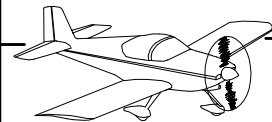

THIS PAGE INTENTIONALLY LEFT BLANK