

SECTION 36A: GEAR LEG & WHEEL FAIRINGS

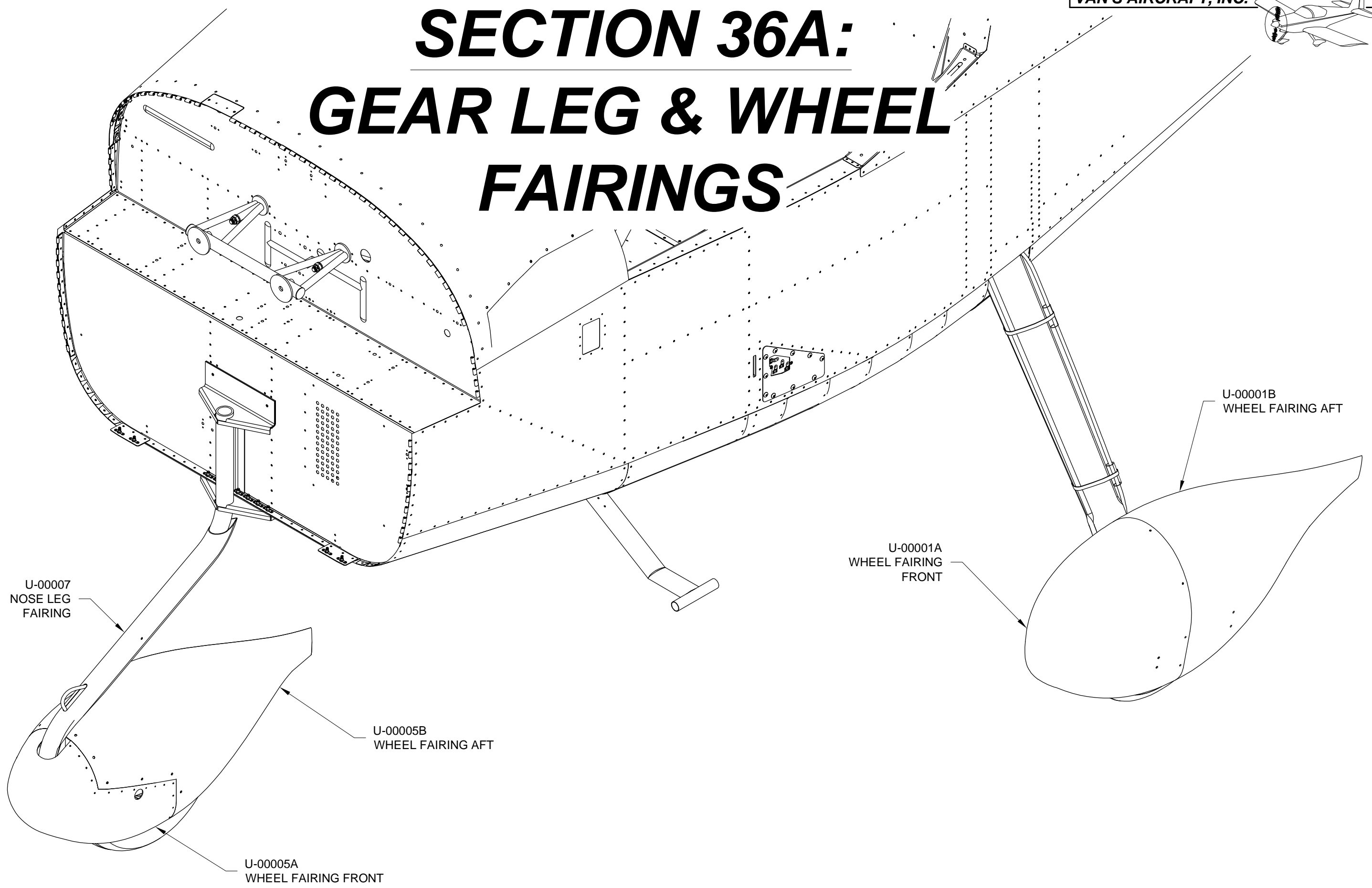

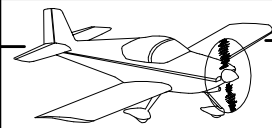

NOTE: This section provides instruction for the installation of the left wheel only. The right side is a mirror of the left.

NOTE: If transparent, the fairings in this section must remain transparent to accomplish the installation. Do not sand or prime either side of the fairings until directed to do so or until installation is complete.

If the fairings are opaque, refer to Section 5.18 MATCH-DRILLING OPAQUE FIBERGLASS PARTS.

The U-00001A Wheel Fairing Front and U-00001B Wheel Fairing Aft should mate as accurately as possible. Due to the variations in fiberglass molds it is necessary to first make the parts fit.

Step 1: The U-00001A Wheel Fairing Front has been laid up so that there are overlapping layers of cloth along its centerline. The area of overlap is thicker than the rest of the fairing. Sand down this thicker area so that at least 3/4 inch of the aft edge of the wheel fairing front is the same thickness all along its length.

Step 2: Trim the tire opening of the U-00001A Wheel Fairing Front to 1/16 inch from the scribe line with hand shears. Finish to the scribe line using a sanding block. See Figure 1.

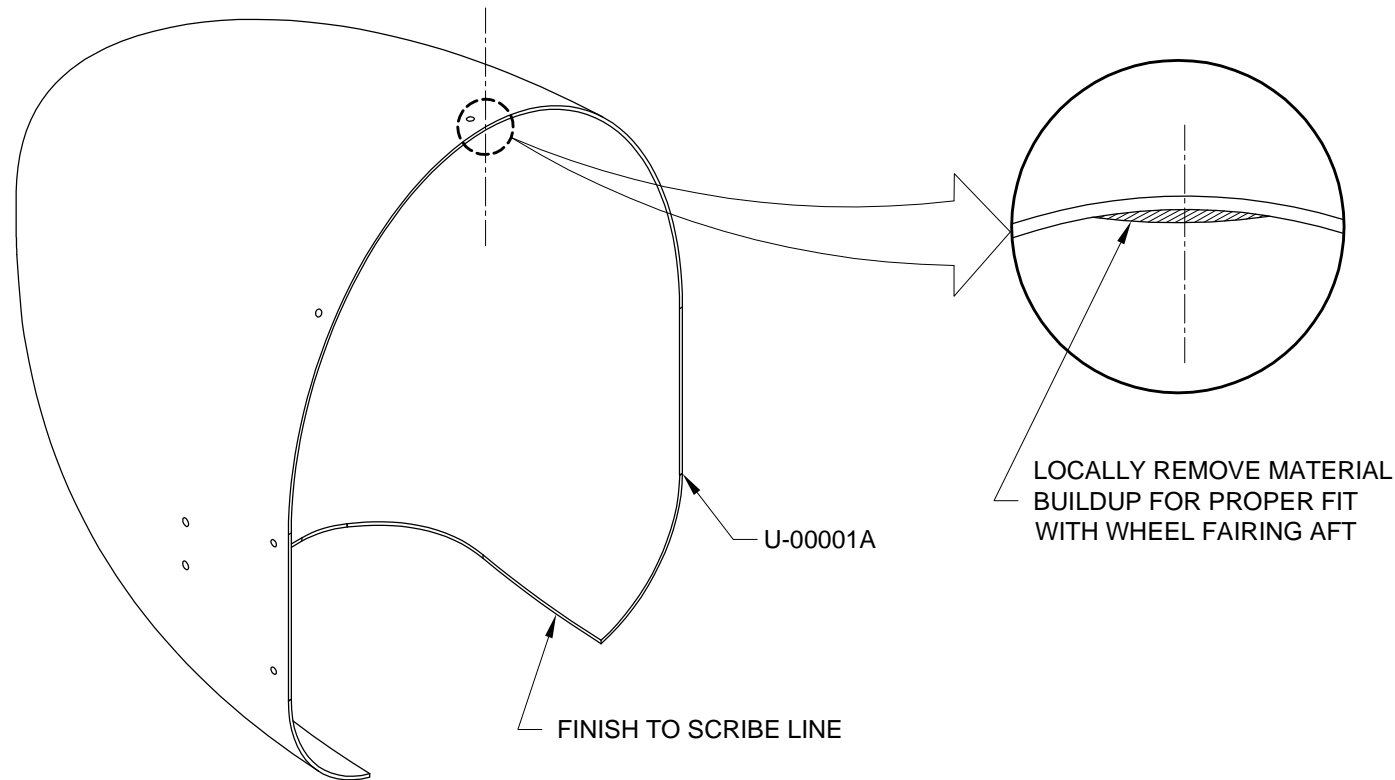

FIGURE 1: PREP FRONT FAIRING

Step 3: Square up the inside corner of molded step in the U-00001B Wheel Fairing Aft as required to allow for a good fit of the fairing halves as shown in Figure 2. A coarse file works well. Trim the wheel fairing aft flange to 3/4 inch from the molded step as shown in Figure 2.

Step 4: Trim the tire opening of the U-00001B Wheel Fairing Aft to 1/16 inch from the scribe line with hand shears. See Figure 2.

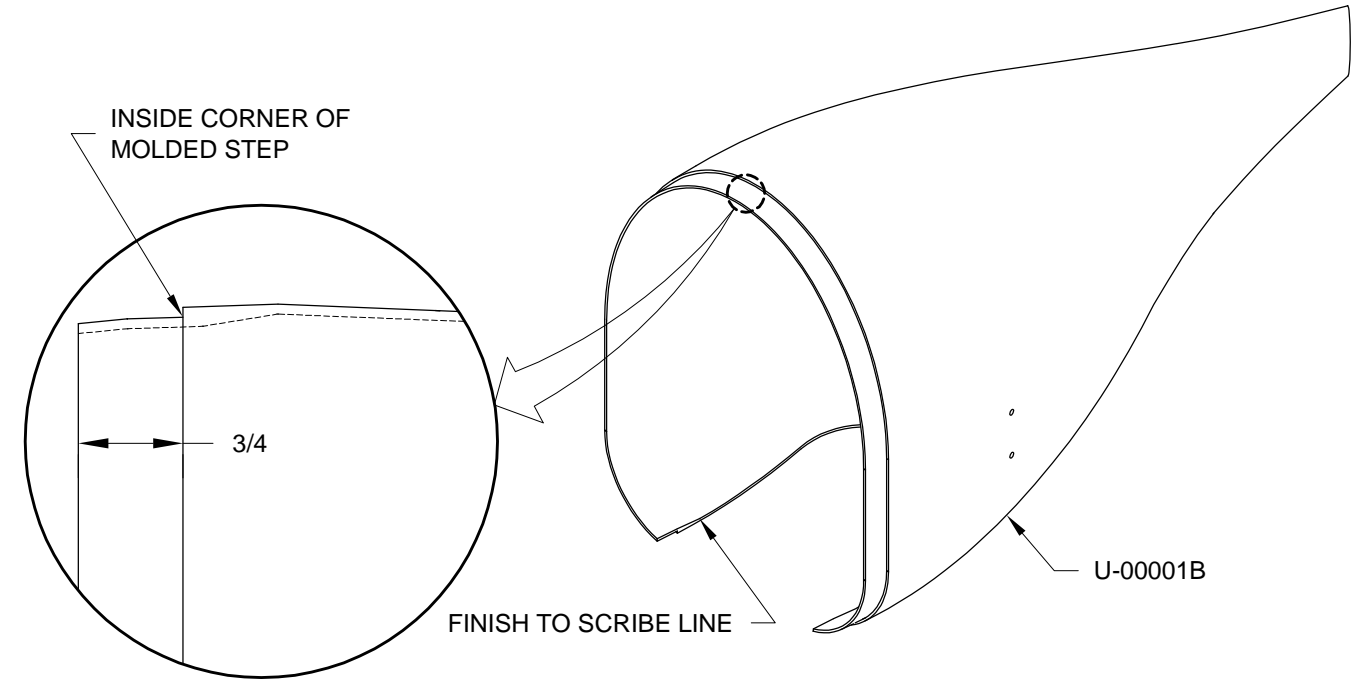

FIGURE 2: PREP REAR FAIRING

Step 5: Use coarse sandpaper glued to a straight stick as a disposable file to remove material up to the scribe line. Remove material that prevents the halves from matching smoothly. Take the time required to precision fit the wheel fairing halves.

Assemble the U-00001A Wheel Fairing Front and U-00001B Wheel Fairing Aft and align the wheel hole openings. Tape them in this position and place a tape reference mark across the seam. Slit the tape on the seam with a razor blade and use this mark to realign the fairings during assembly.

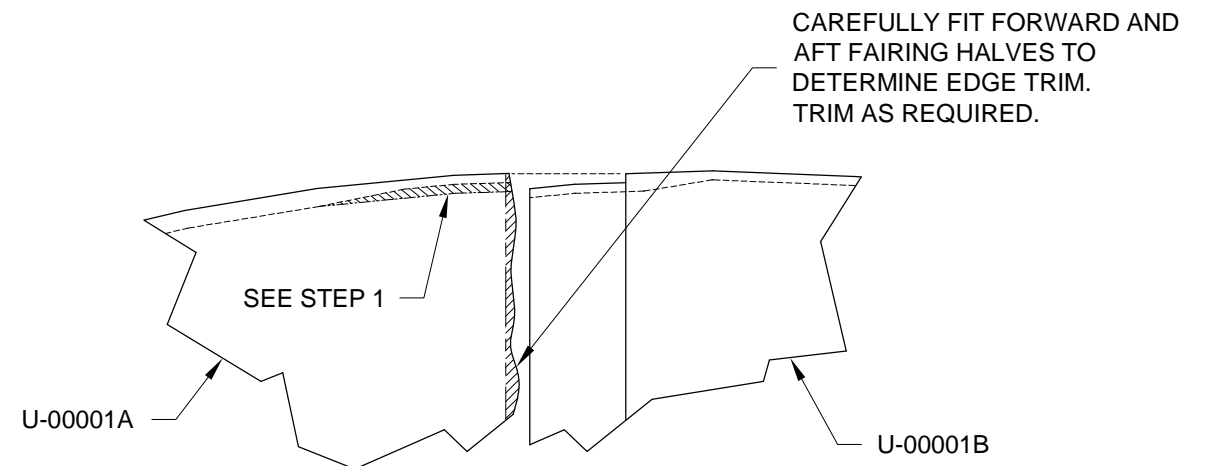
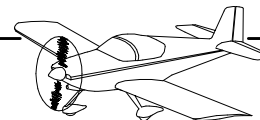

FIGURE 3: FIT AND TRIM FAIRING HALVES



Step 1: Check the length of each U-00002 Wheel Fairing Bracket for curve. If the part is curved, straighten as shown in Figure 1.

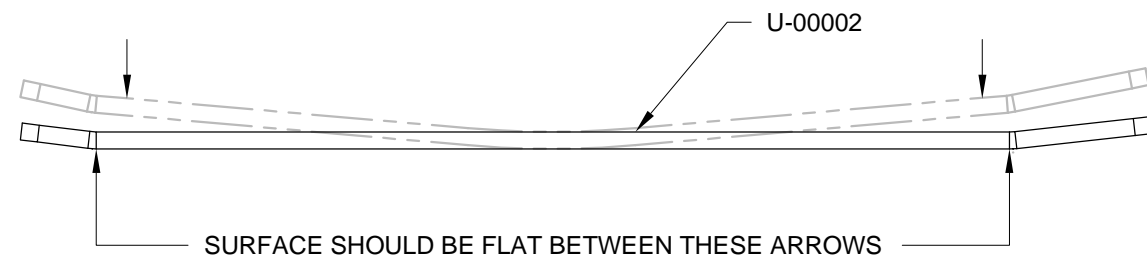

FIGURE 1: STRAIGHTENING THE WHEEL FAIRING BRACKETS

NOTE: Use a bright light shining through the opposite side of the U-00001A Wheel Fairing Front and U-00001B Wheel Fairing Aft to align the holes and dimples in the following step.

Step 2: With the U-00001A Wheel Fairing Front and U-00001B Wheel Fairing Aft joined, place a U-00002 Wheel Fairing Bracket flush on the interior surface of the wheel fairings. Align the holes in the wheel fairing bracket with the dimples in the wheel fairings. Check alignment on both sides of the wheel fairing halves. If required, sand the wheel fairing front's aft edge until the holes and dimples align properly. See Figure 2.

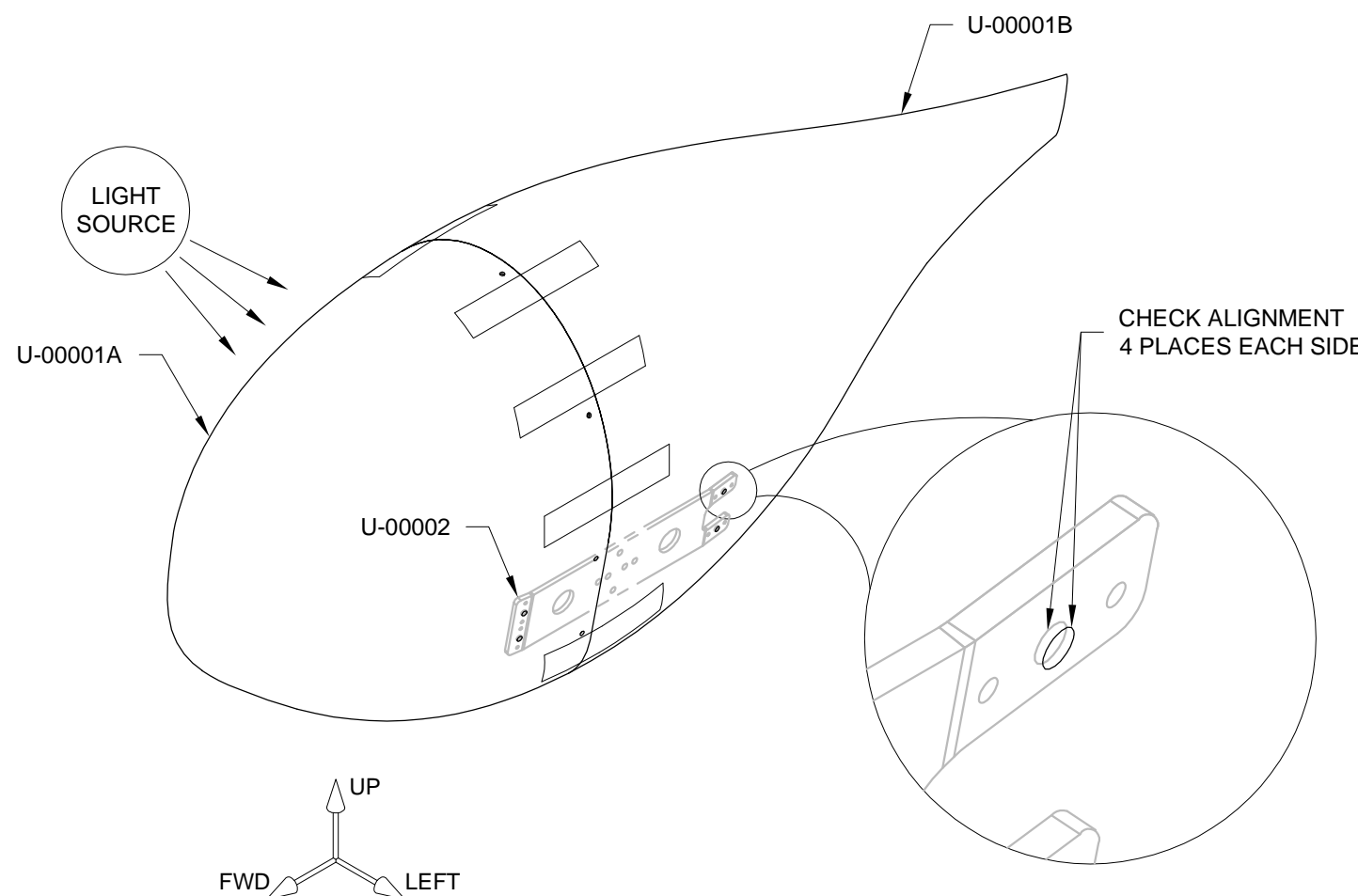

FIGURE 2: ALIGNING THE WHEEL FAIRING HALVES

Step 3: Join the U-00001A Wheel Fairing Front and U-00001B Wheel Fairing Aft as shown in Figure 3. Align the parts until they are fitting as well as possible then use several strips of tape to hold them together.

Using a #40 bit, match-drill the wheel fairing front to the wheel fairing aft at each of the nine "dimples" that are molded into the circumference of the wheel fairing front where it overlaps the wheel fairing aft. Cleco each drilled hole before drilling the next.

Begin match-drilling at the top-center and work downward, alternating side-to-side until all nine dimples have been drilled.

Hold the drill bit perpendicular to the surface of the wheel fairing halves while match-drilling.

Be aware of debris between parts as drilling progresses. Take apart and clean-out as necessary.

Step 4: Drill #30 the two dimples on each side of the U-00001A Wheel Fairing Front and U-00001B Wheel Fairing Aft as called-out in Figure 3.

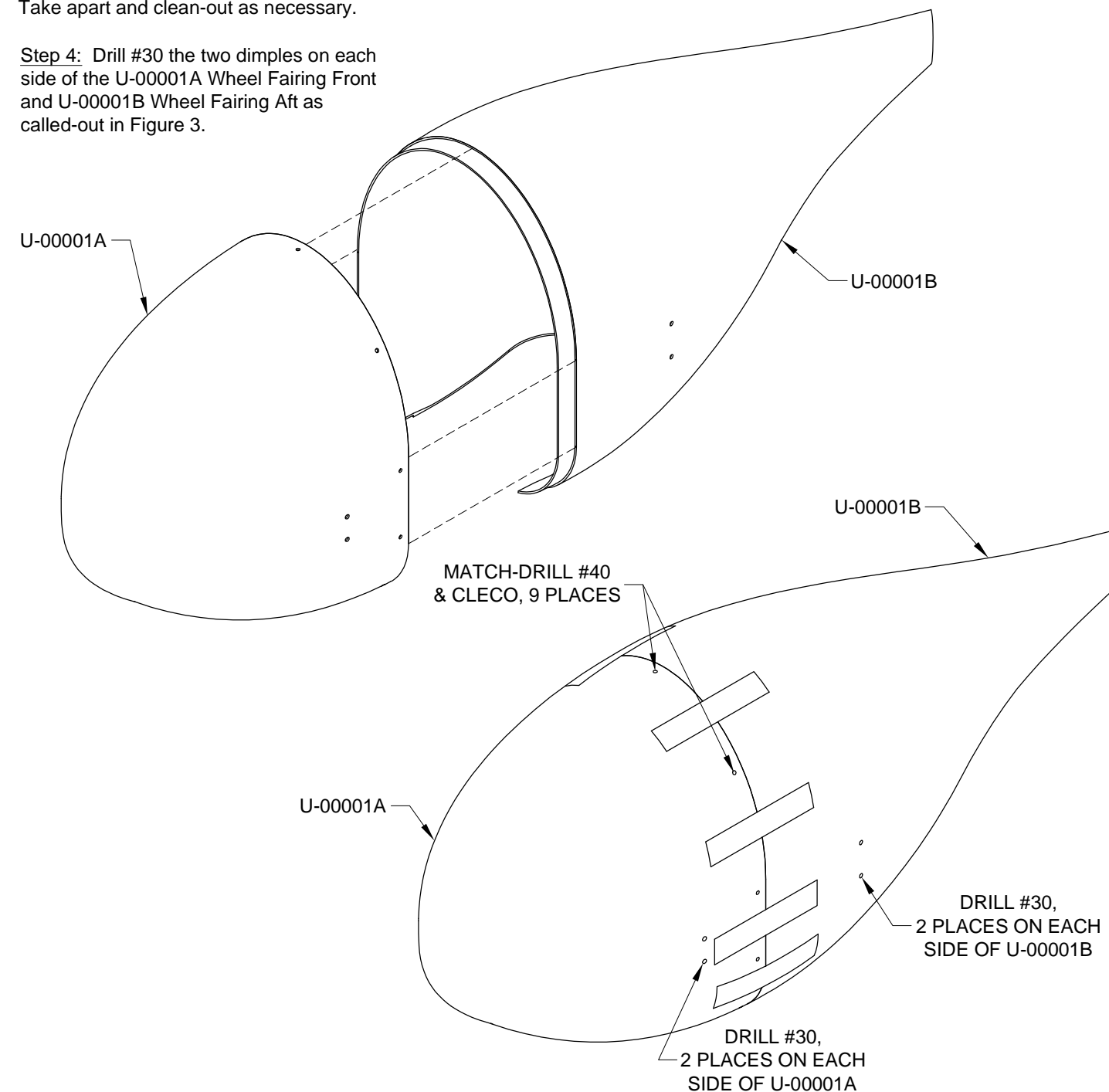
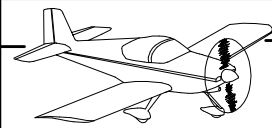

FIGURE 3: JOIN FAIRING HALVES & MATCH-DRILL



NOTE: Illustration shows left side installation only, when modifying the right wheel fairings make the cutout on the opposite side of the fairings.

Step 1: Use a fine point felt pen to mark gear leg opening on the U-00001A Wheel Fairing Front and U-00001B Wheel Fairing Aft as shown in Figure 1. Trim to within 1/16 of trim line then sand to finish edge.

Add a radius to wheel fairing aft for brake line clearance as shown in Figure 1.

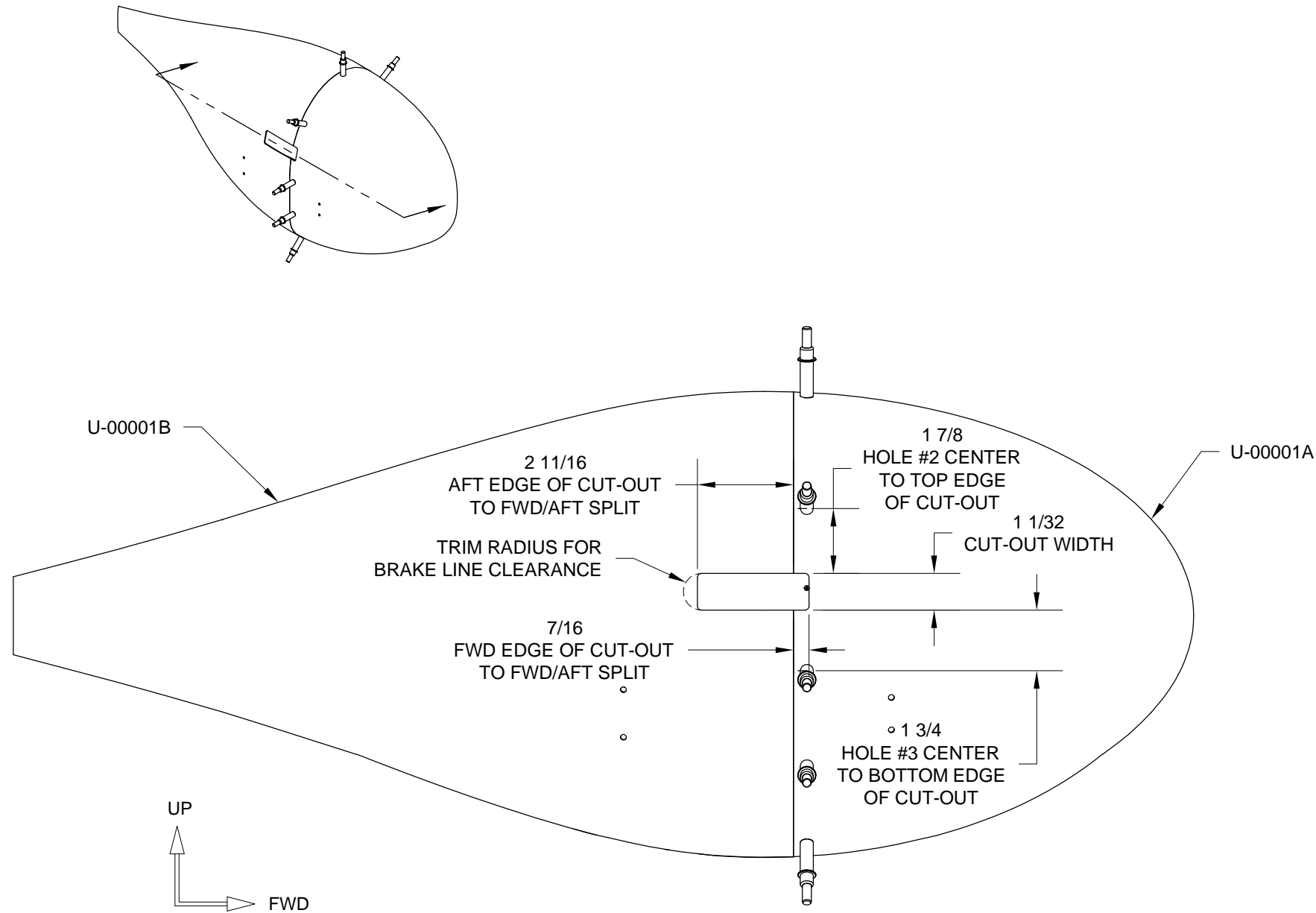
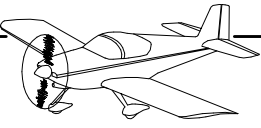

FIGURE 1:
GEAR LEG CLEARANCE HOLE



Step 1: Final-Drill #40 all the 3/32 holes in the 4 U-00002 Wheel Fairing Brackets. See Figure 1.

Machine countersink all the #40 holes in the wheel fairing brackets to fit the head of an AN426AD3 rivet. See Figure 1.

Attach nutplates to the wheel fairing brackets using the rivets called-out in Figure 1.

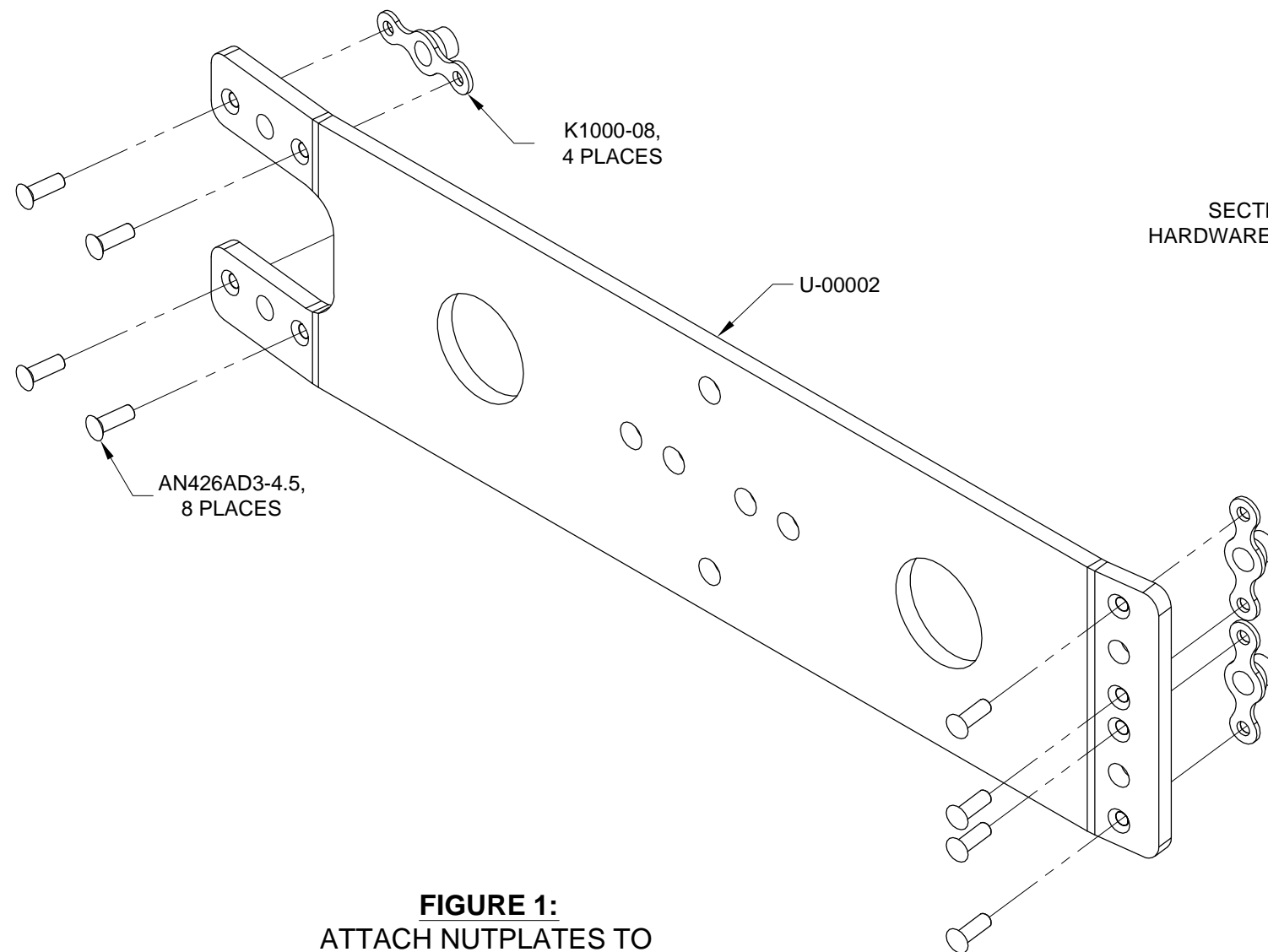

FIGURE 1:
ATTACH NUTPLATES TO
WHEEL FAIRING BRACKETS

NOTE: See Section 35 for information related to initial installation of the wheels and brakes. Specific details pertaining to removal and reinstallation of wheels and brakes will not be repeated in this section.

Step 2: Remove the Main Wheel from the Axle.

Remove the bolts that attach the axle and Brake Plate to the U-1220-L Main Gear Leg.

Discard the two washers that were installed under each axle attach bolt head and reinstall the axle, brake plate, and U-00003 Bracket Mount to the main gear leg. The two holes in the axle must be horizontally aligned when installed as shown in Figure 2.

Step 3: Attach one of the U-00002 Wheel Fairing Brackets to the U-00003 Bracket Mount as shown in Figure 3.

Reinstall the Main Wheel to the Axle.

SEE
SECTION 35 FOR
HARDWARE CALL-OUT

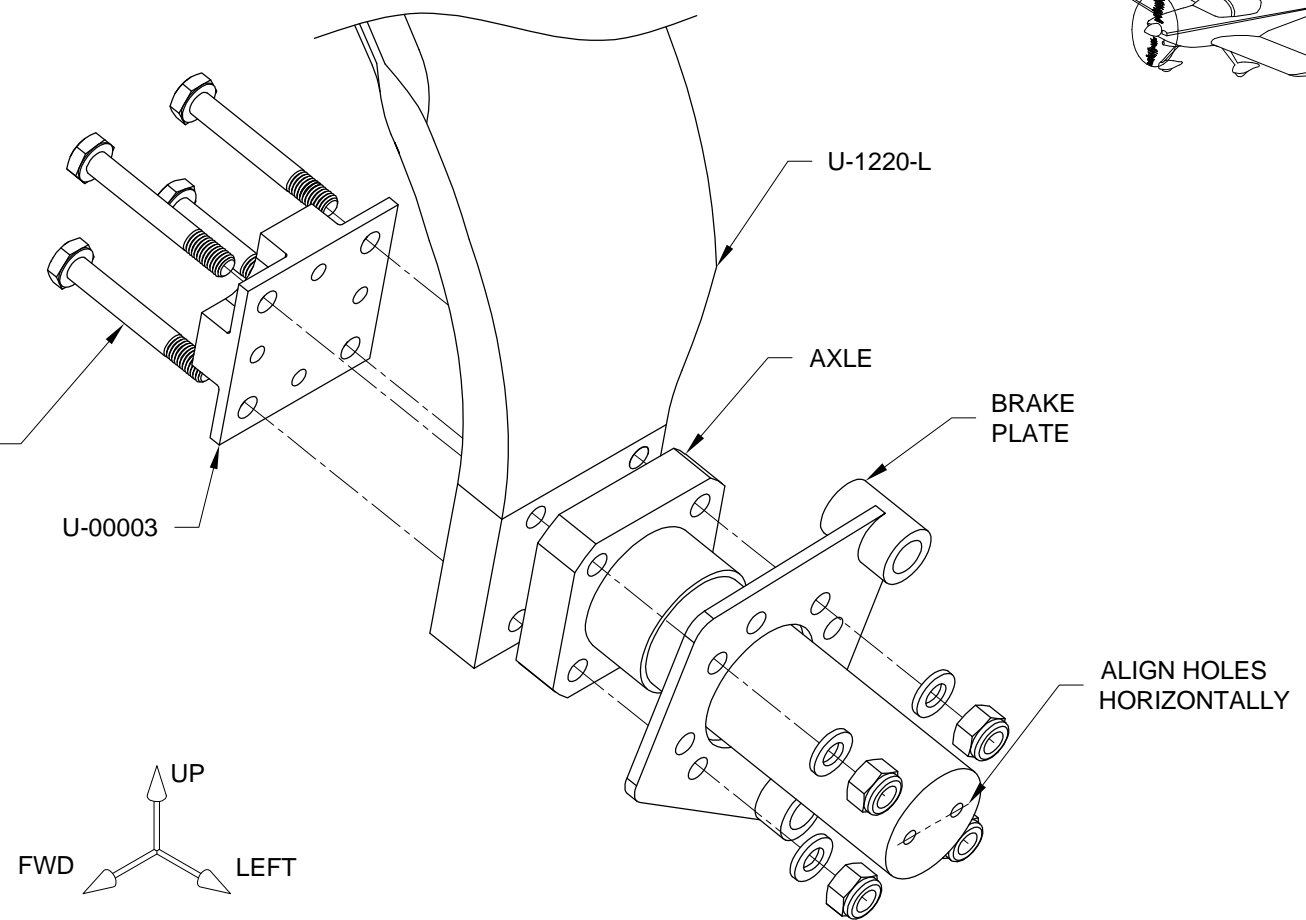

FIGURE 2:
ATTACH BRACKET MOUNT TO MAIN GEAR LEG

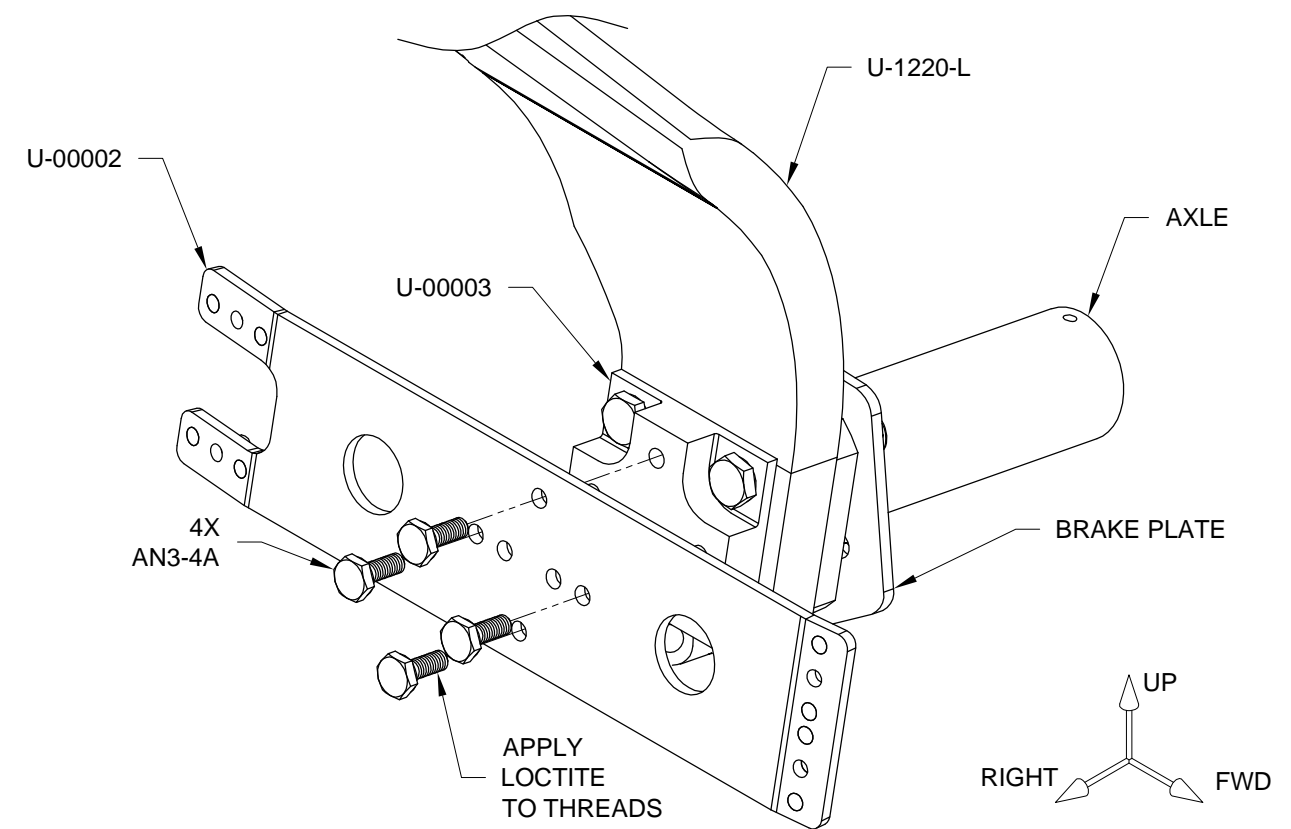

FIGURE 3:
ATTACH INBOARD WHEEL FAIRING BRACKET

Step 1: Attach the U-00004 Bracket Mount and U-00002 Wheel Fairing Bracket to the axle with the hardware called out in Figure 1.

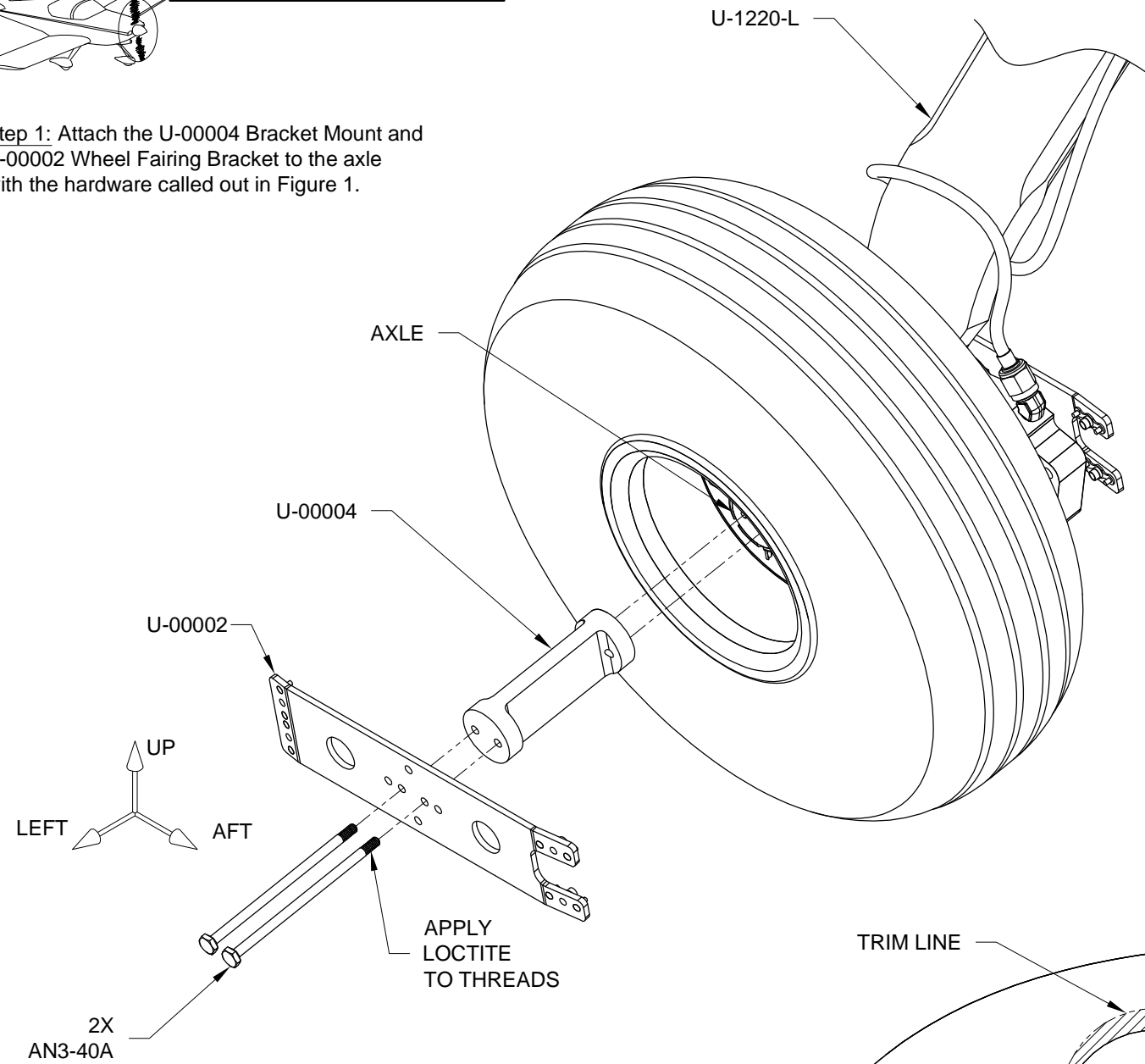

FIGURE 1:
ATTACH BRACKET MOUNT AND
WHEEL FAIRING BRACKET

NOTE: brake line may be gently re-formed by hand to fit inside wheel fairing.

Step 2: Cleco the U-00001B Wheel Fairing Aft on the U-00002 Wheel Fairing Brackets. The clearance on the inboard and outboard side of the wheel opening are different; the inboard clearance is approximately 1/2 inch.

Step 3: With a fine point pen, mark the U-00001B Wheel Fairing Aft along the aft and outboard wheel opening so that the distance is the same as that of the inboard wheel opening. See Figure 2.

Remove the wheel fairing aft and trim to within 1/16 inch of the trim line. Finish to the trim line by sanding. Reinstall the wheel fairing aft on the U-00002 Wheel Fairing Brackets.

Step 4: Cleco the U-00001A Wheel Fairing Front to the U-00002 Wheel Fairing Brackets and the U-00001B Wheel Fairing Aft as shown in Figure 2.

Use a fine point pen to mark the wheel fairing front on the outboard side where it meets the wheel fairing aft wheel opening. Continue marking along the outboard side and front of the wheel opening to create the approximately 1/2 inch wheel clearance.

Remove the wheel fairing front and trim to within 1/16 inch of the trim line. Finish to the trim line by sanding. Reinstall wheel fairing front and check that the wheel openings allow proper tire clearance. See Figure 2.

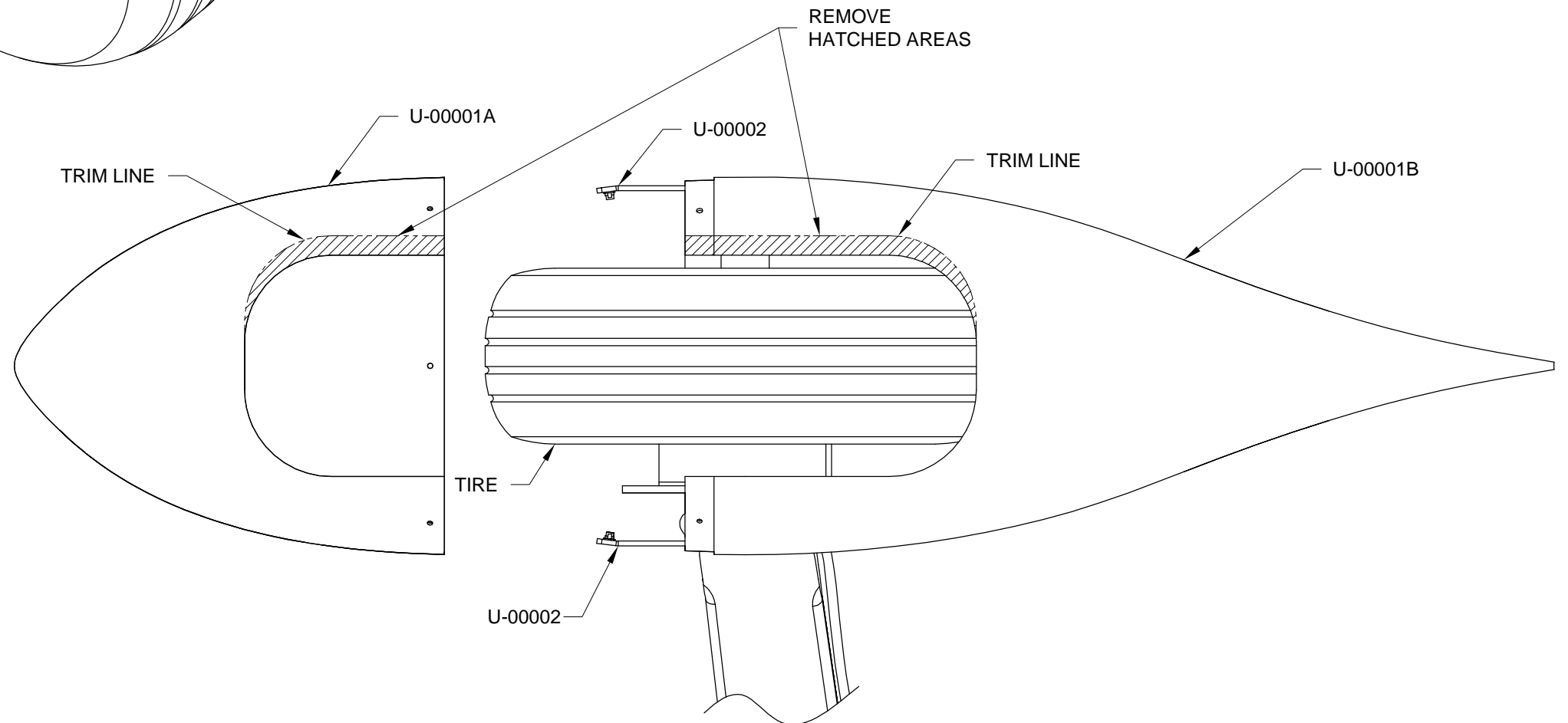
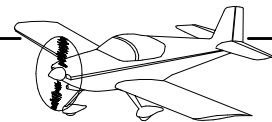

FIGURE 2:
MODIFYING WHEEL FAIRING HALVES



Step 1: Final-drill #19 the U-00001B Wheel Fairing Aft and the U-00001A Wheel Fairing Front to the U-00002 Wheel Fairing Brackets. Avoid drilling into the nutplates mounted on the wheel fairing brackets. See Figure 1. Remove clecos and wheel fairings.

Step 2: Aggressively roughen the inside of the U-00001A Wheel Fairing Front and U-00001B Wheel Fairing Aft at the #19 screw locations. Clean.

Coat the threads of the 8-32 screws (called out in Figure 2) with wax to prevent epoxy from bonding to them. Tape the U-00002 Wheel Fairing Bracket tabs to prevent the epoxy/flox mixture from bonding to them.

Mix epoxy and floc (cotton or glass) to the consistency of peanut butter and build up the areas around the four screws on both the forward and aft main wheel fairings. Apply enough epoxy mixture (approximately 1/16 of an inch) to create a recess when the brackets are pressed against them, but not so much that the epoxy will capture the brackets. See Figure 1 Section A-A.

Attach the wheel fairings to the brackets and to each other while the mixture is wet. Do not tighten the screws. Leave 1/16 protruding above the surface of the fairing.

Final-Drill #19 the screw holes again to remove any floc mixture.

Step 3: Final-Drill #27 three (of the nine) evenly spaced #40 screw attach holes in the U-00001A Wheel Fairing Front and U-00001B Wheel Fairing Aft as shown in Figure 1. Remove the wheel fairing front and wheel fairing aft when the epoxy has fully cured.

NOTE: To locate the nutplate rivet holes the nutplate is held in place with a mounting screw and the nutplate is used as a drill template. Cleco the first rivet hole to prevent the nutplate from rotating while locating the second rivet hole. It is important on curved surfaces that the nutplate is match-drilled from the side of the part on which it will later be installed.

NOTE: Machine countersinks into fiberglass that are up to .005 too shallow are acceptable, even preferable, to countersinks which are too deep. Rivets should be slightly under set where installed in fiberglass parts.

Step 4: Install nutplates at the three #27 holes drilled in Step 4. Final-Drill #40 and countersink the U-00001B Wheel Fairing Aft for nutplate rivets as shown in Figure 1. Deburr the holes. Rivet the nutplates to the wheel fairing aft as per the callouts.

Step 5: Reassemble the U-00001A Wheel Fairing Front and U-00001B Wheel Fairing Aft using three #6 screws and clecos at the rest of the holes. Final-Drill #27 the remainder of the #40 holes. Disassemble the wheel fairing halves. Install the remaining nutplates.

Countersink the #27 holes in the wheel fairing front as per the callout in Figure 2.

Step 6: Mount the U-00001B Wheel Fairing Aft and U-00001A Wheel Fairing Front to the U-00002 Wheel Fairing Brackets using the hardware called out in Figure 2. Use the screws called out in Figure 2 to attach the wheel fairing halves together.

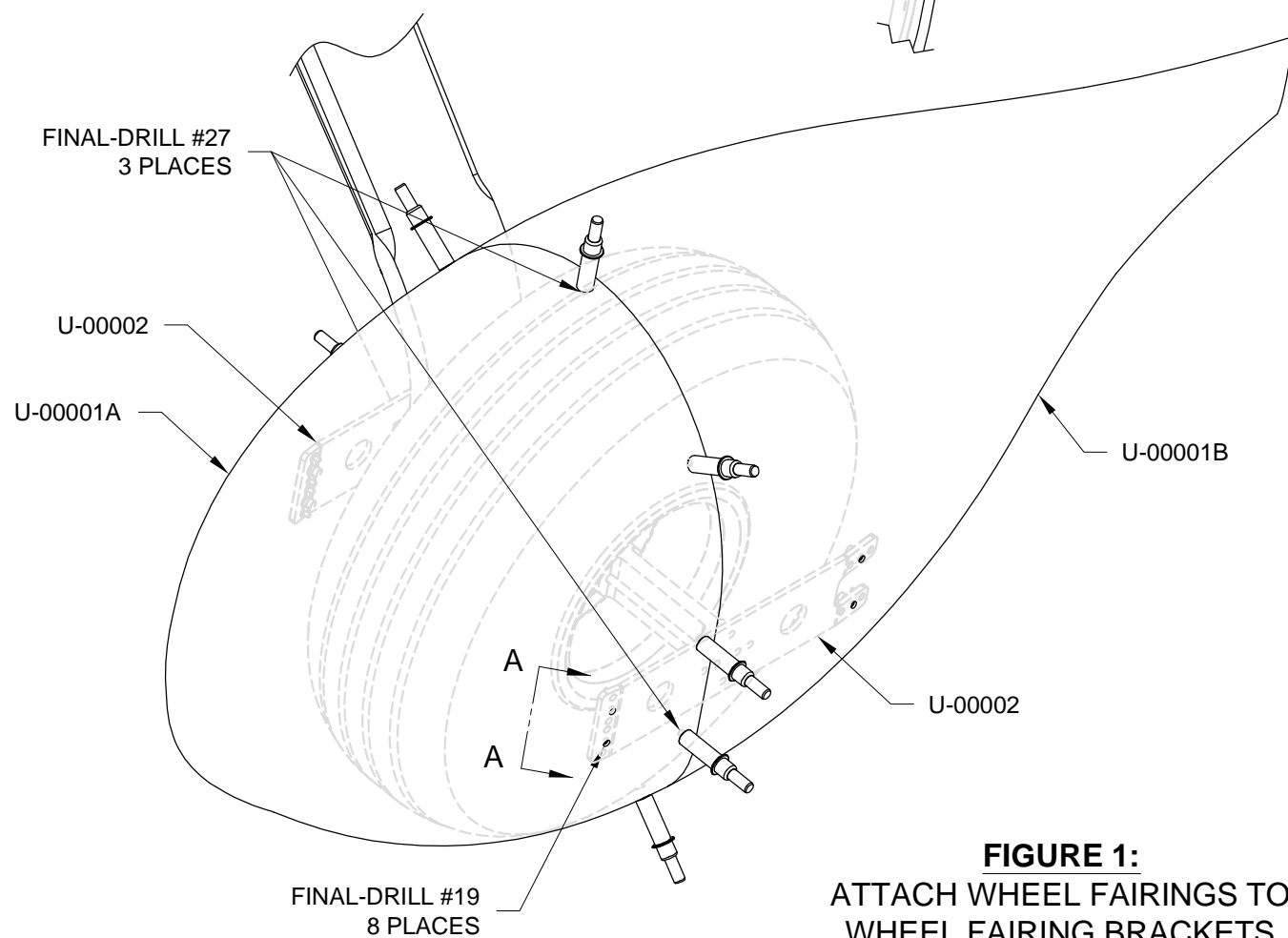
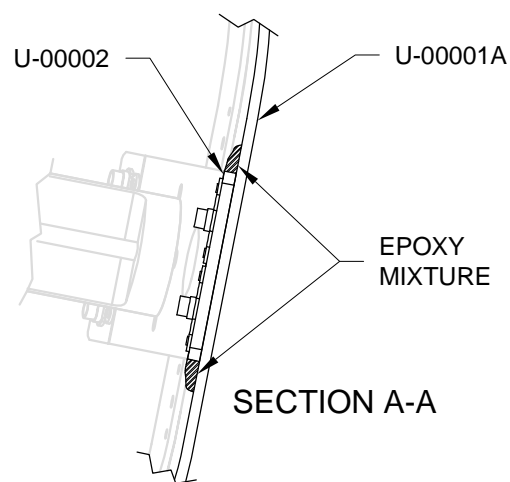

FIGURE 1:
ATTACH WHEEL FAIRINGS TO
WHEEL FAIRING BRACKETS

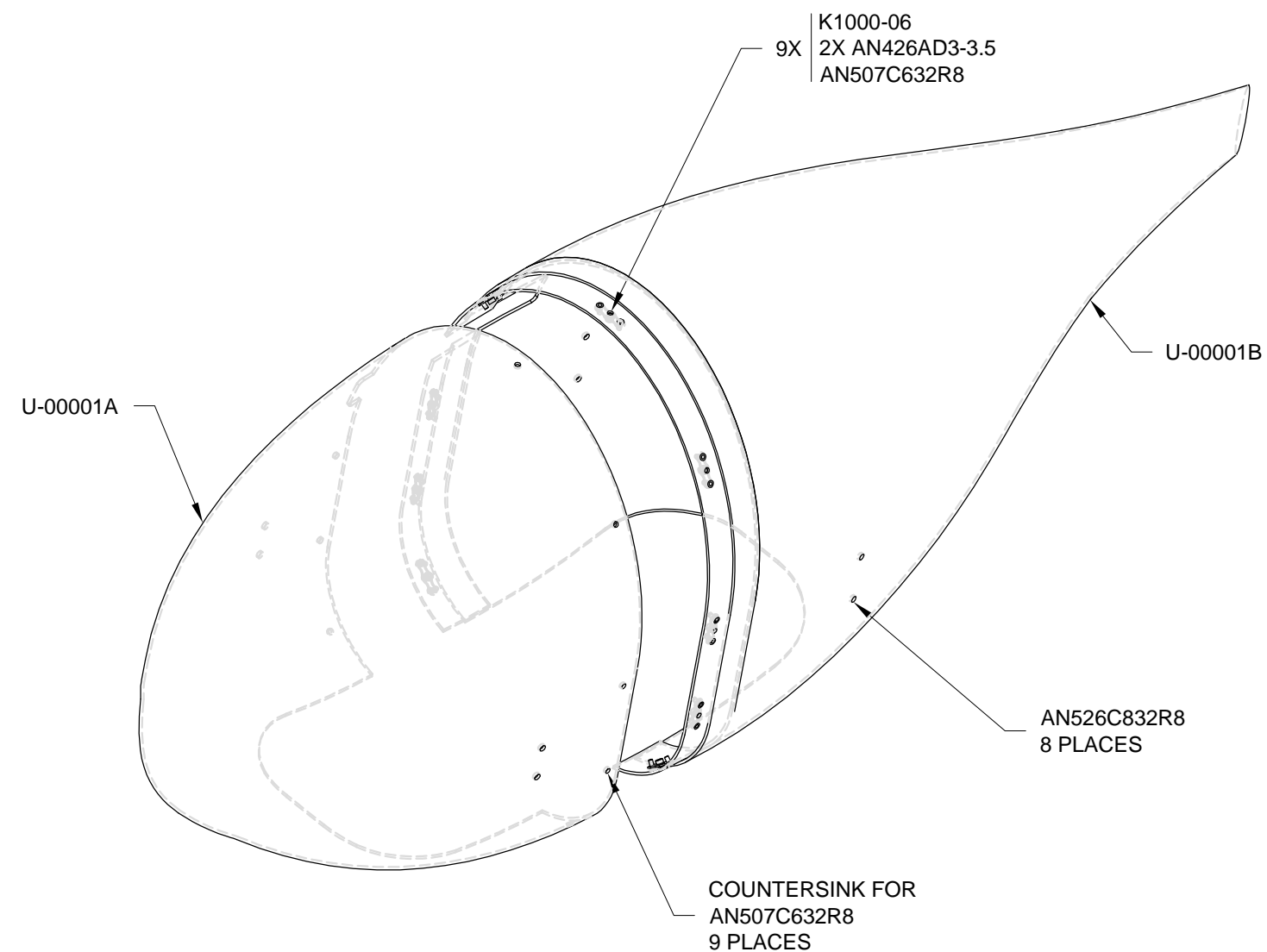
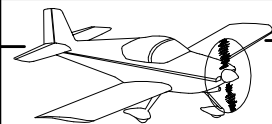

FIGURE 2:
ATTACH WHEEL FAIRINGS
TO EACH OTHER



Step 1: Remove material up to the scribe lines on both the U-00005A Wheel Fairing Front and U-00005B Wheel Fairing Aft.

Use a 3/4 inch step drill to remove the hatched areas on each side of the wheel fairing front. Center the drill on the dimples as shown in Figure 1.

Check the inside of the wheel fairing front and aft in the areas where the parts are dimpled by running a finger over the interior surface. If there are thick spots, or bumps in the fiberglass, sand them down to make a uniform surface.

Step 2: Drill #40 the dimples in the U-00005A Wheel Fairing Front in six places as shown in Figure 1. Take care that the drill is held perpendicular to the surface.

Step 3: Holding the drill perpendicular to the surface, drill #40 the dimples in the U-00005B Wheel Fairing Aft as shown in Figure 1.

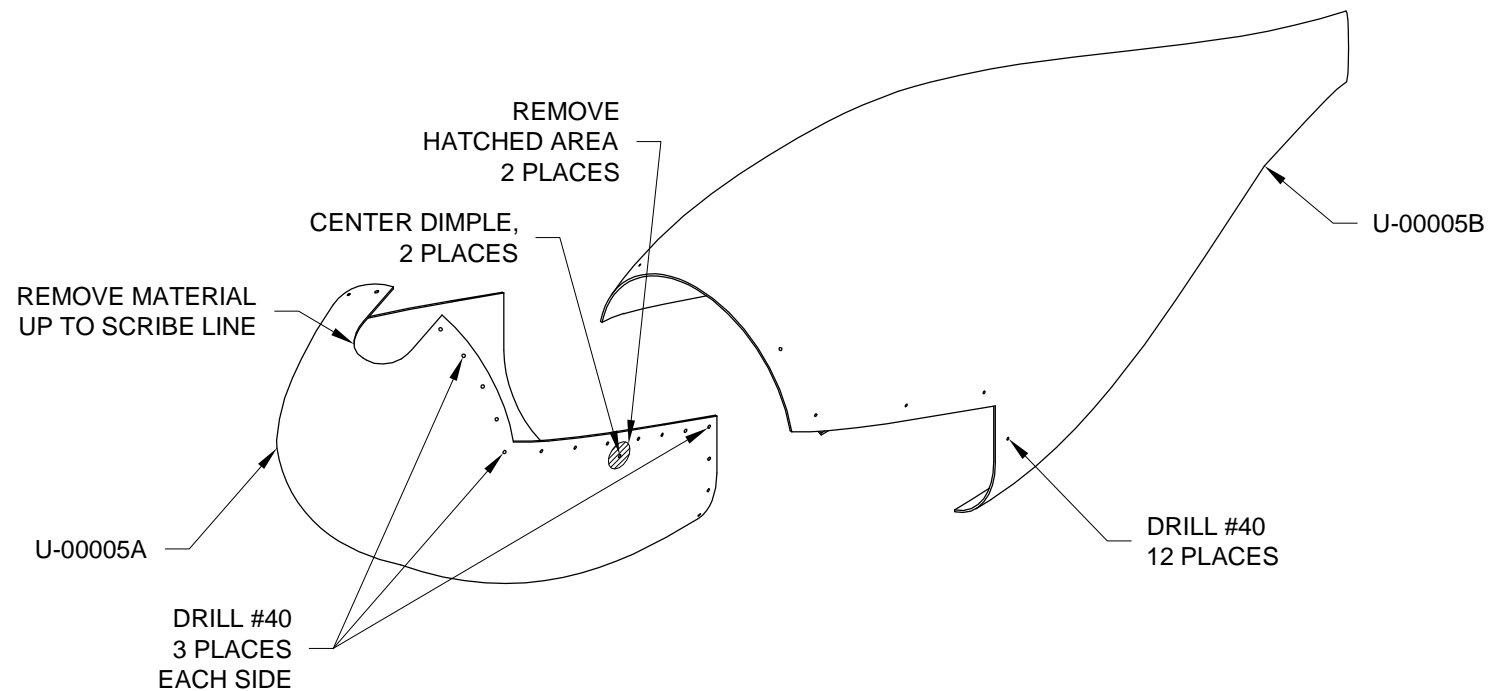

FIGURE 1: TRIMMING WHEEL FAIRING HALVES

Step 4: Remove the hatched area from the U-00006A-1 Wheel Fairing Bracket to create the U-00006A-L-1 and U-00006A-R-1 Wheel Fairing Brackets as shown in Figure 2.

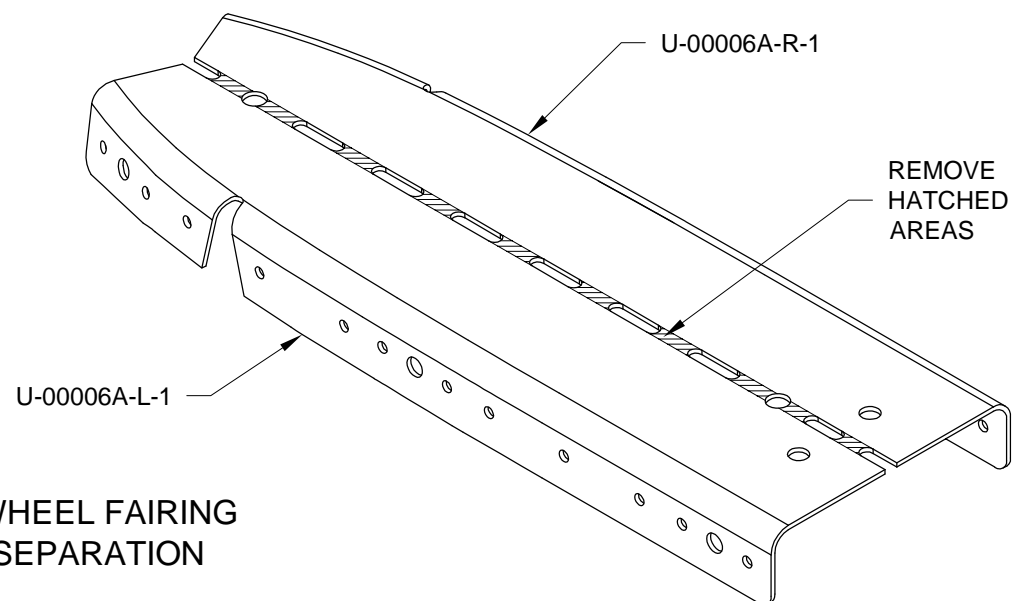

FIGURE 2: WHEEL FAIRING BRACKET SEPARATION

Step 5: Bend the U-00006B Splice Strips so that they fit the interior shape of the U-00005A Wheel Fairing Front. A close fit is desired. See Figure 3.

Step 6: Cleco the U-00006B Splice Strips to the inside of the U-00005A Wheel Fairing Front as shown in Figure 3. Match-Drill #40 and cleco the rivet attach holes between the nose wheel fairing and the splice strip. Clean debris as required.

Machine countersink holes in the wheel fairing front for the head of an AN426AD3 rivet.

NOTE: Use a 1 inch step drill (if available) to finish the 3/4 holes drilled in Step 1.

Step 7: Finish the holes drilled in the U-00005A Wheel Fairing Front in Step 1 to the finish diameter shown in Figure 3.

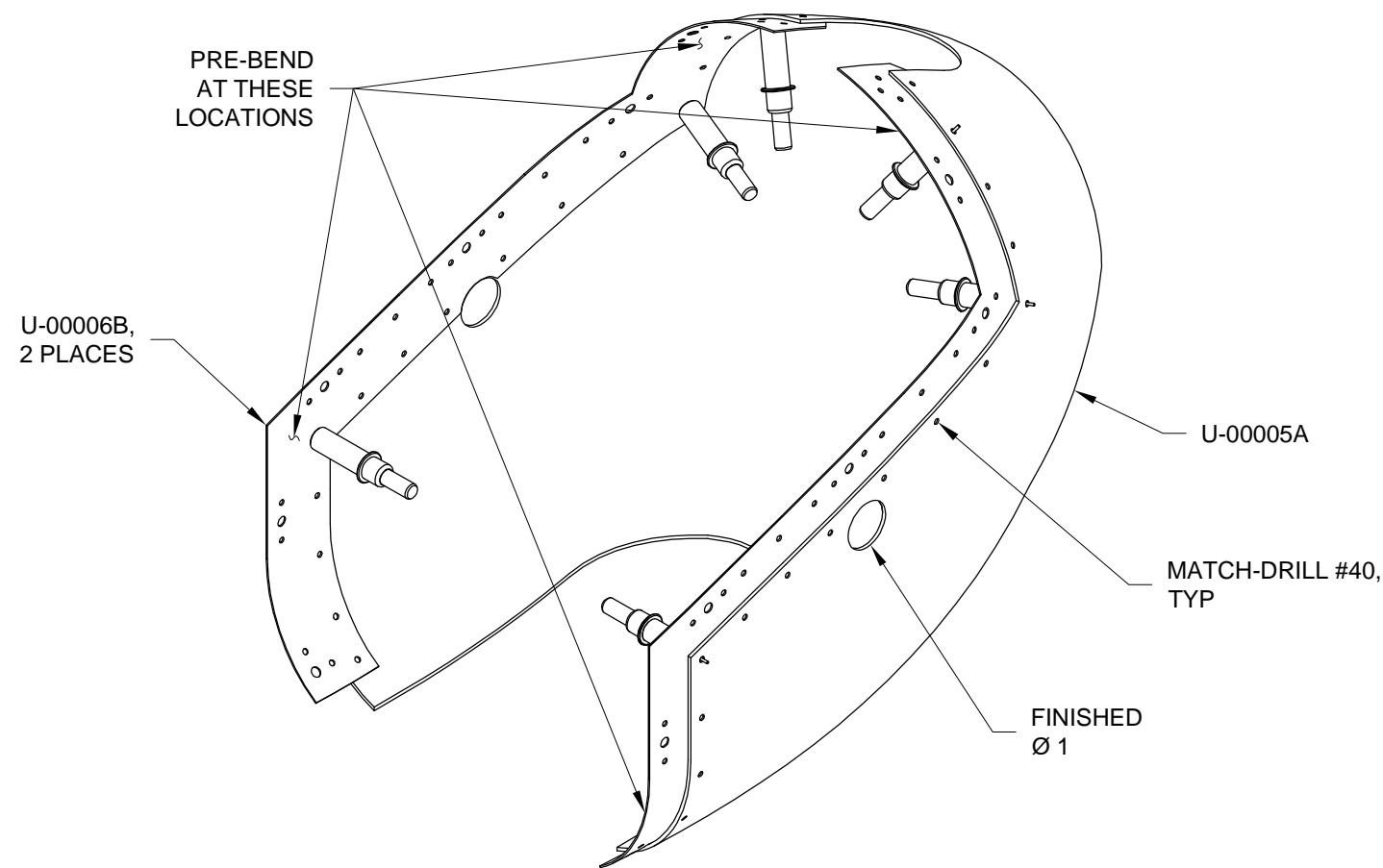
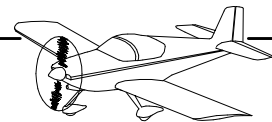

FIGURE 3: FITTING SPLICE STRIPS AND WHEEL FAIRING FRONT



Step 1: Cleco the U-00005B Wheel Fairing Aft to the U-00006B Splice Strips and check fit. The parts fit together well when there is no strain or interference between the parts.

With the wheel fairing halves and splice strips clecoed together from the inside, the parts may be repositioned slightly. Make any additional adjustments to the fit by sanding the edges of the wheel fairing and forming the splice strips with smooth jawed and/or fluting pliers. See Figure 1.

Step 2: Final-Drill #19, using the #19 holes in the U-00006B Splice Strips as drill guides wherever possible, the #40 holes in the U-00005B Wheel Fairing Aft as shown in Figure 1. Secure the drilled holes with 8-32 screws and nuts to prevent the parts from shifting while drilling the next hole.

Match-Drill #19 the two top screw holes in the wheel fairing aft from the holes in the Splice Strips. See Figure 1.

Step 3: Cleco U-00006A-1 Wheel Fairing Brackets to the U-00006B Splice Strips as shown in Figure 2. The forward flanges of the wheel fairing brackets need to be adjusted slightly by hand for a good fit.

Final-Drill #27 All screw hole locations between the splice strips and wheel fairing brackets.

Final-Drill #40 all remaining 3/32 hole locations in the splice strips and wheel fairing brackets. Remove wheel fairing brackets.

Dimple all nutplate attachment hole locations and the rivet hole locations common to the splice strips and the wheel fairing brackets. Dimple rivet holes in the corresponding nutplates. See Figures 1 and 2.

Step 4: With the U-00006B Splice Strips still clecoed to the U-00005A Wheel Fairing Front, carefully apply masking tape to the splice strip, following the edge of the nose wheel fairing front. Tape the entire length of the intersection between the parts.

Step 5: Remove the clecoes and the U-00006B Splice Strips. Aggressively roughen the surface area on each part where the two overlap with 80 grit sandpaper. Leaving the tape in place, clean the parts.

Mix epoxy and floc (cotton or glass) to the consistency of peanut butter and smear a thin coating along the roughened surface of the U-00006B Splice Strips.

Step 6: While the epoxy mixture is still wet, cleco then rivet the U-00006B Splice Strips to the U-00005A Wheel Fairing Front with the rivets called out in Figure 1.

With a popsicle stick, remove any excess epoxy mixture that has squeezed out between the parts. Remove masking tape. Allow epoxy to cure.

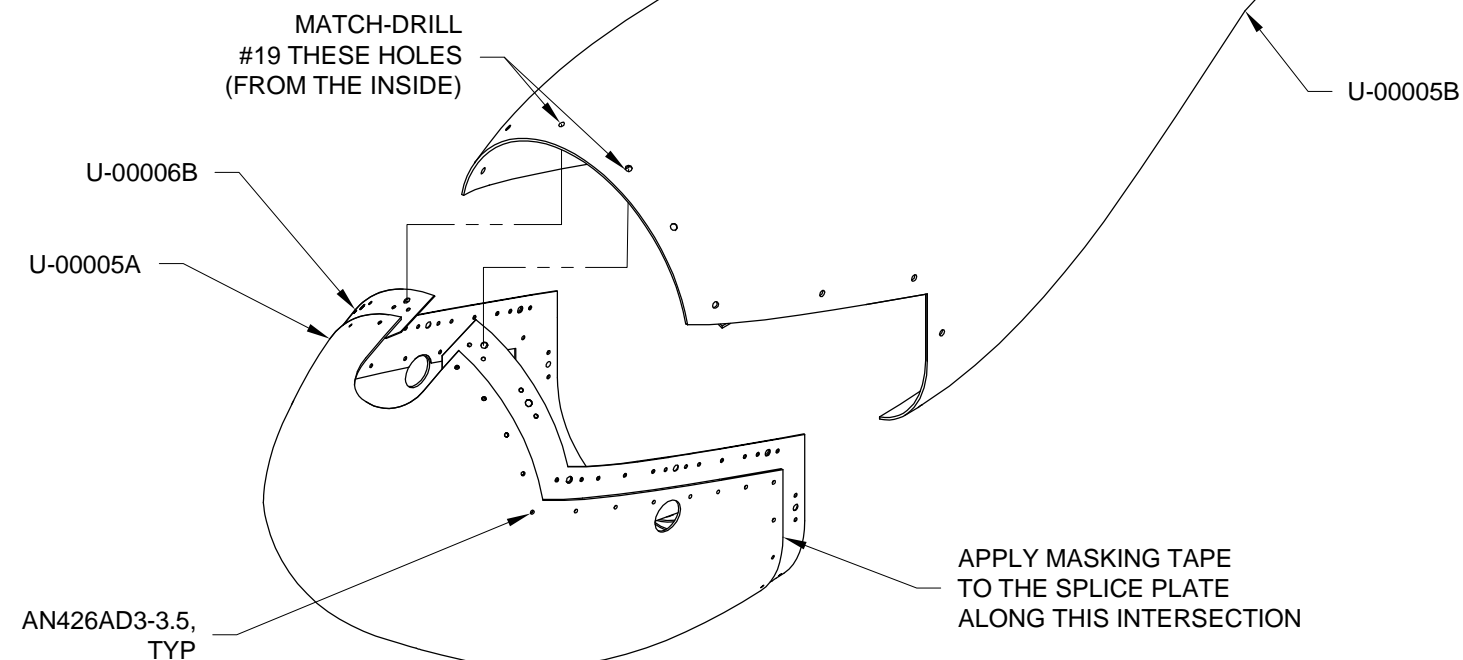

FIGURE 1: RIVETING SPLICE STRIPS TO THE WHEEL FAIRING FRONT

NOTE: Nutplates installed in tight radius areas will fit better if pre-bent.

Step 7: Cleco then rivet the U-00006A-1 Wheel Fairing Brackets to the U-00006B Splice Strips. Install the nutplates called out in Figure 2.

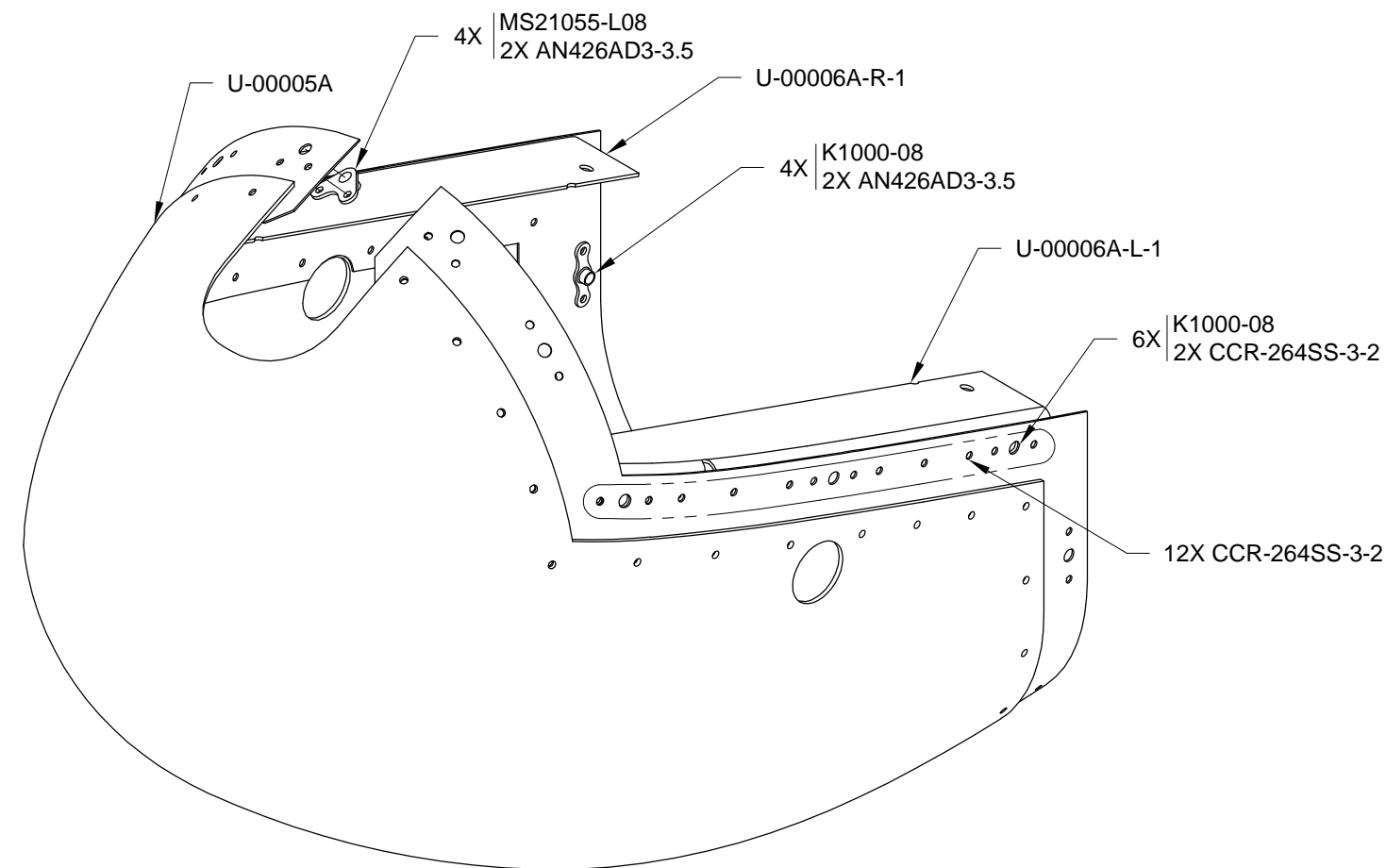

FIGURE 2: RIVETING WHEEL FAIRING BRACKETS AND NUTPLATES TO THE WHEEL FAIRING FRONT

Step 1: Secure the U-00006C-1 Drill Template to the U-00006A-L-1 and U-00006A-R-1 Wheel Fairing Brackets with #8 screws and nuts as shown in Figure 1.

Step 2: Attach the U-00005B Wheel Fairing Aft to the U-00006B Splice Strips. Clamp the drill template to the wheel fairing brackets. Use a fine point felt pen to mark the drill template along the intersection between the drill template and the wheel fairing brackets. See Figure 2.

Remove the nose wheel fairing aft.

Step 3: Check that the drill template is still aligned properly with the wheel fairing brackets by checking the alignment marks made in Step 2. Match-Drill #19 the drill template to the wheel fairing brackets. See Figure 1.

Remove the drill template and deburr the wheel fairing brackets.

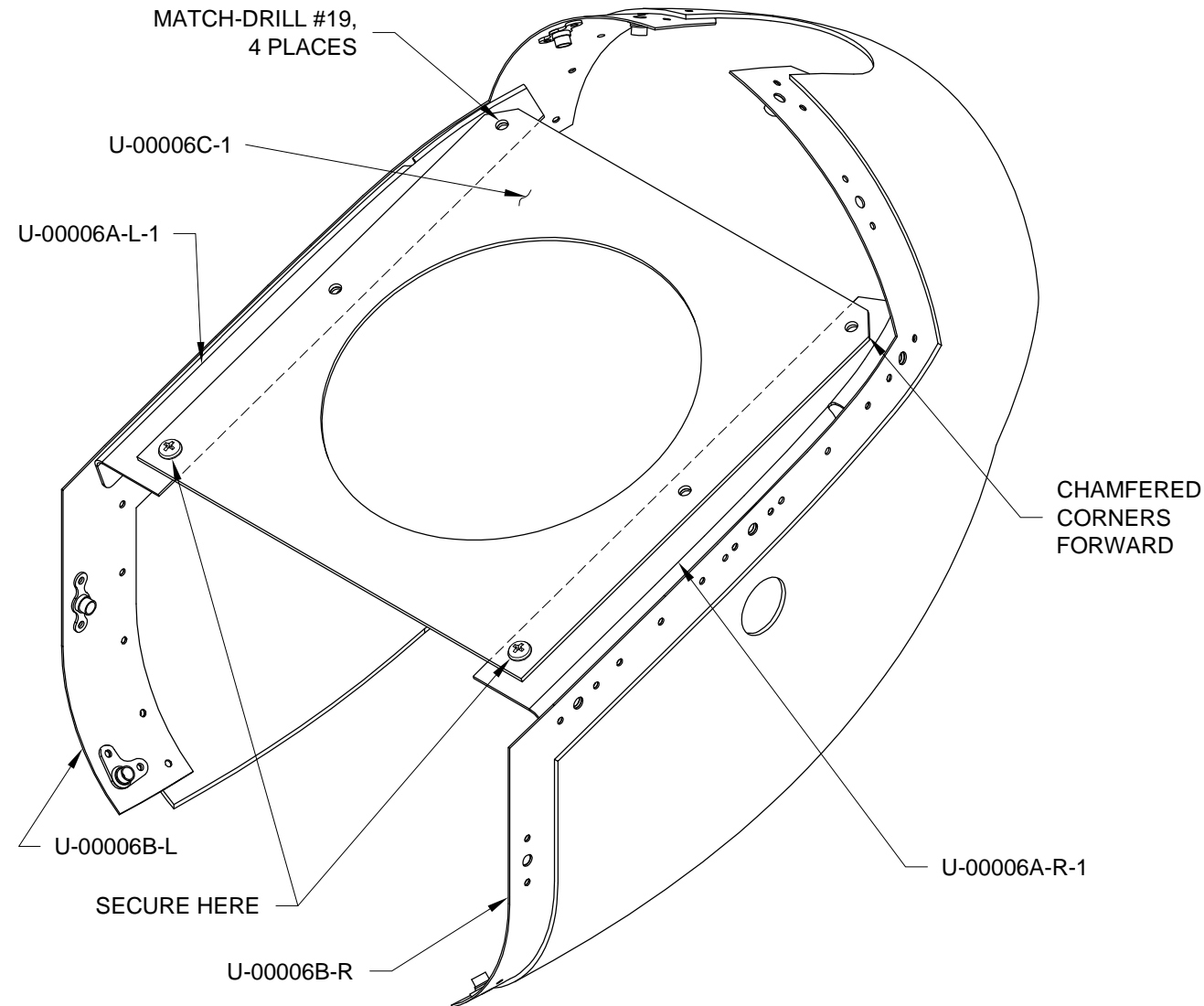

FIGURE 1: POSITIONING THE DRILL TEMPLATE

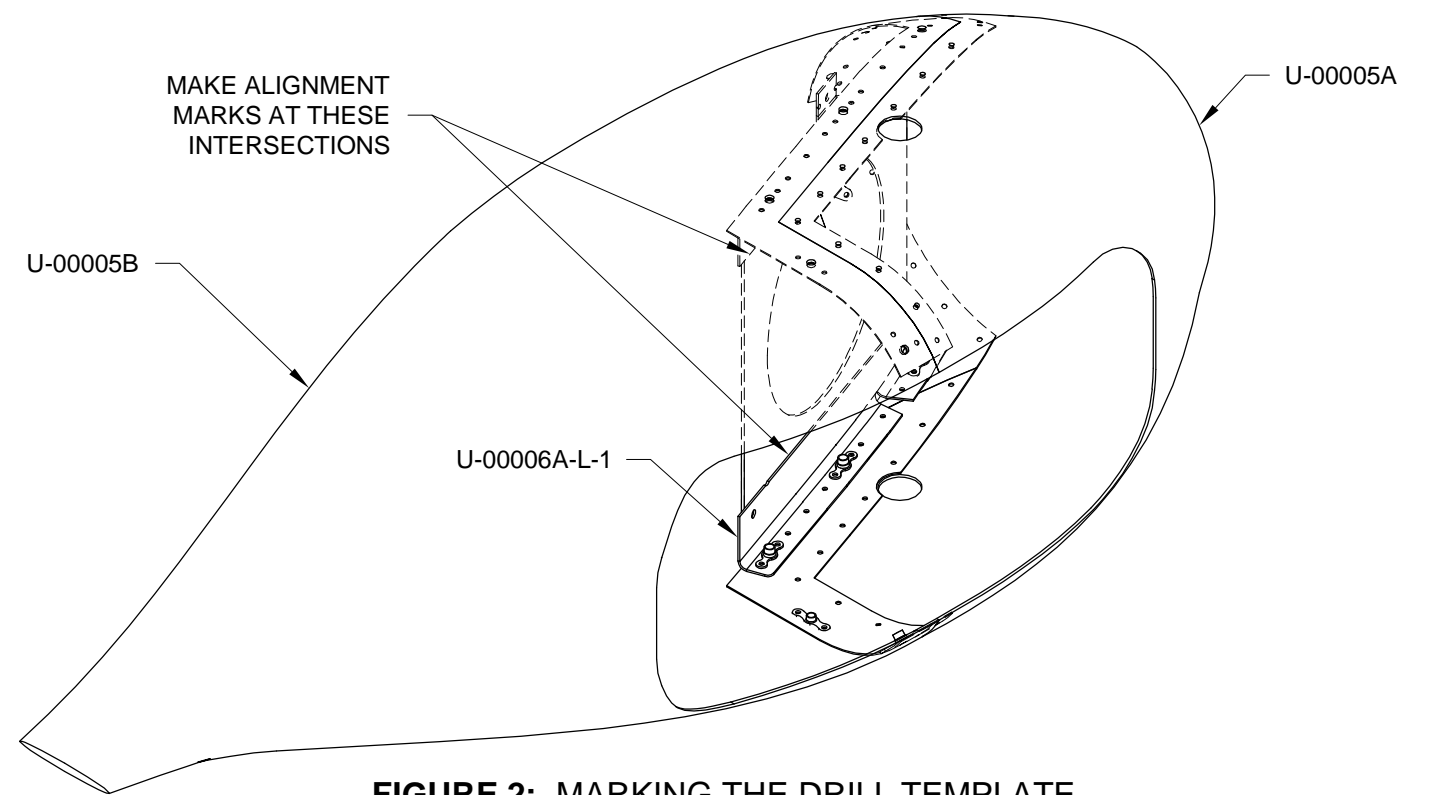

FIGURE 2: MARKING THE DRILL TEMPLATE

Step 4: Secure the U-00006D-1 Doubler Plates to the wheel fairing brackets with #8 screws and nuts as shown for the U-00006A-R-1 in Figure 3.

Match-Drill #40 the doubler plates to the wheel fairing brackets.

Disassemble and deburr.

Dimple all #40 rivet holes in the wheel fairing brackets.

Machine countersink the doubler plates to fit the dimples in the brackets.

Rivet the doubler plates to the wheel fairing brackets using the rivets called out in Figure 3.

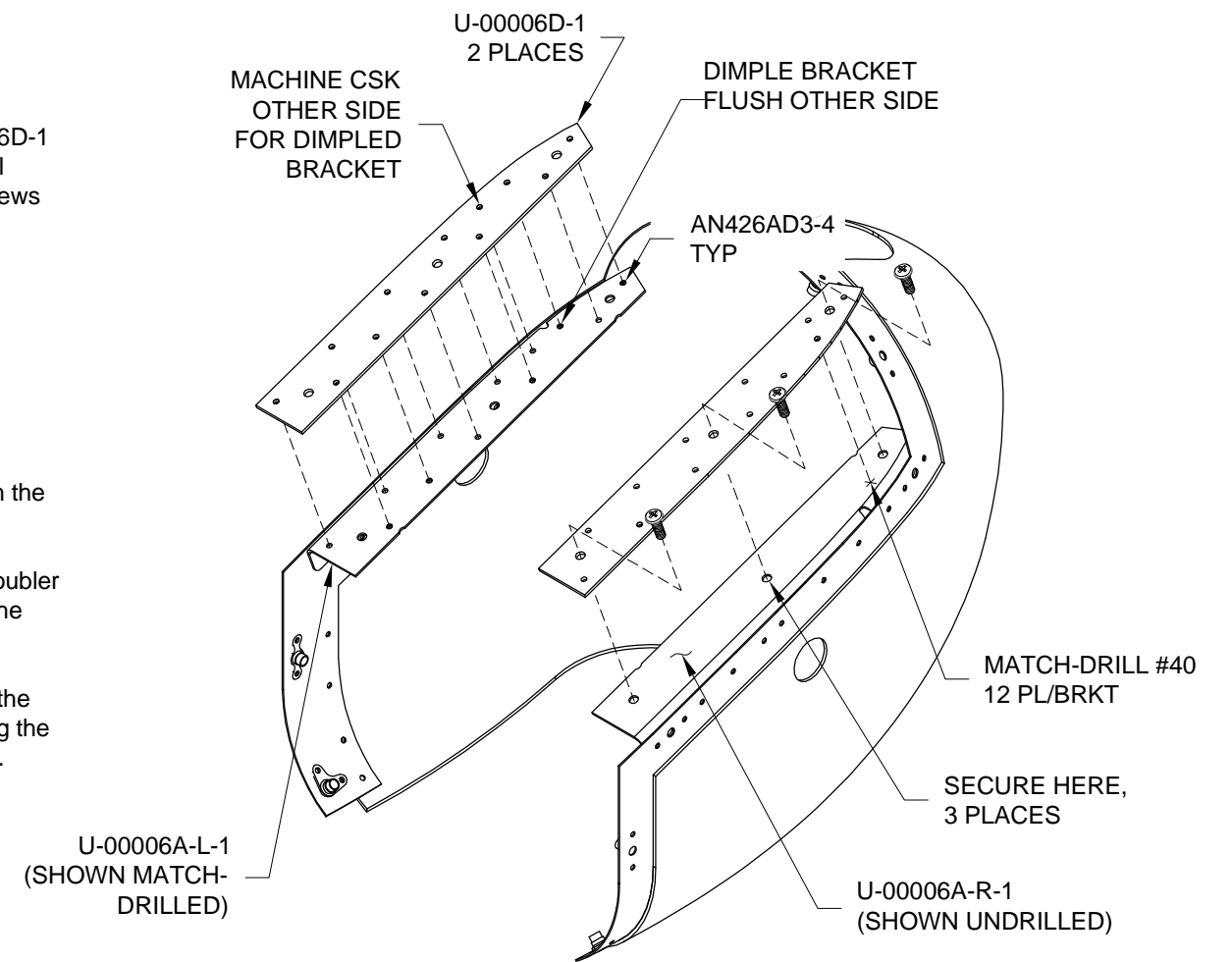

FIGURE 3: INSTALLING THE DOUBLER PLATES



Step 1: Remove the Nose Wheel Assembly from the WD-01230-1 Nose Fork.

Step 2: Remove the hatched areas from U-00006E-1 Fairing Bracket Mount to create U-00006E-L-1 and U-00006E-R-1 Fairing Bracket Mounts.

Machine countersink all nutplate attach holes on the fairing bracket mounts to fit the head of an AN426AD3 rivet.

Rivet both fairing bracket mounts to the nose fork using the rivets called out in Figure 2.

Rivet the nutplates called out in Figure 2 onto both fairing bracket mounts.

Step 3: Reinstall the Nose Wheel Assembly to the nose fork as per instructions in Section 35.

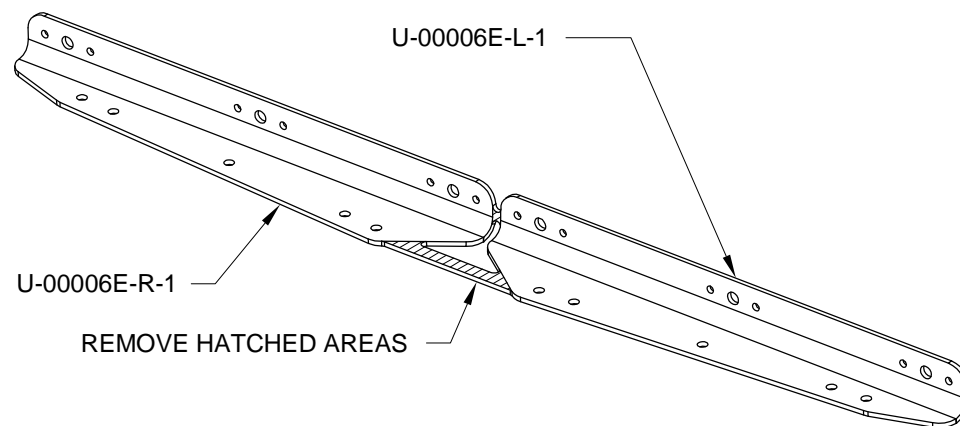

FIGURE 1: SEPARATING THE FAIRING BRACKET MOUNTS

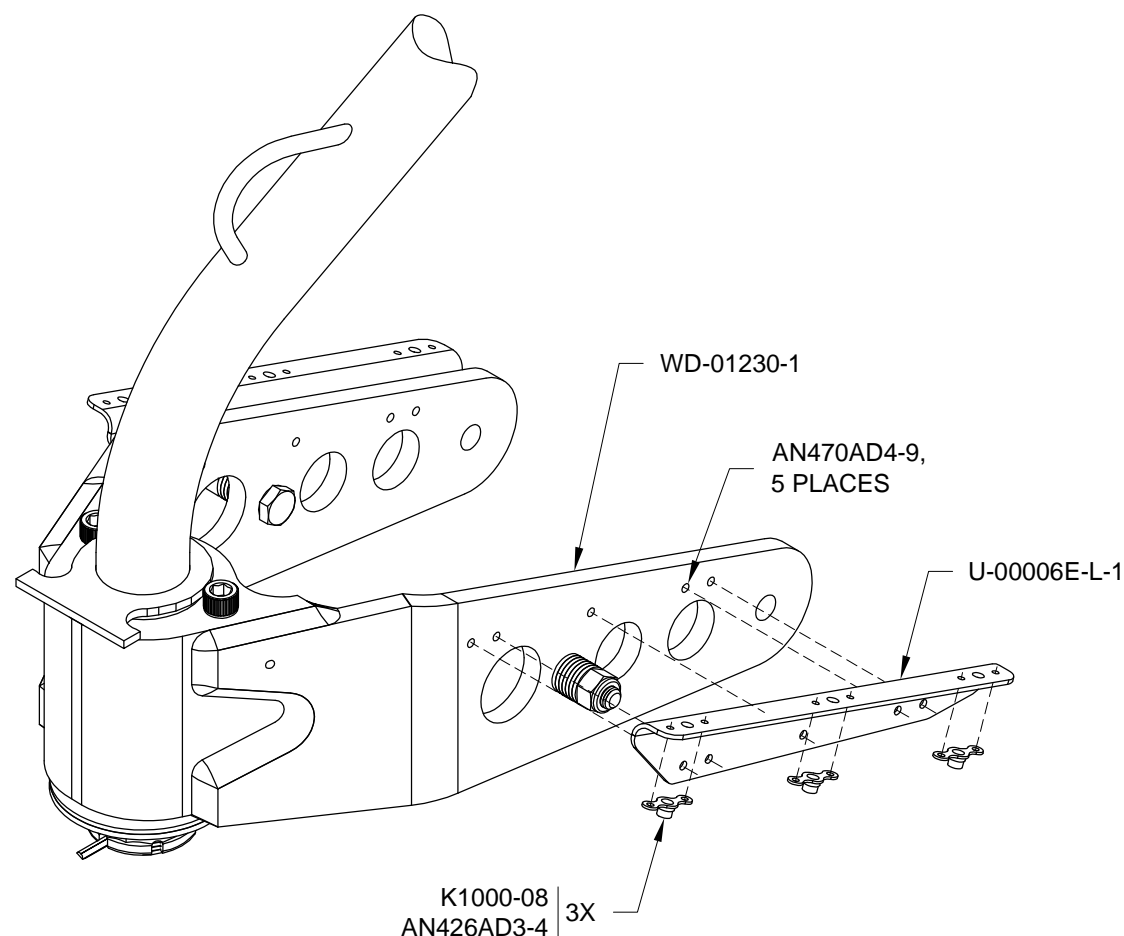

FIGURE 2: ATTACHING THE FAIRING MOUNT BRACKETS

Step 4: Install the U-00005A Wheel Fairing Front and U-00005B Wheel Fairing Aft on the WD-01230-1 Nose Fork as shown in Figure 3. Check that there is a minimum clearance of 1/8 inch between the wheel fairing front and the WD-1201 Gear Leg Assembly.

Verify a minimum clearance of 1/2 inch between the wheel fairing halves and the tire.

Step 5: Remove the U-00005A Wheel Fairing Front and U-00005B Wheel Fairing Aft from the WD-01230-1 Nose Fork .

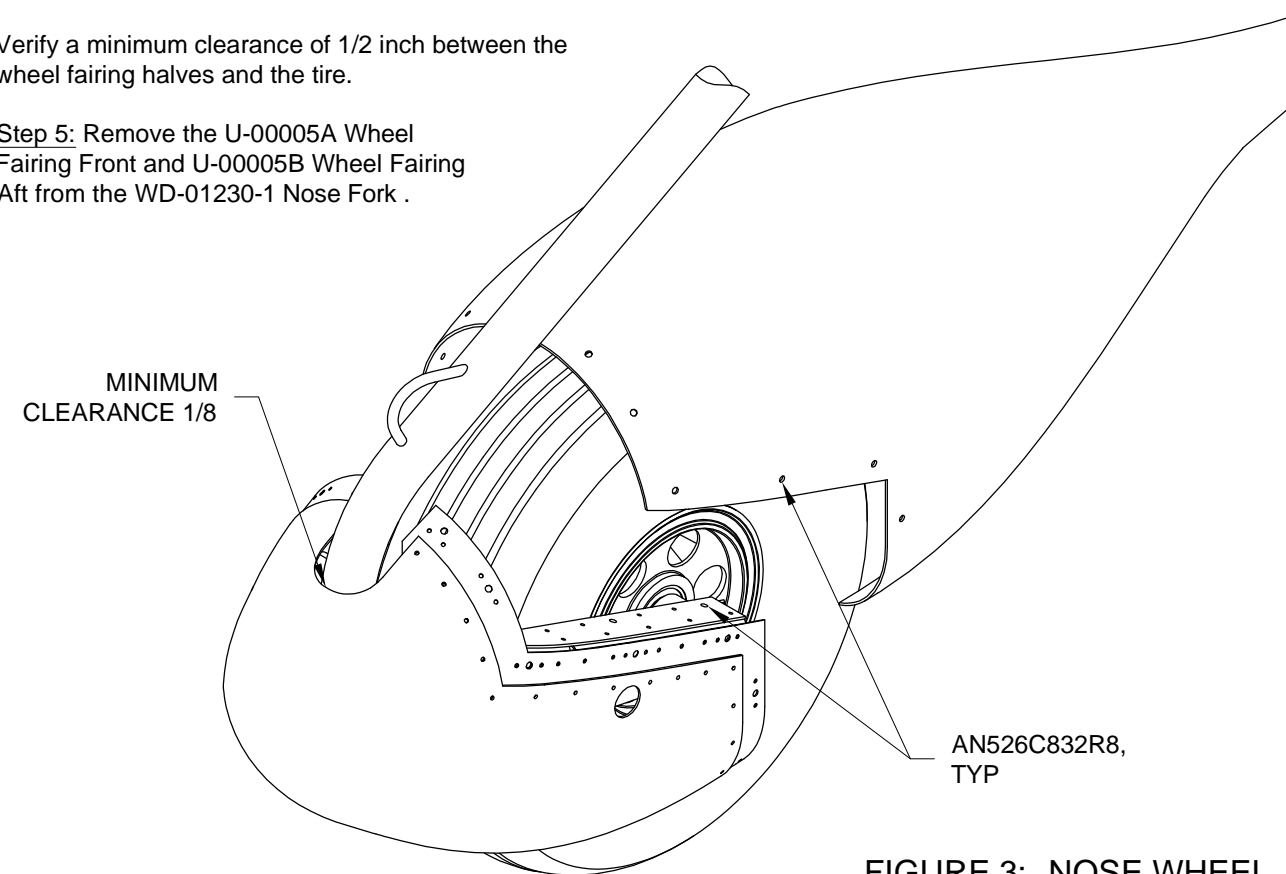

FIGURE 3: NOSE WHEEL FAIRING INSTALLATION

Step 6: Drill #40 multiple places inside the scribe line on the forward surface of the U-00007 Nose Leg Fairing to create an opening for the WD-1201 Gear Leg Assembly winch lug as shown in Figure 4. Finish up to the scribe line with a file and sandpaper.

Trim the nose leg fairing to the scribe lines. See Figure 4.

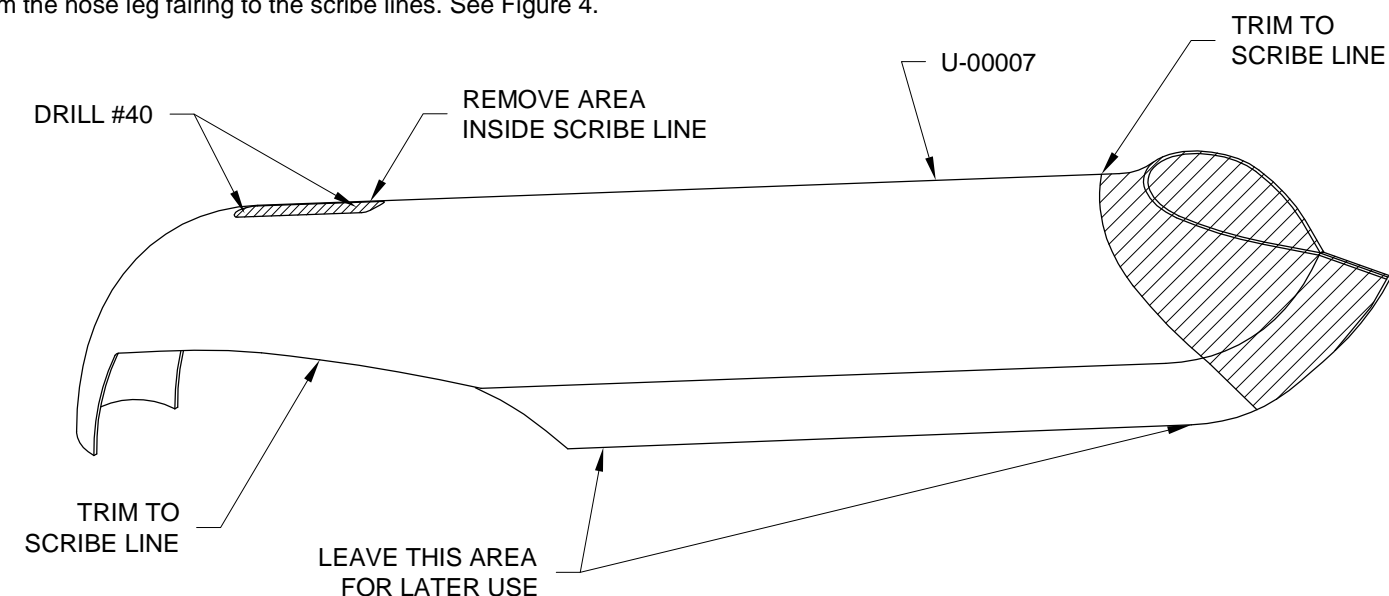

FIGURE 4: NOSE LEG FAIRING TRIM

NOTE: Aircraft should be fairly level side to side during the fitting of the U-00007 Nose Leg Fairing to achieve a good fit.

Step 1: Slip the U-00007 Nose Leg Fairing over the WD-1201 Nose Leg Assembly and clamp at the base as shown in Figure 1. It may be necessary to enlarge the hole in the U-00007 Nose Leg Fairing for the welds on the winch lug.

Trim the "tail" of the nose leg fairing as required to clear the tire as shown in Figure 1.

Step 2: Attach plumb lines to the upper portion of the U-00007 Nose Leg Fairing as shown in Figure 1 Section A-A. Align the nose leg fairing so that it is centered between the plumb lines.

Step 3: Clamp the upper portion of the U-00007 Nose Leg Fairing in place when satisfied with position. Drill #40 and cleco three places along the excess material as shown in Figure 1.

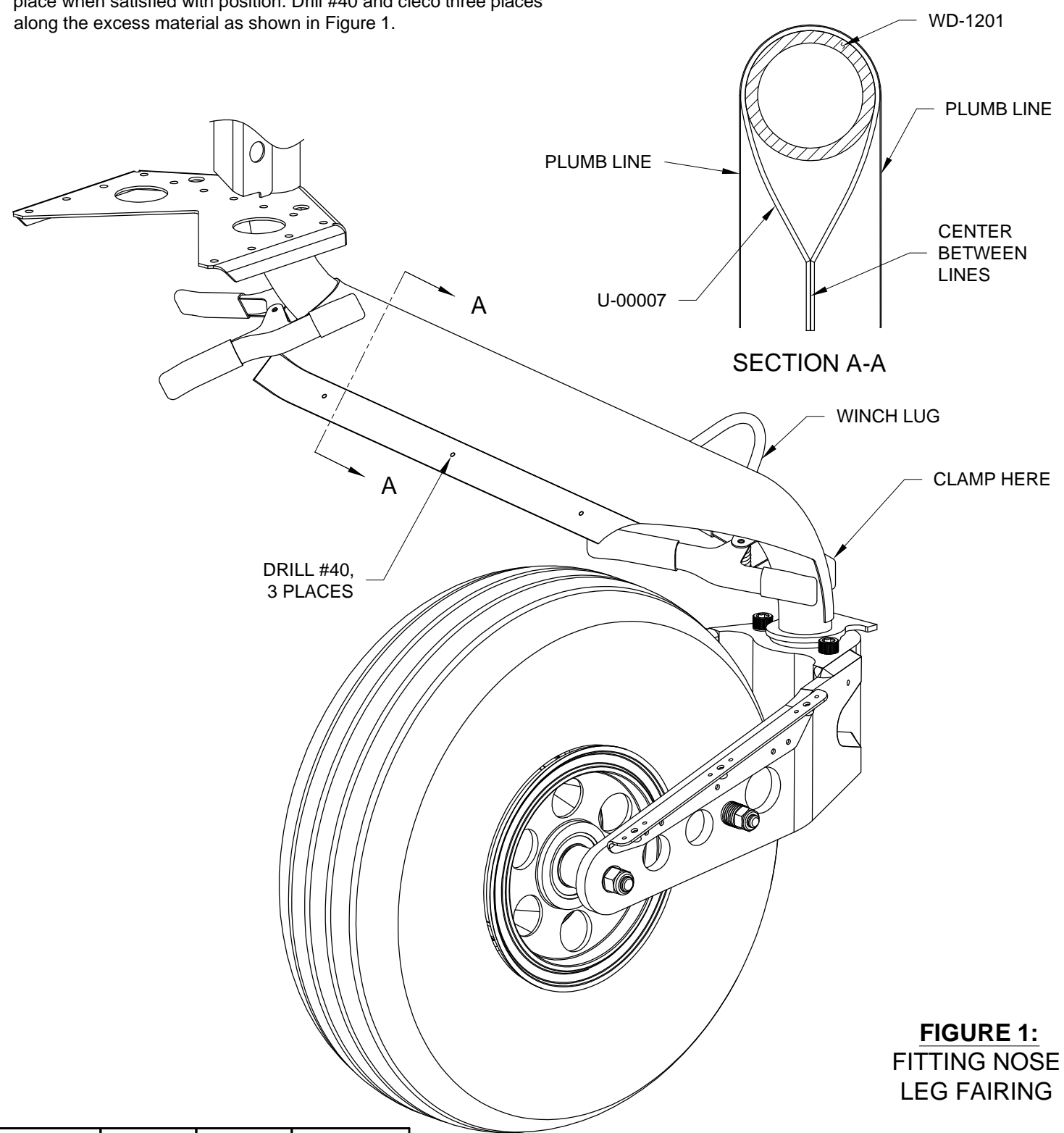

**FIGURE 1:
FITTING NOSE
LEG FAIRING**

Step 4: Lightly apply a length of masking tape to each side of the U-00007 Nose Leg Fairing as shown in Figure 2.

With the nose wheel turned to one side, take a square and align it against the nose leg fairing as shown in Figure 2. Rocking the square forward and aft over the taped area will produce a mark on the masking tape at the tangent of the nose leg fairing. Repeat on opposite side of the nose leg fairing.

Step 5: Measure 7 3/4 inches from the bottom of the loop on the WD-1201 Nose Leg Assembly and use a fine point felt pen to mark where the rub mark on the masking tape and length intersect on the sides of the U-00007 Nose Leg Fairing. See Figure 2.

Step 6: Drill #30 at the points marked on each side of the U-00007 Nose Leg Fairing into the WD-1201 Nose Leg Assembly.

Step 7: Remove the clamps, clecos, tape, and U-00007 Nose Leg Fairing from the WD-1201 Nose Leg Assembly.

Final-Drill #19 the two pilot holes in the nose leg fairing. Aggressively roughen the inner surface of the nose leg fairing around the #19 holes. Clean surface.

Step 8: Tap 8-32 the two holes drilled in the WD-1201 Nose Leg Assembly.

Step 9: Wrap tape around the gear leg, covering the area around the tapped holes.

Coat the threads of the screws called out in Figure 2 with wax.

Step 10: Slip the U-00007 Nose Leg Fairing onto the WD-1201 Nose Gear Assembly and clamp in place.

Mix a small amount of epoxy floc mixture to the consistency of peanut butter.

Squeeze enough of the mixture into the holes on either side of the nose leg fairing to make a disc 1/4 to 5/16 inch in diameter between the nose gear assembly and the nose leg fairing.

Insert the screws called out in Figure 2 in both sides of the nose leg fairing. Take care not to over tighten the screws.

Allow the epoxy floc mixture to cure, then remove the screws and nose leg fairing. Final-Drill the #19 holes in the nose leg fairing to clean out all debris. Remove the tape from the nose gear assembly.

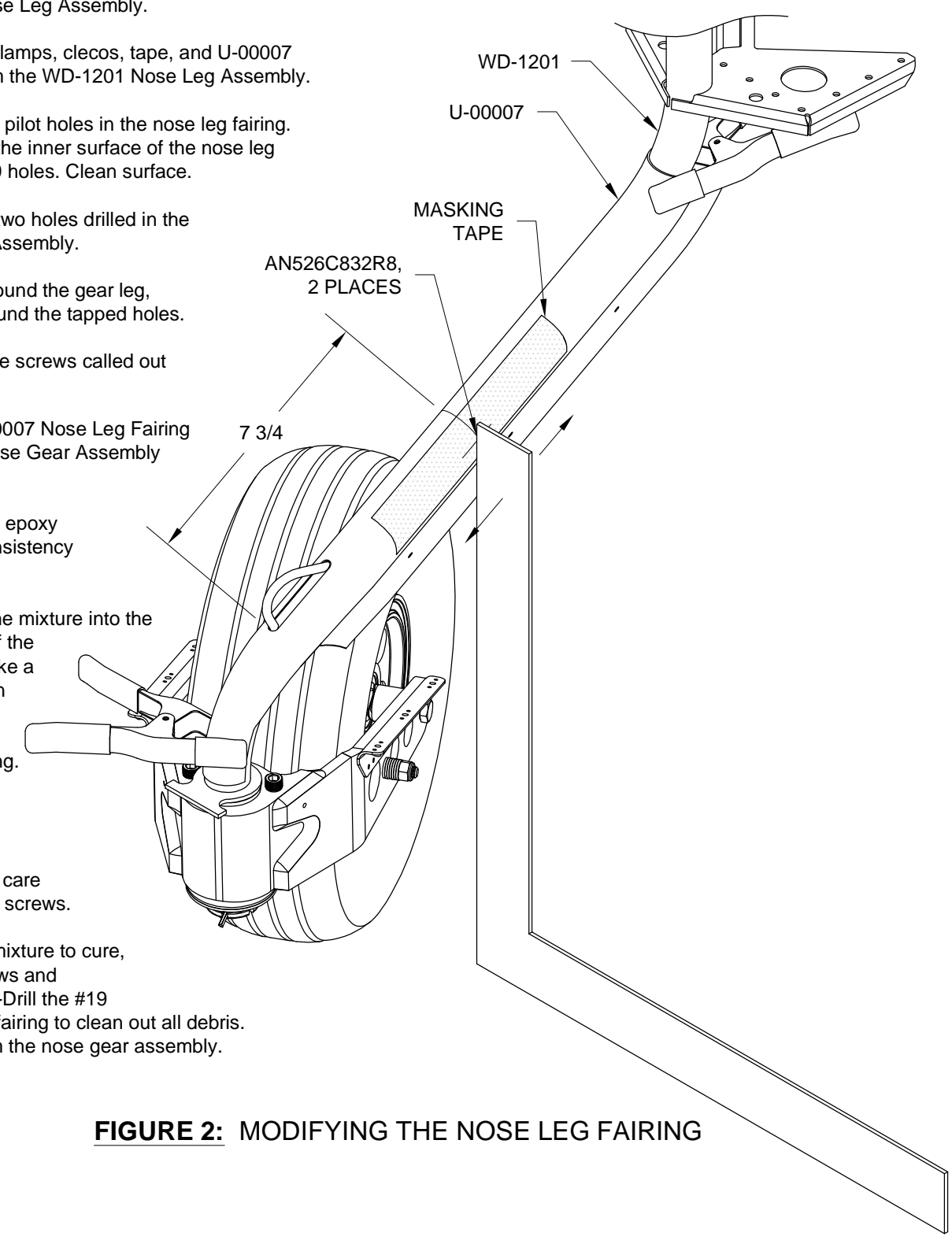
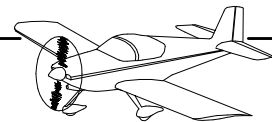

FIGURE 2: MODIFYING THE NOSE LEG FAIRING



Step 1: Make the U-00007B Nose Leg Hinge from Hinge, Piano .063. Draw a rivet centerline the full length of the outside of both halves of the nose leg hinge using the dimensions shown in Figure 1. Mark the rivet locations as shown in Figure 1.

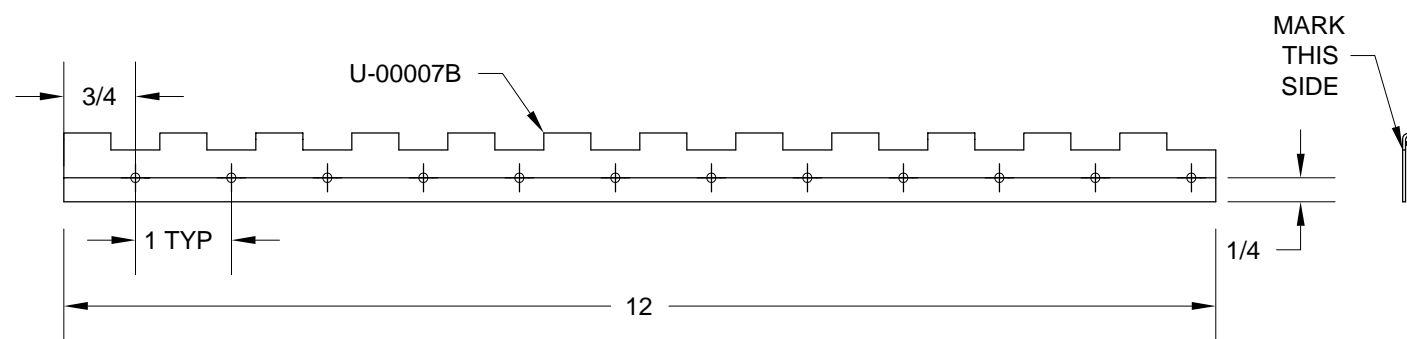

FIGURE 1: CUTTING HINGE HALVES

Step 2: Make the U-00007D Hinge Pin Retainer from a small piece of Hinge, Piano .063. Mark a center point and final-drill #27. Use a nutplate as called out in Figure 2 to match-drill #40 the rivet attachment locations.

Machine countersink the hinge pin retainer for the rivet heads, then attach the nutplate with the rivets called out in Figure 2.

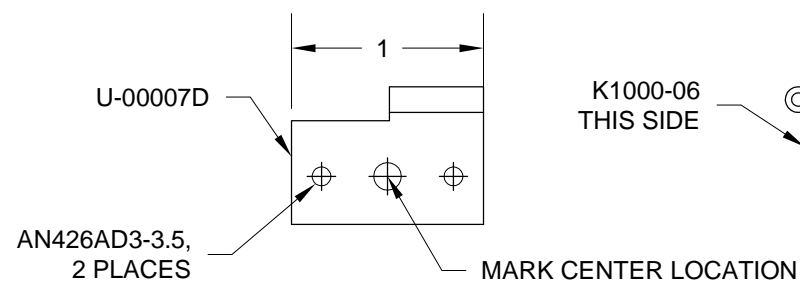

FIGURE 2: HINGE PIN RETAINER

Step 4: Machine countersink the rivet holes in both sides of the U-00007 Nose Leg Fairing. Remove the clecos, and U-00007B Nose Leg Hinge from the nose leg fairing. Final trim the nose leg fairing, removing the material as shown in Figure 4.

Rivet the nose leg hinges to the nose leg fairing with the rivets called out in Figure 4.

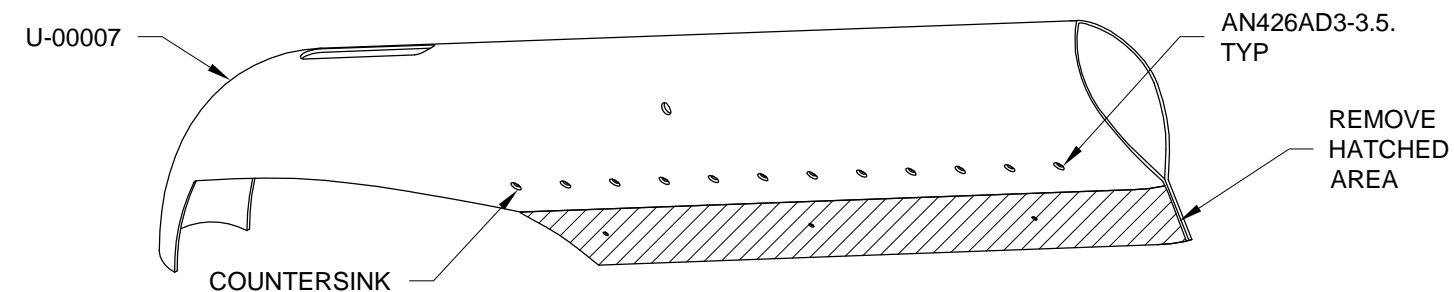

FIGURE 4: TRIMMING THE NOSE LEG FAIRING

Step 5: Fit the U-00007 Nose Leg Fairing to the WD-1201 Nose Gear Assembly as shown in Figure 5. Align the gear leg fairing by inserting the screws called out in 36-12 Figure 2. Install the U-00005A Nose Wheel Fairing Front and U-00005B Nose Wheel Fairing Aft. Rotate the nose wheel from side to side to check for clearance. Trim the nose leg fairing if it interferes with the nose wheel fairing. See Figure 5.

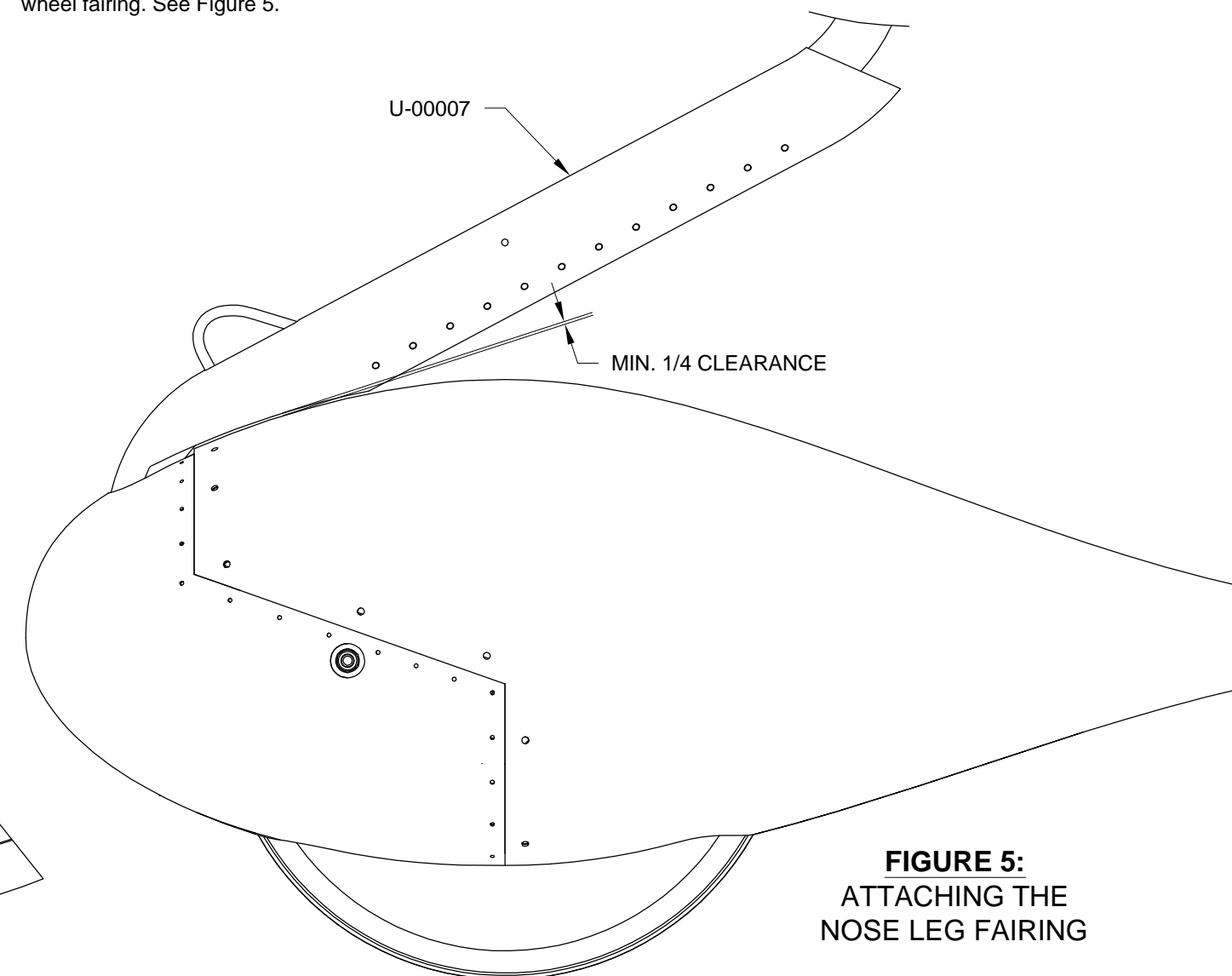
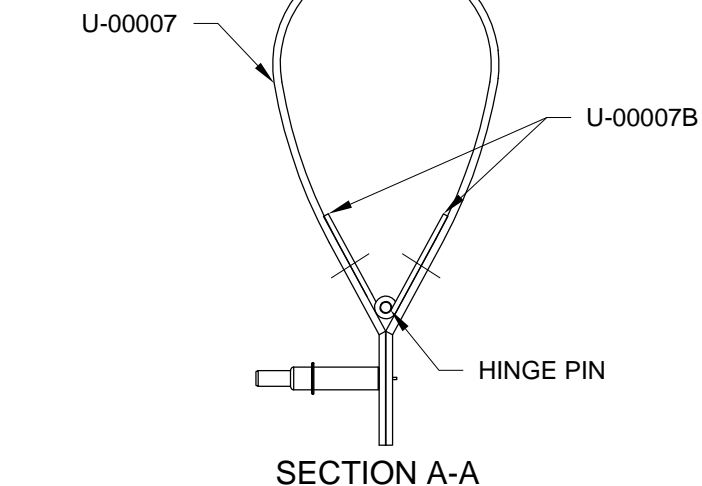

FIGURE 5: ATTACHING THE NOSE LEG FAIRING



Step 3: Install clecos in the U-00007 Nose Leg Fairing. Position the U-00007B Nose Leg Hinge inside the trailing edge of the fairing and clamp the ends of one hinge half in place as shown in Figure 3.

With the hinge ends clamped in position, begin at one end and drill #40 through the fairing and hinge using the fastener locations marked on the hinge to position the holes. Use light pressure and high drill speed allowing the bit to cut through without distorting the hinge. Work from one end of the fairing to the other, clecoing each hole before drilling the next.

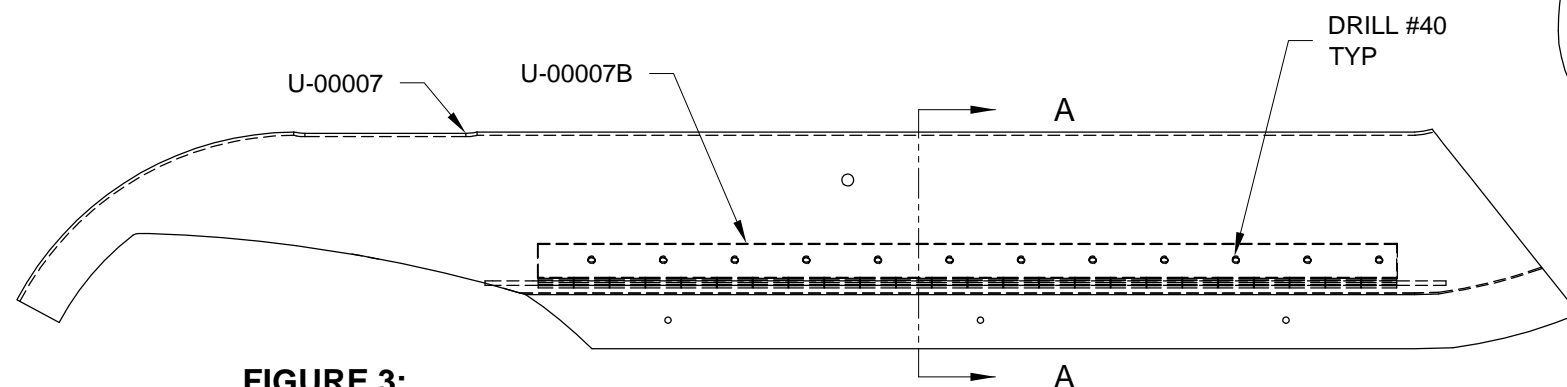
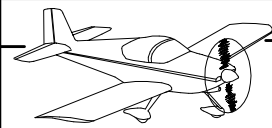

FIGURE 3: POSITIONING HINGE IN FAIRING



Step 1: Bend one end of the provided hinge pin to create U-00007C Hinge Pin. The pin should fit into the loop of the U-00007D Hinge Pin Retainer as shown in Figure 1. Dimensions given in Figure 2 are for reference only, adjust as required to achieve a good fit.

Step 2: With the U-00007D Hinge Pin Retainer attached to one end of the U-00007C Hinge Pin, slide the hinge pin retainer inside of the U-00007 Nose Leg Fairing and press against the side. Mark the center of the nutplate on outside of the nose leg fairing with a fine point felt pen.

Final-Drill the nose leg fairing #27 for the screw called out in Figure 1. Install screw through nose leg fairing and into hinge pin retainer and check the length of hinge protruding from the other end of the nose leg fairing hinge. Trim pin as required.

Step 3: Remove the U-00007 Nose Leg Fairing and apply wax to an approximately 1 inch diameter area of the WD-1201 Nose Gear Assembly as shown in Figure 1. Roughen the inside of the nose leg fairing in the same area. Apply a bead of RTV approximately 1/8 inch thick and 1/2 inch in diameter to the nose leg fairing. Install the nose leg fairing on the nose gear assembly. Allow to cure.

Installation Complete.

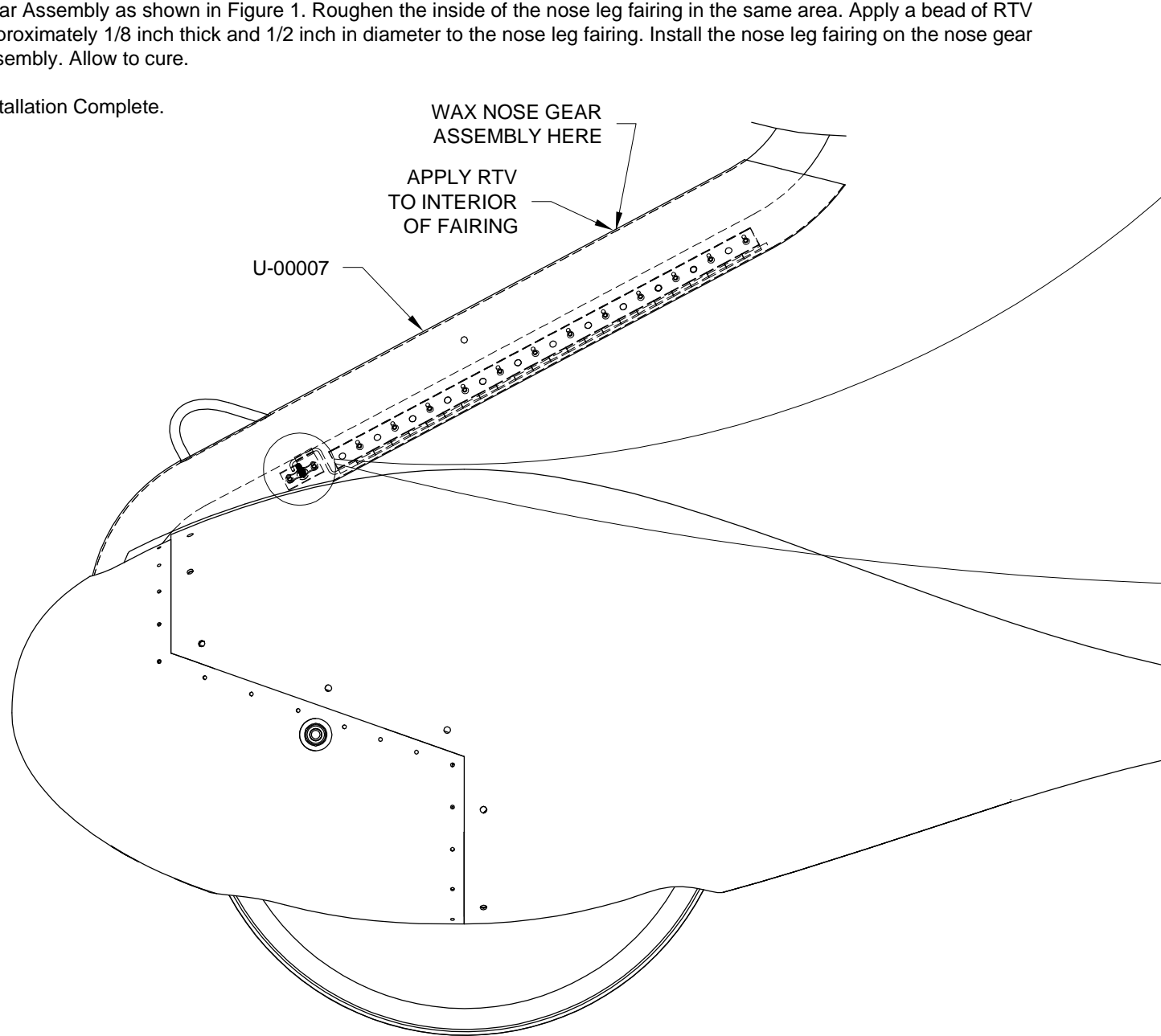

FIGURE 1: HINGE PIN RETAINER LOCATION

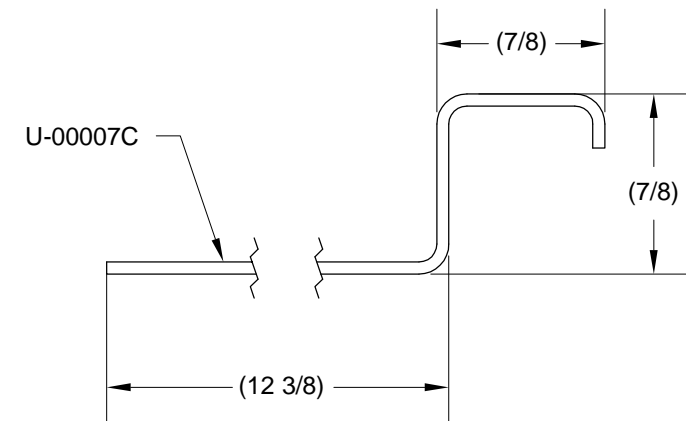
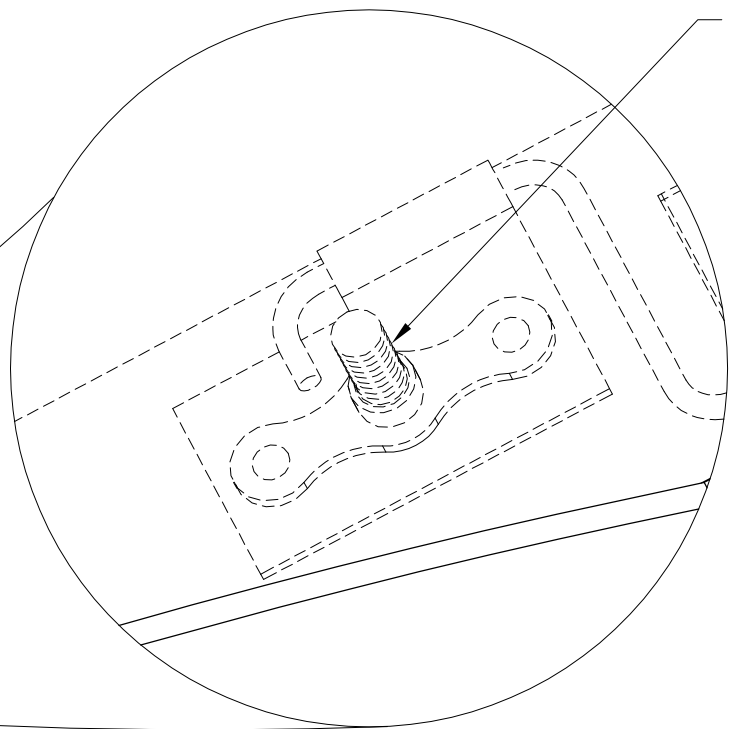
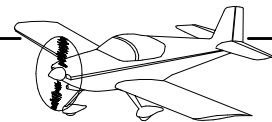

FIGURE 2: BENDING HINGE PIN



NOTE: Any weight and balance information recorded for the aircraft must be updated. Depending on the state of your kit some steps may not be applicable.

Step 1: In the RV-12 Maintenance Manual (MM) "INSTALLED EQUIPMENT LIST" table, add "GEAR LEG & WHEEL FAIRINGS" to the "ITEM" column. On the same line add a checkmark to the "INSTALLED" column.

Enter 9.3 lb for "Weight", 78.925 in for "Location/Arm" and 734 in-lb "Moment" onto the same line as "GEAR LEG & WHEEL FAIRINGS".

In the RV-12 Pilot Operating Handbook (POH) "OPTIONAL EQUIPMENT LIST" table, add "GEAR LEG & WHEEL FAIRINGS" to the "ITEM" column. On the same line add a checkmark to the "INSTALLED" column.

Enter 9.3 lb for "Weight", 78.925 in for "Location/Arm" and 734 in-lb "Moment" onto the same line as "GEAR LEG & WHEEL FAIRINGS".

NOTE: Steps 2-4 on this page are only applicable if a final weight and balance as specified in the PAP has been completed.

Step 2: In the RV-12 Pilot Operating Handbook (POH) "YOUR AIRPLANE" table, enter the new total values for the arm, weight, and moment of the installed equipment.

Step 3: In the RV-12 POH "YOUR AIRPLANE" table, recalculate and enter new values for the Empty Weight, Empty Moment, and Empty Arm.

Step 4: Make an entry, as calculated in the previous step, on the WEIGHT AND BALANCE RECORD page of the RV-12 Maintenance Manual as follows:

As of this date: ___/___/___ the following values represent current Weight and Balance calculations resulting from the installation of the Gear Leg and Wheel Fairings Optional Kit.

Revised Empty Weight: _____ lbs

Revised Empty Moment: _____ in-lbs

Revised Empty Arm: _____ in

Signed: _____

NOTE: The remaining steps on this page are only applicable for aircraft which have passed a final airworthiness inspection.

Step 5 (ELSA): Make an appropriate entry in the airframe logbook. See example below:

Installed the GEAR LEG & WHEEL FAIRINGS option in accordance with Van's Aircraft KAI Section 36 and confirmed proper operation.

Signature _____ Certificate # _____

Step 5 (SLSA): Complete the notification N 14-08-07 (available from the Van's Aircraft web site) corresponding to the GEAR LEG & WHEEL FAIRINGS installation.

Step 6: Section complete.



THIS PAGE INTENTIONALLY LEFT BLANK