

SECTION 40: LIGHTING

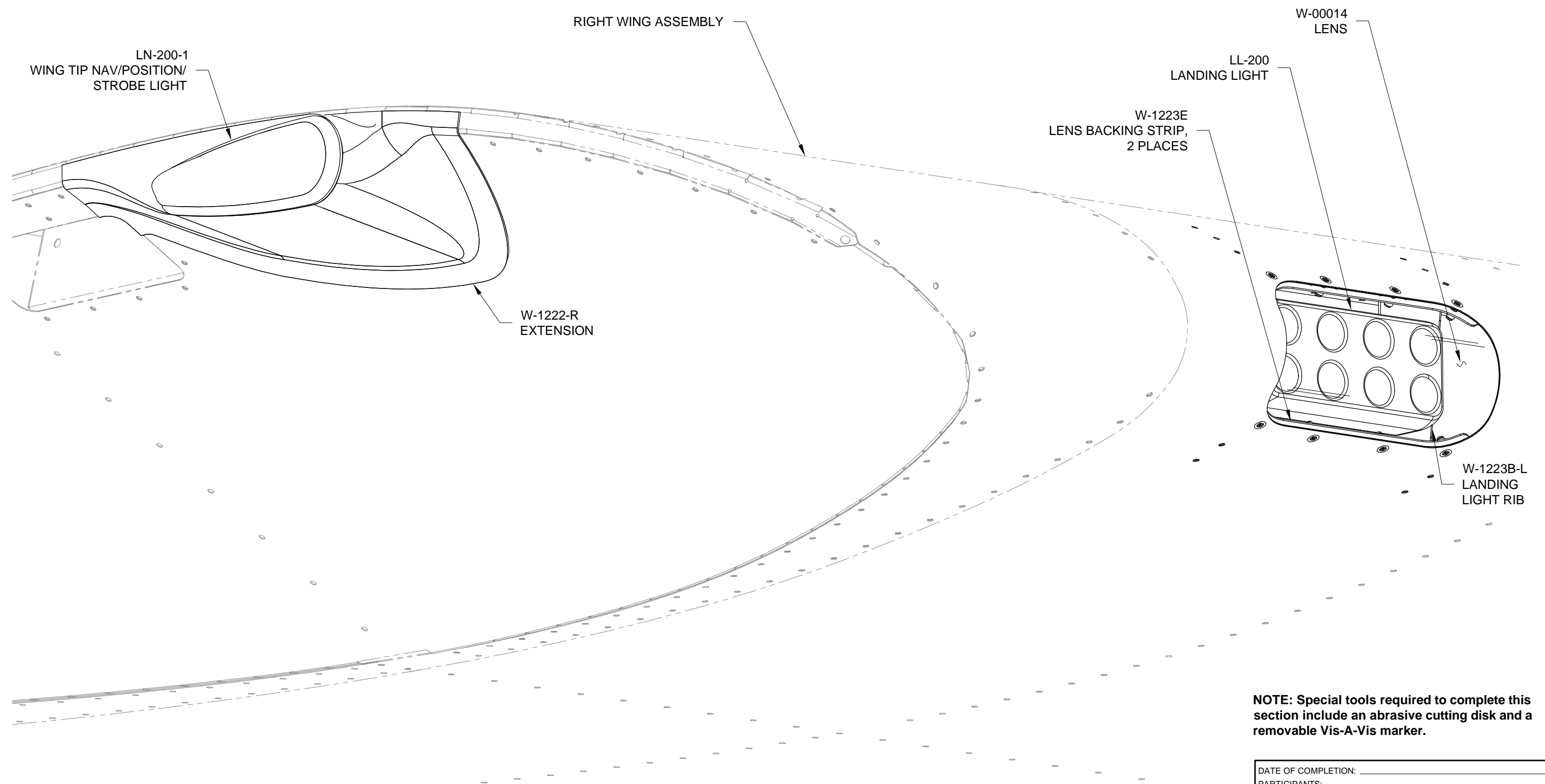

NOTE: Special tools required to complete this section include an abrasive cutting disk and a removable Vis-A-Vis marker.

DATE OF COMPLETION: _____
PARTICIPANTS: _____
DATE: 11/09/16 REVISION: 2 RV-12 PAGE 40-01



NOTE: Do not use the template called out on this page to mark all the holes at once! Mark the top holes with the template aligned to the top rivets and the bottom holes with the template aligned with the bottom rivets.

Step 1: Align the lines on the top half of the template supplied on Page 40-17 with the corresponding top leading edge rib rivets.

Use a tool with a sharp point to mark the center of all six rivet holes and the four screw holes that will be added to the top of the W-1203-R Outbd Wing Skin.

Mark the perimeter of the upper half of the landing light cutout.

Align the bottom half of the template with the corresponding bottom leading edge rivets, then mark the four bottom rivet holes, the four bottom screw holes and the bottom half of the landing light cutout.

Step 2: Drill #40 the rivet and screw holes marked in Step 1 into the W-1203-R Outbd Wing Skin.

Final-Drill the rivet and screw holes to #30. See Figure 1.

Step 3: Remove the material inside the landing light cutout.

Deburr the edge of the landing light cutout and the rivet holes drilled in Step 2.

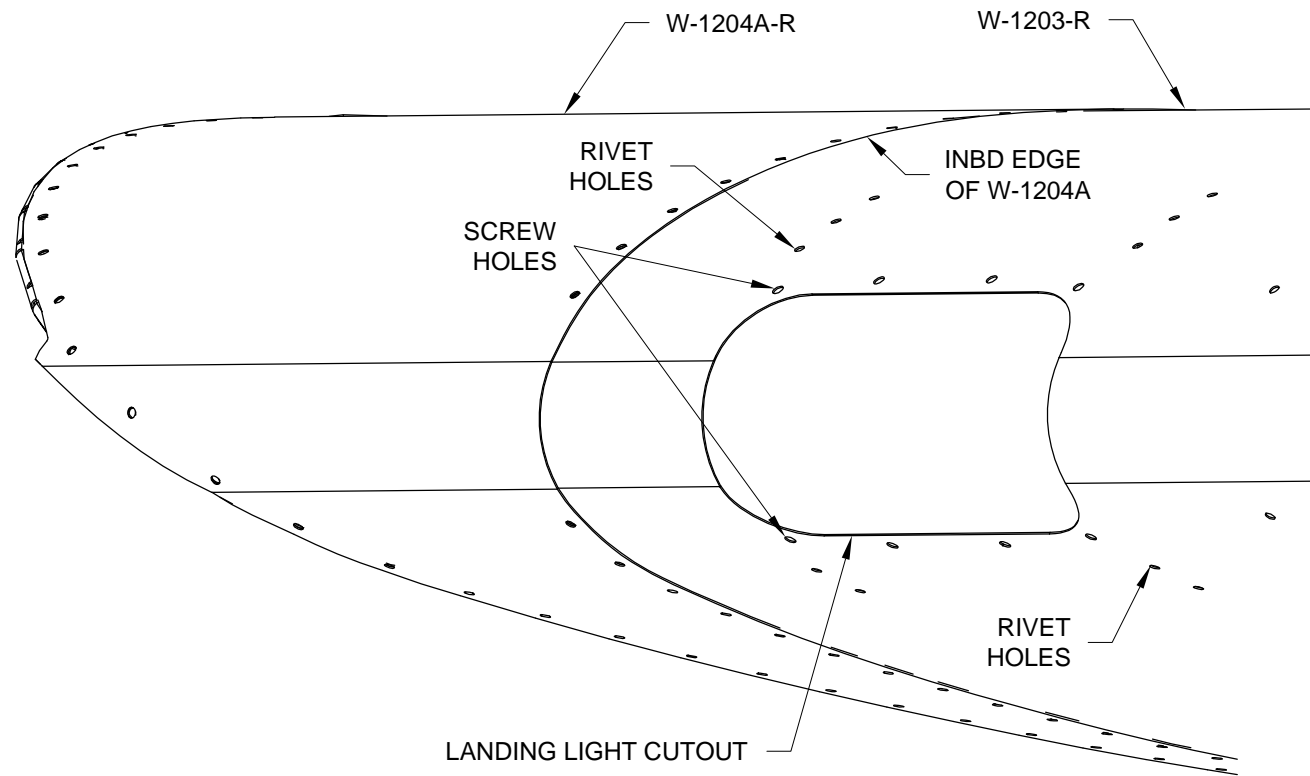

FIGURE 1: MAKING THE LANDING LIGHT CUTOUT

Step 4: Remove the three rivets indicated in Figure 2 from each W-1204D Wing Tip Close-Out.

Step 5: Layout and then remove the shaded area from the W-1204D Wing Tip Close-Out using the template on Page 40-19. This will create a wing tip access opening to reach into the wing tip and route wires. See Figure 2.

Step 6: Drill #19 a hole near the forward edge of the access opening in the W-1204D Wing Tip Close-Out as shown in Figure 2.

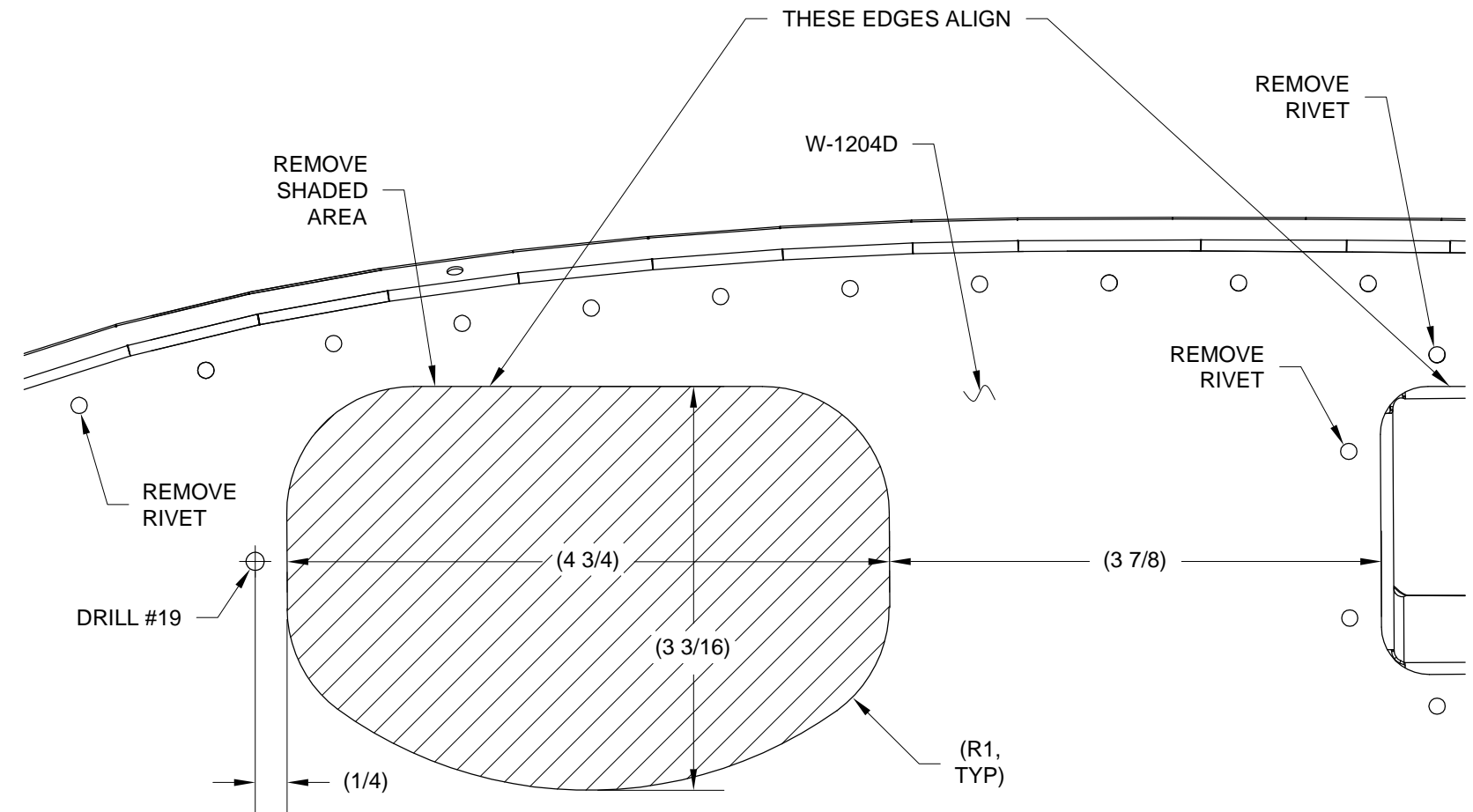
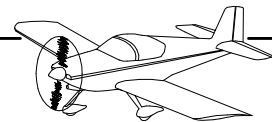

FIGURE 2: MAKING THE WING TIP ACCESS OPENING



Step 1: Wrap masking tape around each end of the W-00014 Lens then insert the lens into the opening in the W-1203-R Outbd Wing Skin. See Figure 1.

Step 2: Use the tape to hold the W-00014 Lens tight against the W-1203-R Outbd Wing Skin.

Match-Drill #30 using a plexi bit and cleco the eight holes in the outbd wing skin surrounding the landing light cutout into the lens. See Figure 1.

Step 3: Mark the inbd and outbd edges of the landing light cutout in the W-1203-R Outbd Wing Skin onto the W-00014 Lens with a removable Vis-A-Vis marker or equivalent. See Figure 1.

Step 4: Remove the W-00014 Lens and the tape.

Final-Drill #27 using a plexi bit the holes in the lens.

Step 5: Trim the W-00014 Lens using the dimensions in Figure 1 and the reference marks made in Step 3.

Start by trimming within 1/32 inch of the final shape with an abrasive cutting disk then finish by sanding.

Step 6: Final-Drill #27, deburr, then dimple the eight holes in the W-1203-R Outbd Wing Skin surrounding the landing light cutout for the head of a #6 screw.

Step 7: Machine countersink the screw holes in the W-00014 Lens for the corresponding dimples in the W-1203-R Outbd Wing Skin.

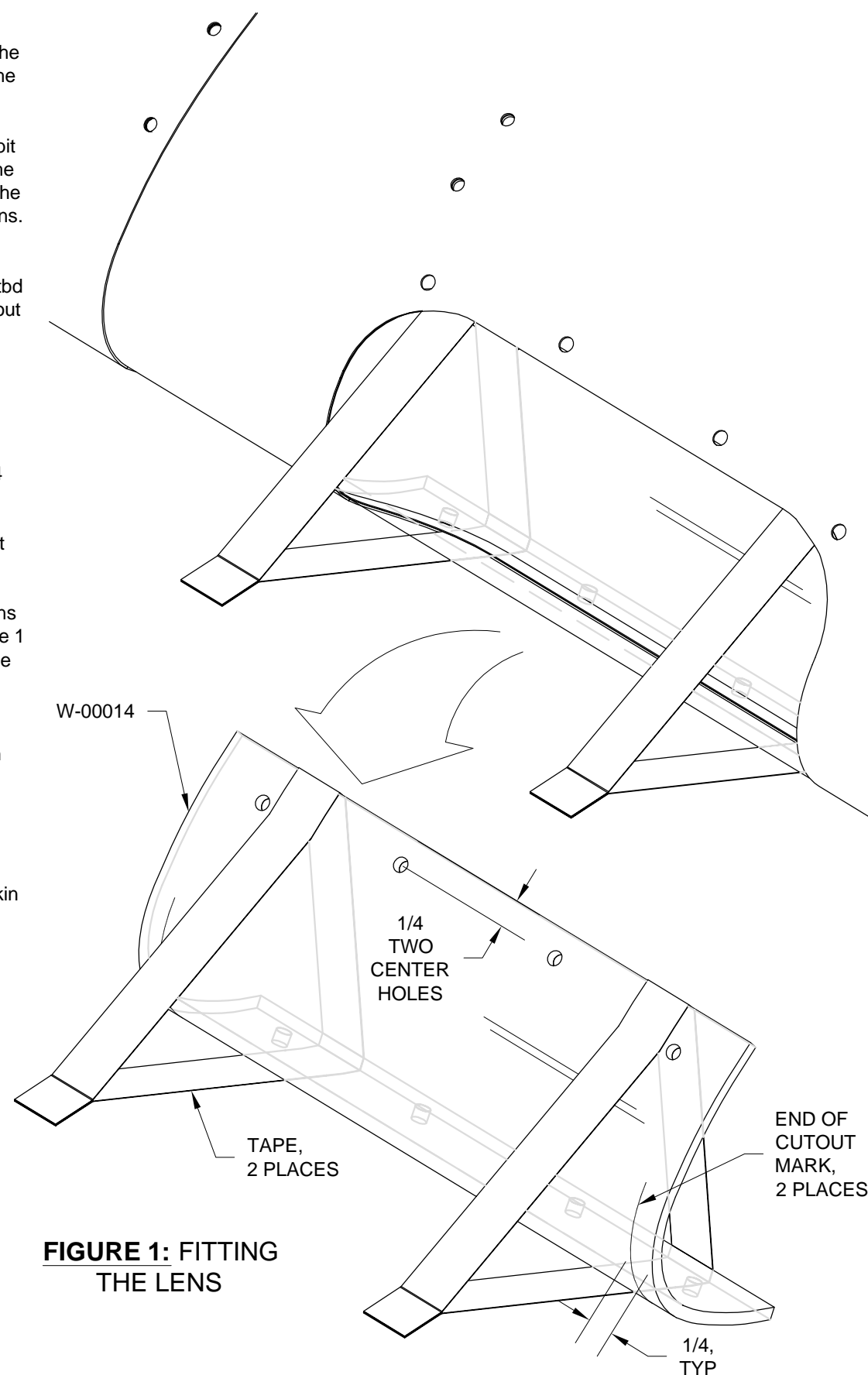

FIGURE 1: FITTING THE LENS

Step 8: Dimple the nutplates and both W-1223E Lens Backing Strips at all nutplate attach locations.

Rivet nutplates to both lens backing strips as shown in Figure 2.

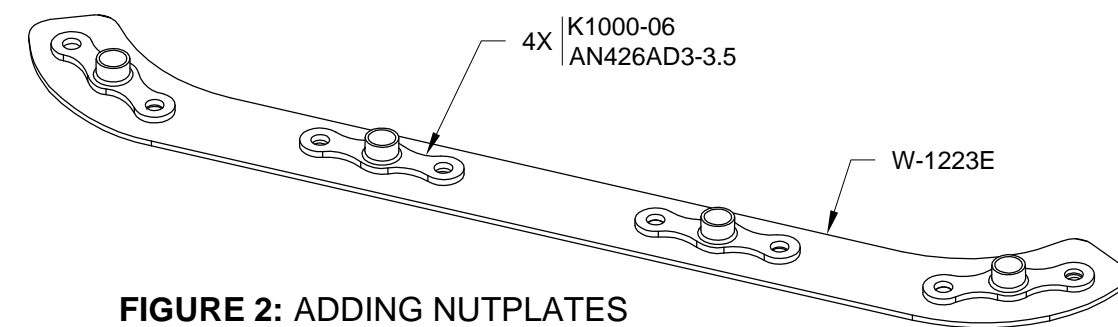

FIGURE 2: ADDING NUTPLATES TO THE LENS BACKING STRIPS

Step 9: Temporarily position the W-1223E Lens Backing Strips on the W-00014 Lens as shown in Figure 3.

Use the edge of the lens backing strips to mark the lens for trimming.

Step 10: Trim back the corners of the W-00014 Lens to match the edges of the W-1223E Lens Backing Strips as shown in Figure 3.

Step 11: Radius the edges of the W-00014 Lenses. Smooth all trim marks with 220 grit sandpaper.

Deburr the interior sides of the screw holes.

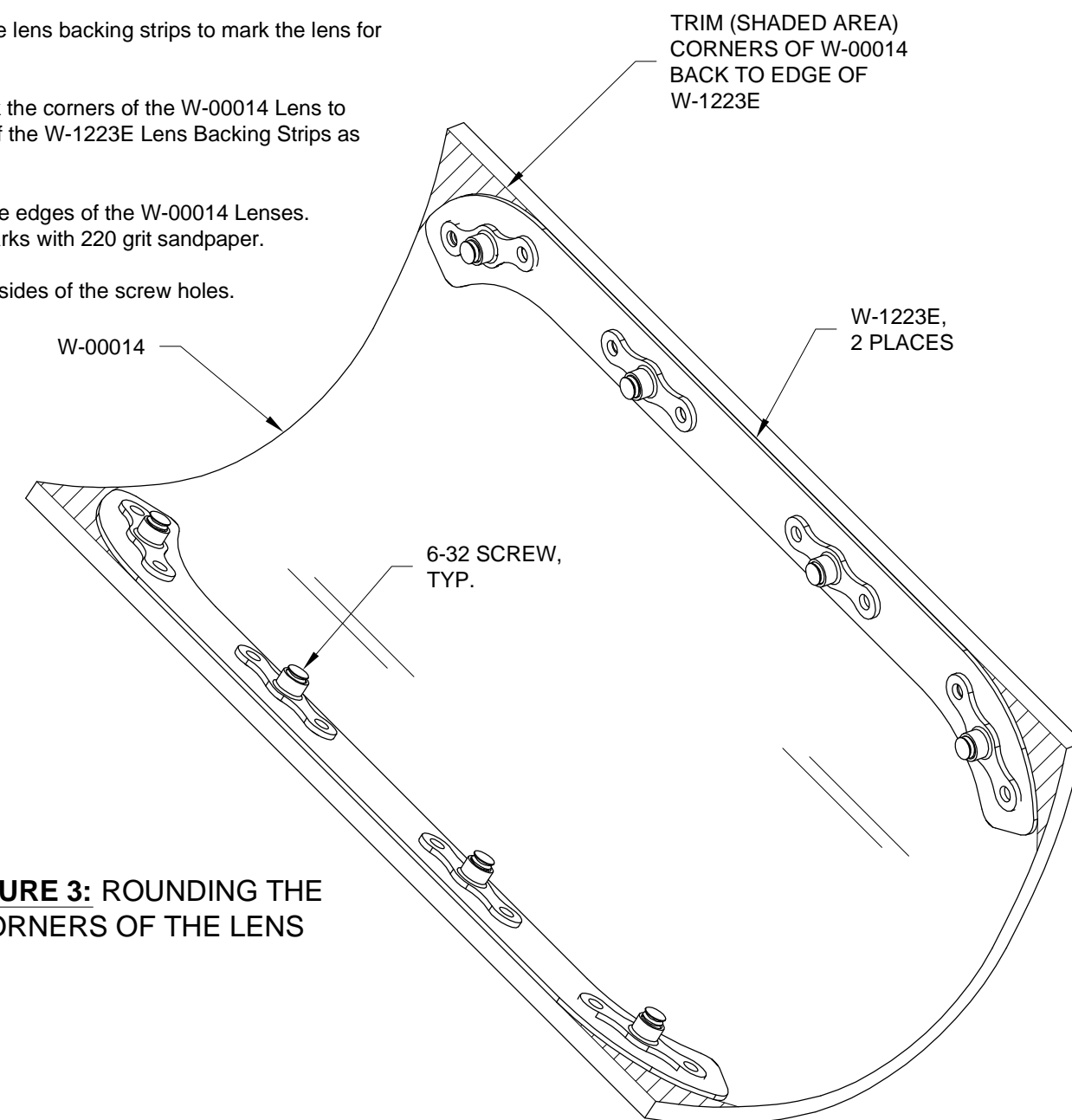

FIGURE 3: ROUNDING THE CORNERS OF THE LENS



Step 1: Use a step drill to final-drill the two tooling holes in the W-1223B Landing Light Rib to Ø3/8. See Figure 1.

Step 2: Remove the shaded area on the W-1223B Landing Light Rib to separate the part into the W-1223B-L & -R Landing Light Ribs.

Step 3: Deburr the slots and edges of both the W-1223B-L & -R Landing Light Ribs.

Flute the rib flanges between the holes if necessary, so that the flange rivet holes align with the holes drilled in the wing skin.

Check that an AN3 bolt will easily slide in the slot.

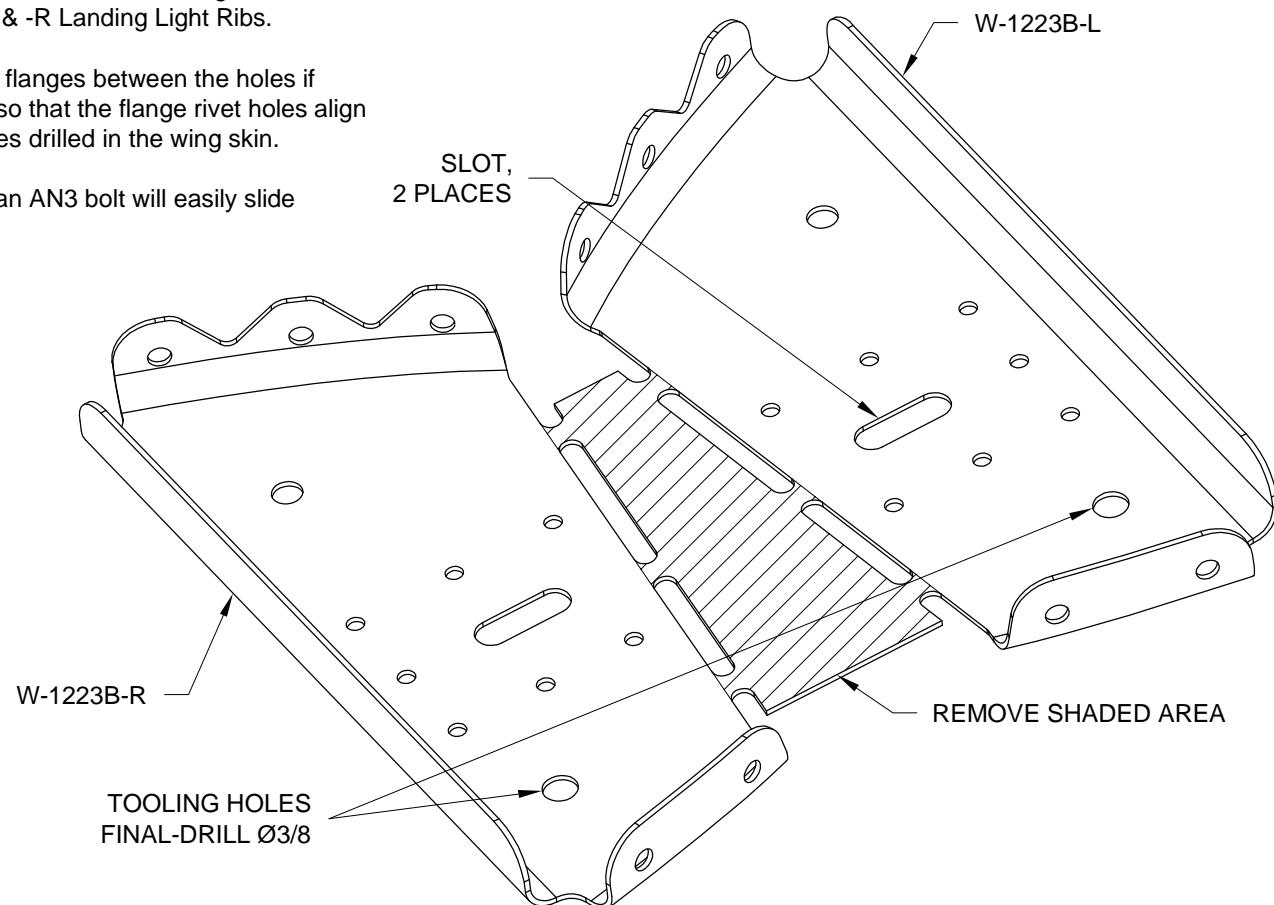

FIGURE 1: BREAKING APART THE LANDING LIGHT RIBS

Step 4: Machine countersink both W-1223C Rib Doublers for the rivets called out in Figure 2.

Step 5: Deburr the slot in both W-1223C Rib Doublers.

Check that an AN3 bolt will easily slide in the slot.

Step 6: Rivet the W-1223C Rib Doubler to the W-1223B-L Landing Light Rib as shown in Figure 2. Repeat this step for the remaining rib doubler and W-1223B-R Landing Light Rib.

Step 7: Add a snap bushing to the W-1223B-L & -R Landing Light Ribs. Orient the snap bushing as shown in Figure 2!

NOTE: When making wires, label them (mark all long wires at both ends).

NOTE: Several places in this section require crimping Molex style pins. Use a proper crimping tool! Ensure that the male pins are snapped into the female housing and female pins are snapped into the male housing. The Molex connector housings and pins are supplied with the LN-200-1 Wing Tip Nav/Position/Strobe Lights and the LL-200 Landing Light.

Step 8: Fabricate a WH-B215 (WHT) Landing Light Ground Wire by cutting a piece of 18 gauge wire 8 inches long.

Strip the ends of the wire and crimp on a female Molex pin on one end.

Snap the pin into a male Molex connector housing. Pin location is not critical.

Crimp a ring terminal to the other end of the landing light ground wire. See Figure 2.

Step 9: Attach the WH-B215 (WHT) Landing Light Ground Wire to the W-1223B-L Landing Light Rib using the hardware called out in Figure 2.

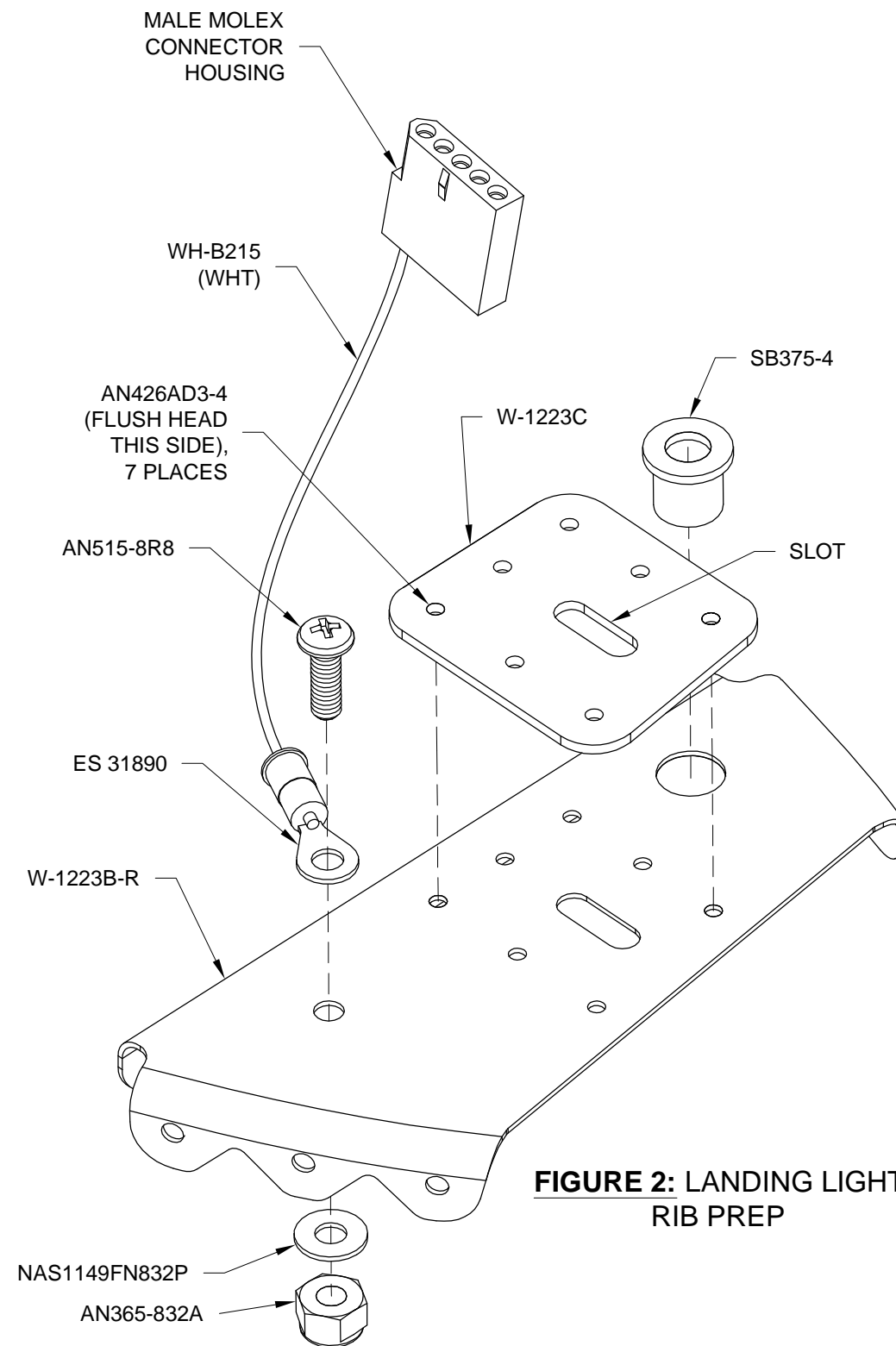

FIGURE 2: LANDING LIGHT RIB PREP



Step 1: Remove the two screws from the ES-00077 Floating 8 Pos Connector Female & ES-00078 Floating 8 Pos Connector Male and let hang down from the nose rib. See Figure 1.

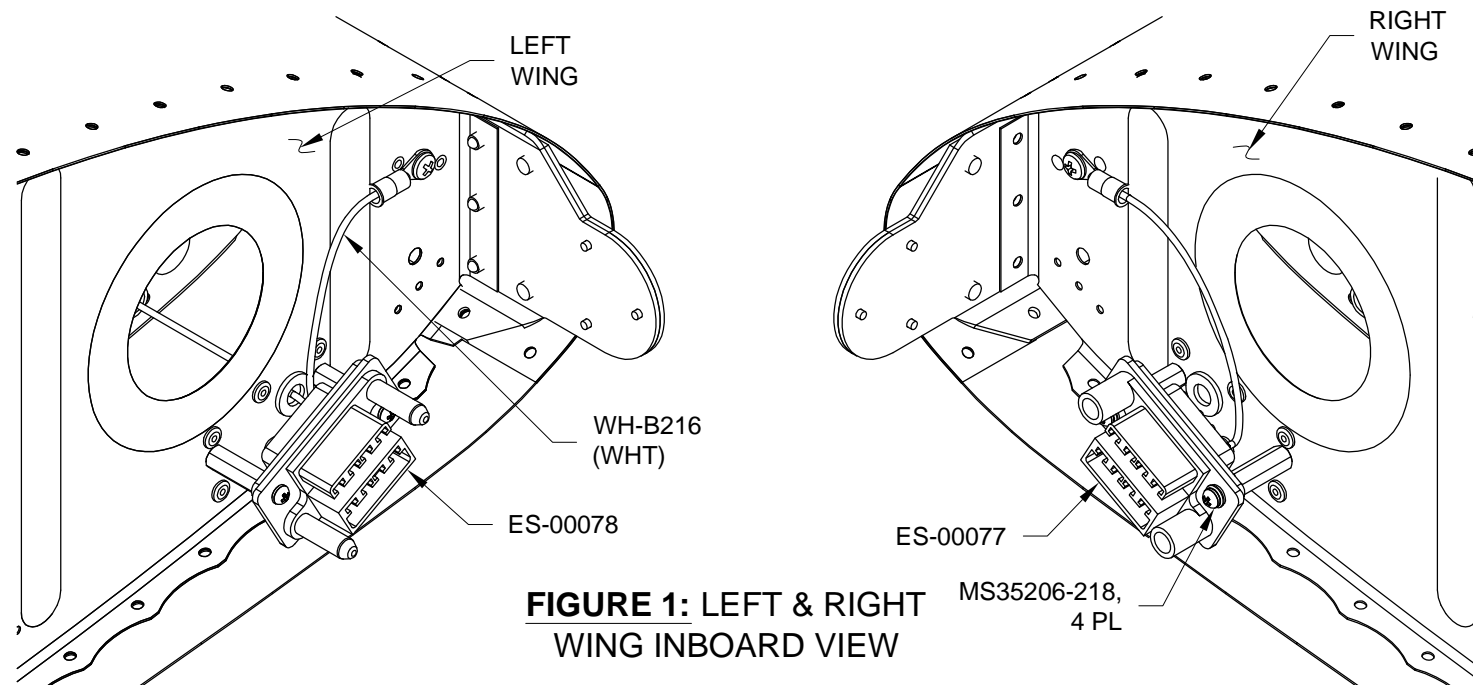

FIGURE 1: LEFT & RIGHT WING INBOARD VIEW

NOTE: Label wires on both ends of the wire with a piece of tape and a marker.

Step 2: Fabricate two WH-B212 (WHT) Nav Power Wires by cutting two pieces of 18 gauge wire 153 inches long.

Step 3: Fabricate a WH-B213 (WHT) Pulse Power Wire and WH-B214 (WHT) Landing Light Power Wire by cutting two pieces of 18 gauge wire 130 inches long.

Step 4: Fabricate two WH-B203 (WHT) Strobe Power Wires by cutting two pieces of 18 gauge wire 153 inches long.

Step 5: Fabricate two WH-B318 (WHT) Strobe Synch Wires by cutting two pieces of 18 gauge wire 153 inches long.

NOTE: See chapter 5W Open Barrel Crimp. For a good example of an open barrel crimp see the WH-P274 (WHT) Lighting Power update Wire provided with the Lighting kit.

NOTE: Wires shown in gray line weight in Figures 2 & 3 are for reference and are already installed in Section 16.

Step 6: Strip one end of all the fabricated wires in Steps 2 thru 5 and crimp on an ES-00079 Floating Connector Pin 16-20 AWG as shown in Figures 2 & 3.

Step 7: Attach the crimped wires called out in Figure 2 to the ES-00078 Floating 8 Pos Connector Male. On the back of the connector is a number for the wire position. See also Page 40-06, Figure 1.

Step 8: Attach the crimped wires called out in Figure 3 to the ES-00077 Floating 8 Pos Connector Female. See also Page 40-06, Figure 2.

Step 9: On the left wing use the string installed in Section 16 to pull the WH-B212 (WHT) Nav Power Wire, WH-B203 Strobe Power Wire, WH-B318 Strobe Synch Wire, and another string from the wing root into the wing tip.

Step 10: On the right wing use the string installed in Section 16 to pull the WH-B212 (WHT) Nav Power Wire, WH-B213 (WHT) Pulse Power Wire, WH-B203 (WHT) Strobe Power Wire, WH-B318 (WHT) Strobe Synch Wire, WH-B214 (WHT) Landing Light Power Wire, and another string from wing root into the most outboard rib bay.

Step 11: Reinstall the screws and connectors that were removed in Step 1.

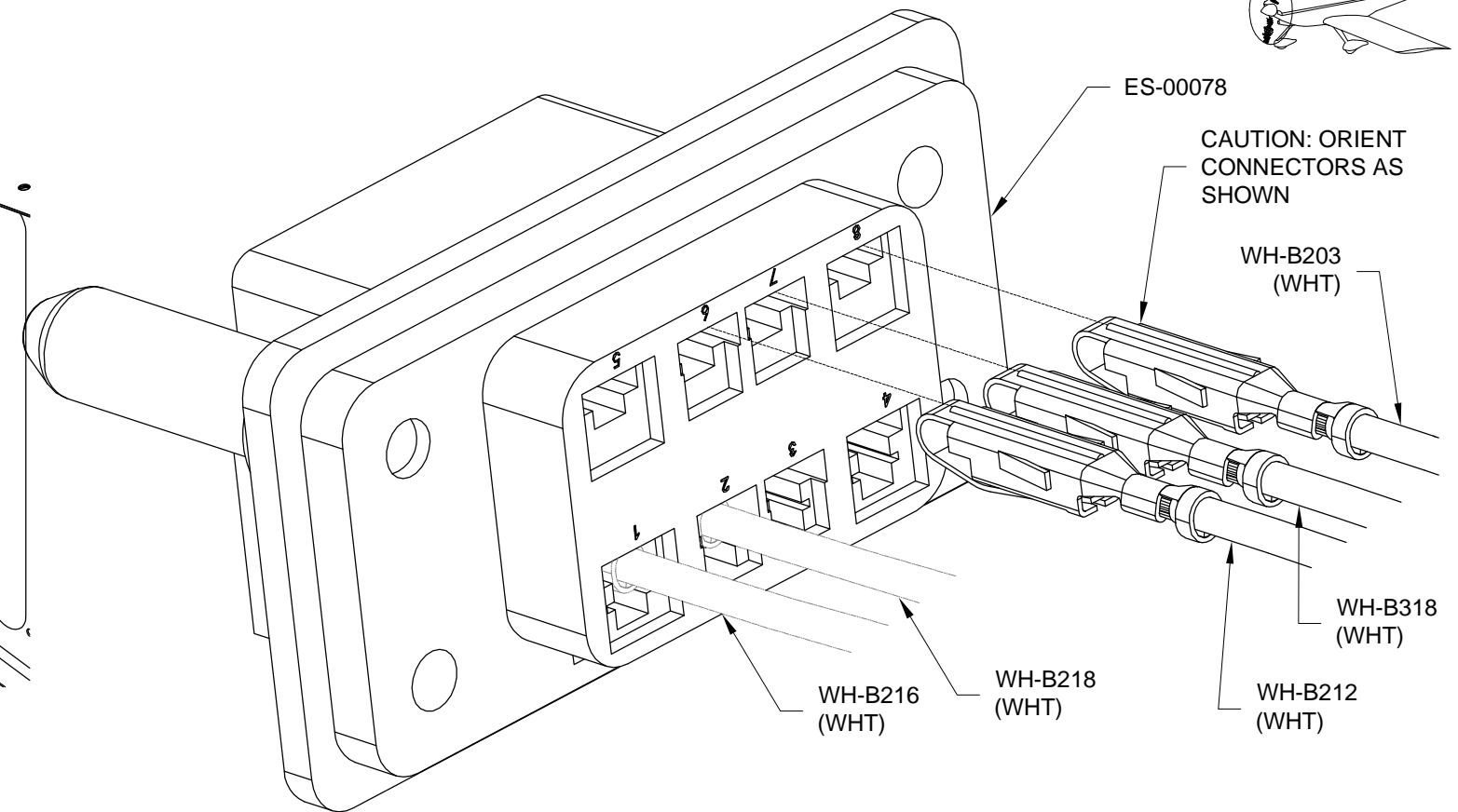

FIGURE 2: LEFT WING CONNECTION VIEW

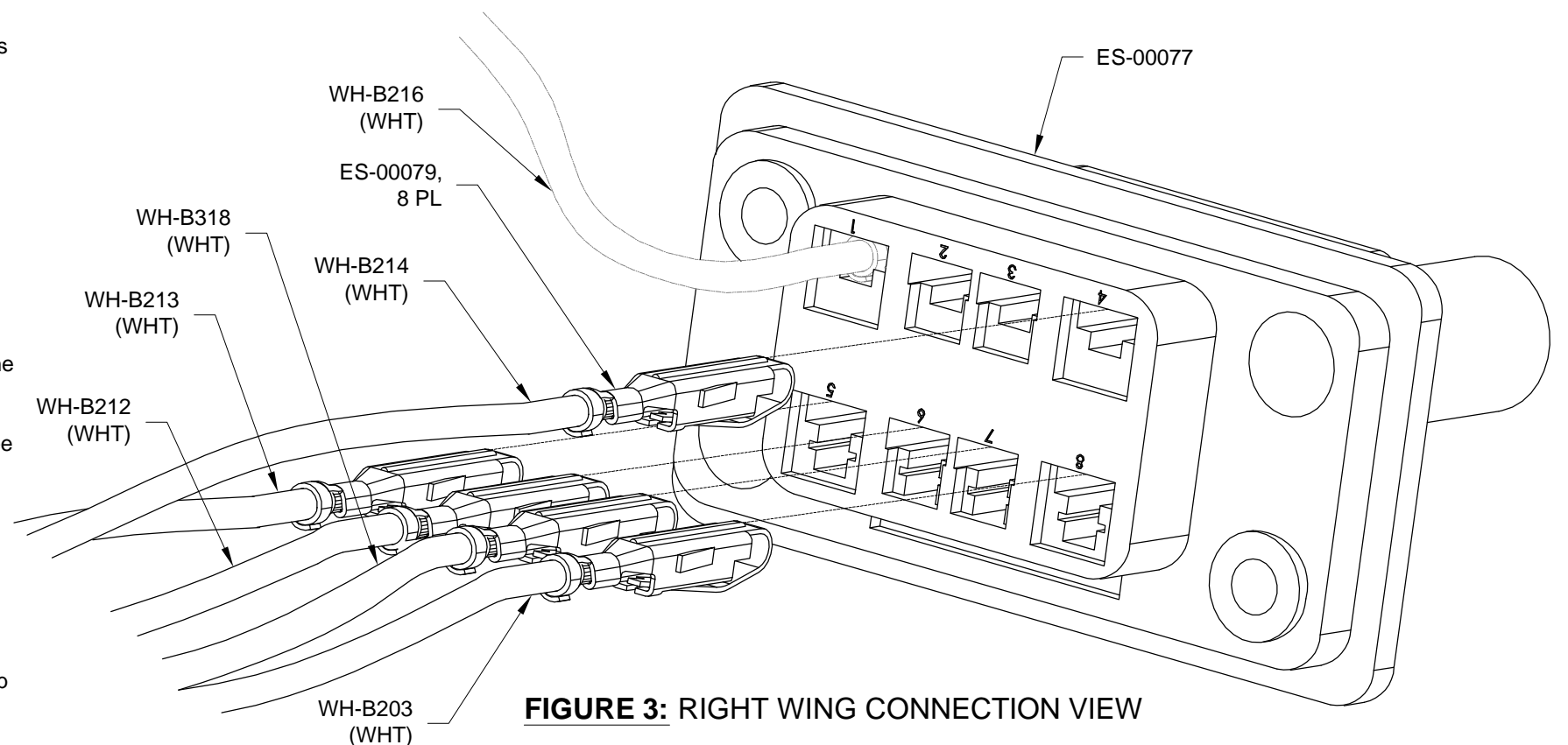

FIGURE 3: RIGHT WING CONNECTION VIEW

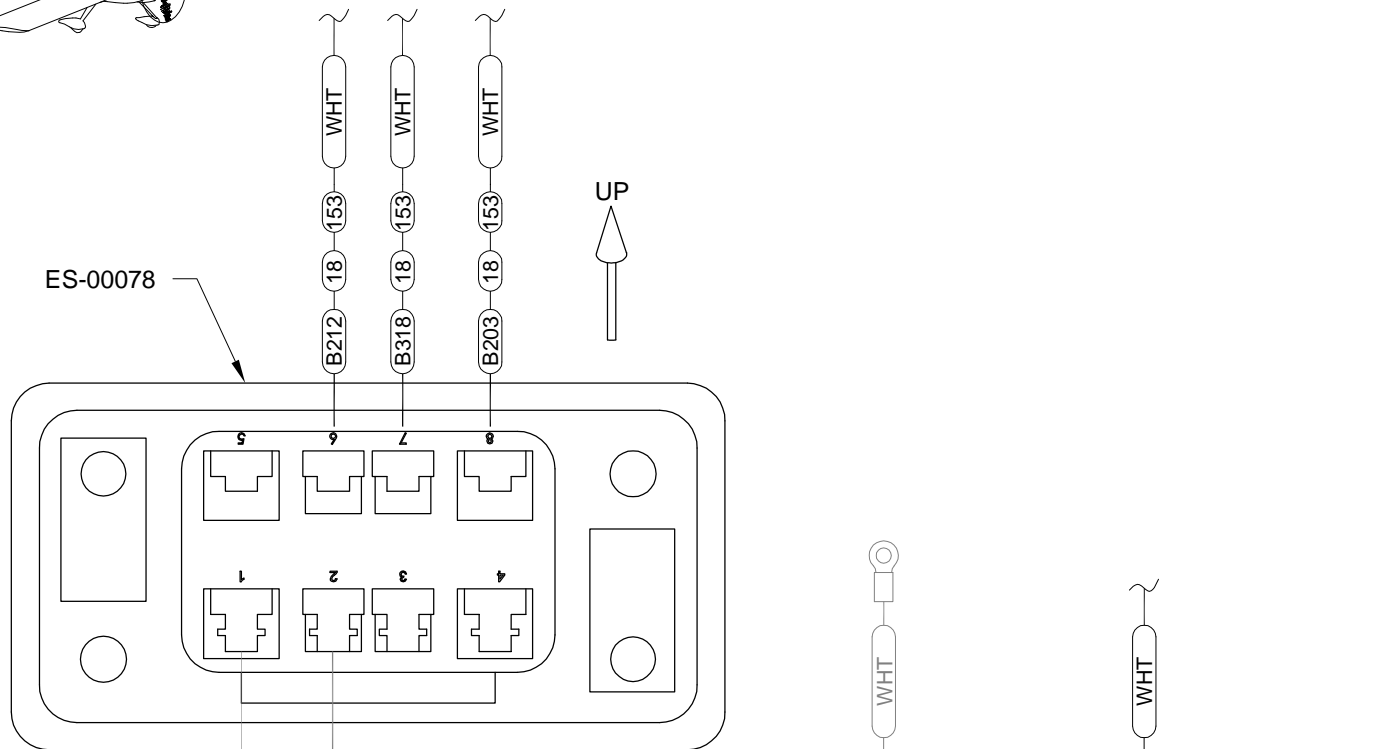

FIGURE 1: LEFT WING CONNECTOR MALE BACK VIEW

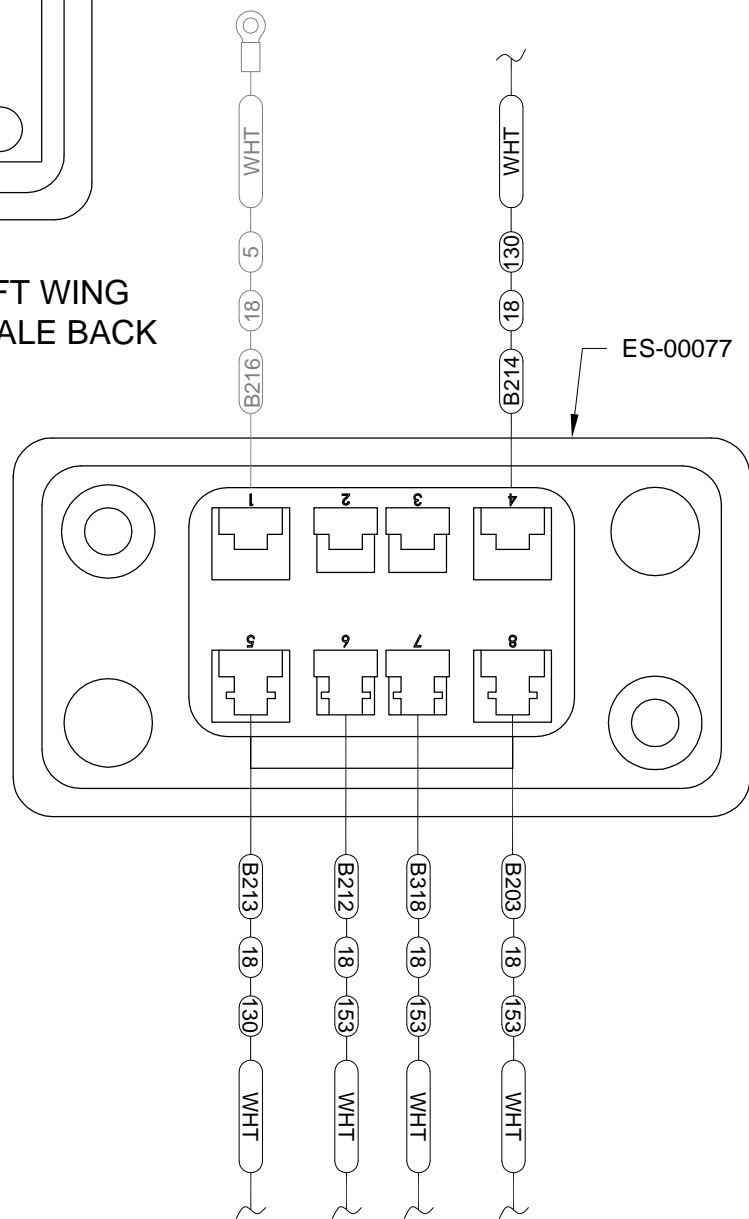

FIGURE 2: RIGHT WING CONNECTOR FEMALE BACK VIEW

NOTE: If your hand size is large it may be easier to pre install the LL-200 landing light to the W-1223B-L & -R Landing Light Ribs. See Page 40-07.

Step 1: Rivet the W-1223B-L & -R Landing Light Ribs to the W-1203-R Outbd Wing Skin as shown in Figure 3.

Step 2: Insert a snap bushing into the W-1223B-L Landing Light Rib as shown in Figure 3.

Step 3: On the right wing, route the WH-B212 (WHT) Nav Power Wire, WH-B203 (WHT) Strobe Power Wire and WH-B318 (WHT) Strobe Synch Wire that will go to the green LN-200-1 Wing Tip Nav/Position/Strobe Light through the snap bushings in the W-1223B-L & -R Landing Light Ribs and through the snap bushing in the most outboard rib into the wing tip. See Figure 3.

Step 4: On the right wing route the WH-B213 (WHT) Pulse Power Wire and WH-B214 (WHT) Landing Light Power Wire through the snap bushing in the W-1223B-L Landing Light Rib.

Step 5: Pull the WH-B213 (WHT) Pulse Power Wire and WH-B214 (WHT) Landing Light Power Wire out through the landing light cutout in the W-1203-R Outbd Wing Skin, trim them to equal length, strip the ends of the wires then crimp on female Molex pins.

Step 6: Snap the Molex pins on the ends of the WH-B213 (WHT) Pulse Power Wire and WH-B214 (WHT) Landing Light Power Wire into the female Molex connector housing on the end of the WH-B215 (WHT) Landing Light Ground Wire. See Figure 3. The pin locations are not critical.

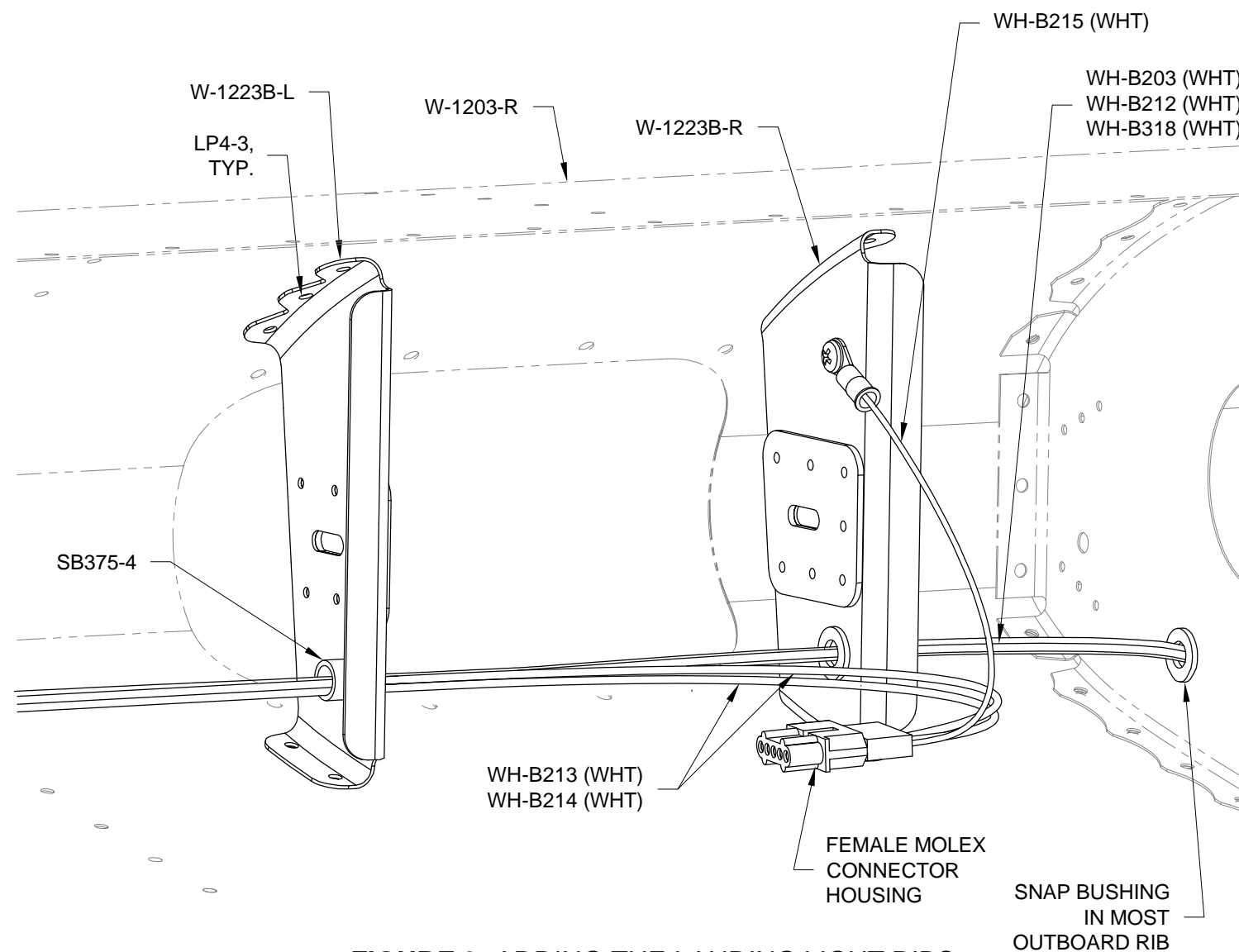
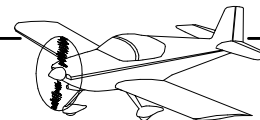

FIGURE 3: ADDING THE LANDING LIGHT RIBS (VIEW FROM INSIDE THE WING)



Step 1: Strip the ends of the wires coming from the back of the LL-200 Landing Light.

Crimp on male Molex pins to the end of each wire.

Step 2: Snap the Molex pin on the end of the black wire coming from the LL-200 Landing Light into the female Molex connector housing opposite the WH-B215 (WHT) Landing Light Ground Wire.

Step 3: Snap the Molex pin on the end of the red wire coming from the LL-200 Landing Light into the female Molex connector housing opposite the WH-B214 (WHT) Landing Light Power Wire.

Step 4: Snap the Molex pin on the end of the yellow wire coming from the LL-200 Landing Light into the female Molex connector housing opposite the WH-B213 (WHT) Pulse Power Wire.

Step 5: Snap the Molex pins on the remaining blue and green wires coming from the LL-200 Landing Light into the two remaining pin locations in the female Molex connector housing. These wires are not used and have no associated wires in the other half of the Molex connector housing.

Step 6: Connect the male and female Molex connector housings for the LL-200 Landing Light. Add tie-wraps as necessary.

Step 7: Install the LL-200 Landing Light onto the W-1223B-L & -R Landing Light Ribs using the hardware called out in Figure 1. First align the attach holes in the landing light with the aft end of the slot in the landing light ribs, start the bolt with washers by hand then slide the landing light forward to the front of the slots.

Aim the light slightly downward so that the front face of the landing light is parallel to the front edge of the landing light ribs.

Finish tightening the bolts using a box end wrench while continuing to hold the front face of the landing light parallel to the front edge of the landing light ribs. See Figure 1.

Step 8: Use two pieces of double backed tape or equivalent adhesive to hold the W-1223E Lens Backing Strips to the inside face of the W-00014 Lens. See Figure 2.

Step 9: Slip the W-00014 Lens through the landing light cutout in the W-1203-R Outbd Wing Skin and screw it in place as shown in Figure 2.

Use tape to make temporary pull tabs to help start the screws.

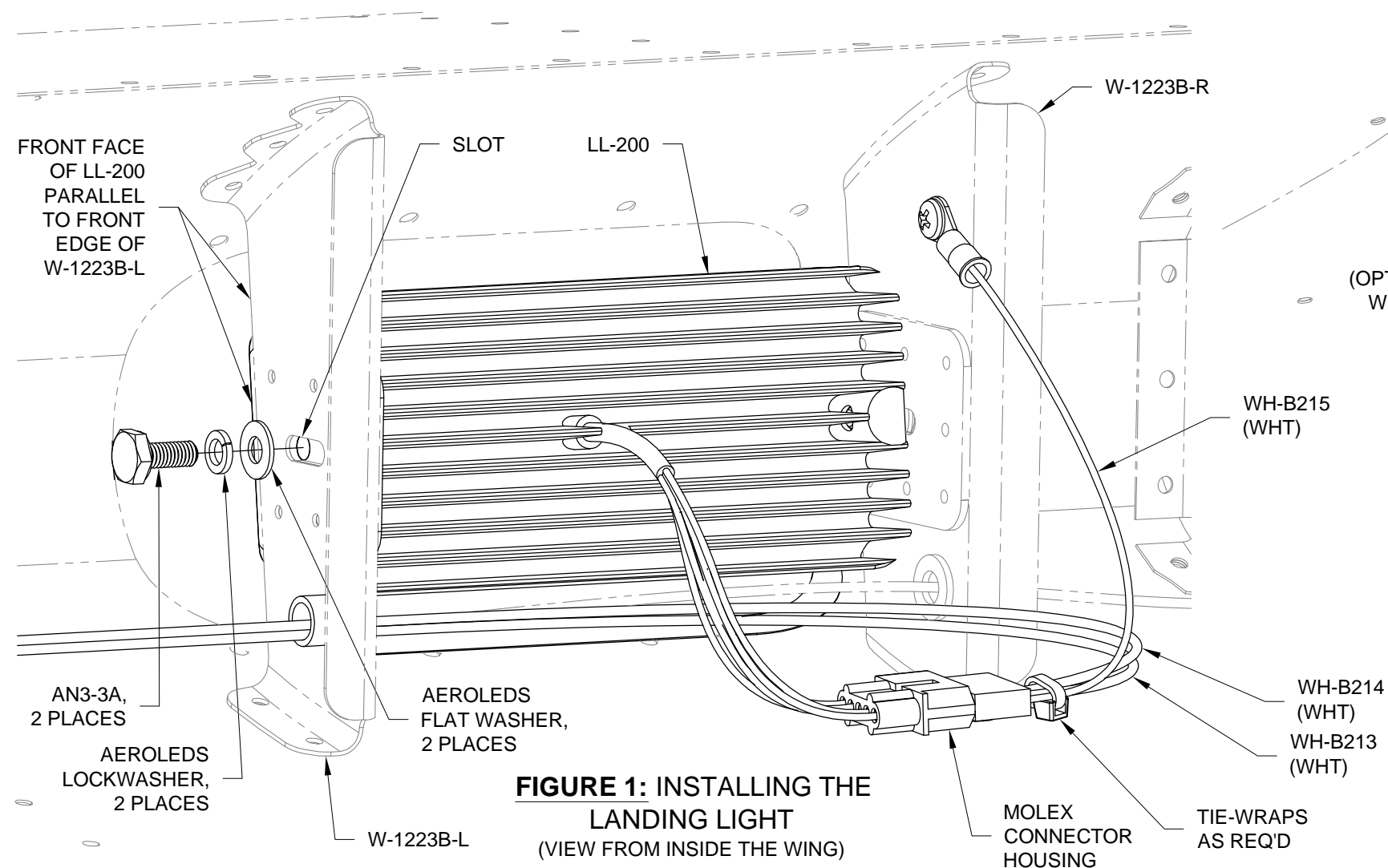

FIGURE 1: INSTALLING THE LANDING LIGHT
(VIEW FROM INSIDE THE WING)

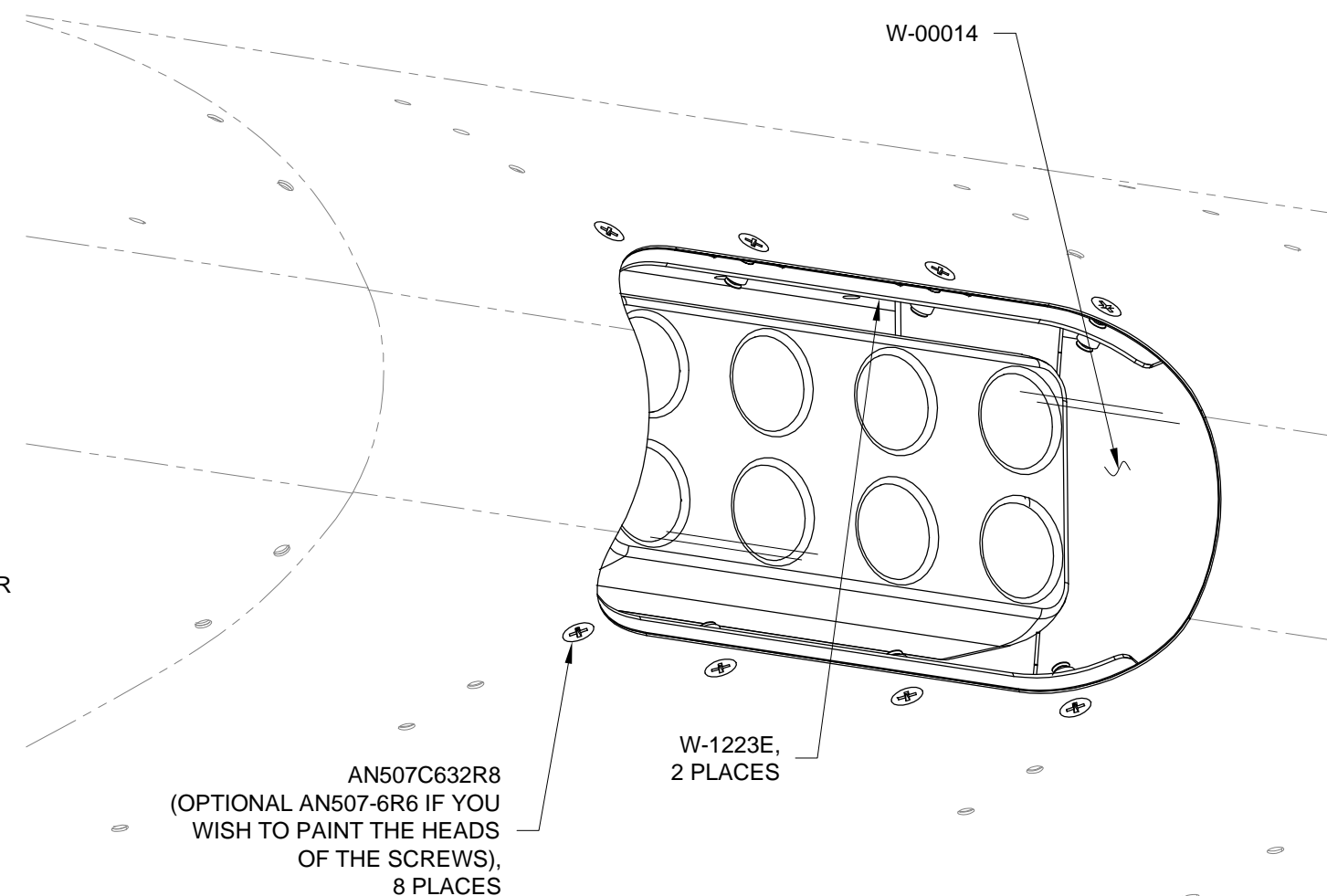
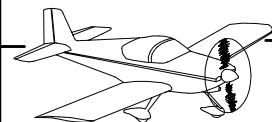

FIGURE 2: INSTALLING THE LENS



Step 1: Trim the W-1222-L & -R Extensions back to within 1/16 of the scribe lines defining the part perimeter with a hand shear, then sand the extensions back to the scribe line.

Step 2: Fit the W-1222-L & -R Extensions to each wing tip then drill #30 the forward two and aft two holes into the upper flange and the W-1204E-L & -R Fwd Wing Tip Ribs.

Remove the extensions and clear any drill chips then cleco back in place.

Drill #30 all the hole locations into the lower flange and into the W-1204D Wing Tip Close-Out.

Match-Drill #30 the three holes already in the wingtip (a bright light may help in revealing the hole locations underneath the fiberglass).

Step 3: Cover each wing tip in the area around where the flox on the W-1222-L & -R Extensions will touch with a release agent such as car wax. See Figure 1 and Figure 2.

Add a glob of modeling clay or wax to the area where a nut will be placed (see Figure 1 and Figure 2).

Step 4: Turn both wings upside down.

Step 5: Prepare approximately 2-3 fluid oz. of flox/epoxy resin mixture. Mix in flox until the concoction is just thick enough to not pour from the cup.

Step 6: Fill cavities in the upper flange of the W-1222-L & -R Extensions that abut the W-1204E-L & -R Fwd Wing Tip Ribs. See Figure 2 with flox/epoxy resin mixture, then cleco the extensions to the F-1204D Wing Tip Close-Outs.

Immediately clean any flox/epoxy resin mixture that may have squeezed out.

Step 7: When the flox has set up, drill #30 the top center two holes into the W-1204E-L & -R Fwd Wing Tip Ribs.

Step 8: Remove the W-1222-L & -R Extensions from each wing tip.

Sand away any of the flox that may have squeezed out around the perimeter of the part. Remove the modeling clay plug.

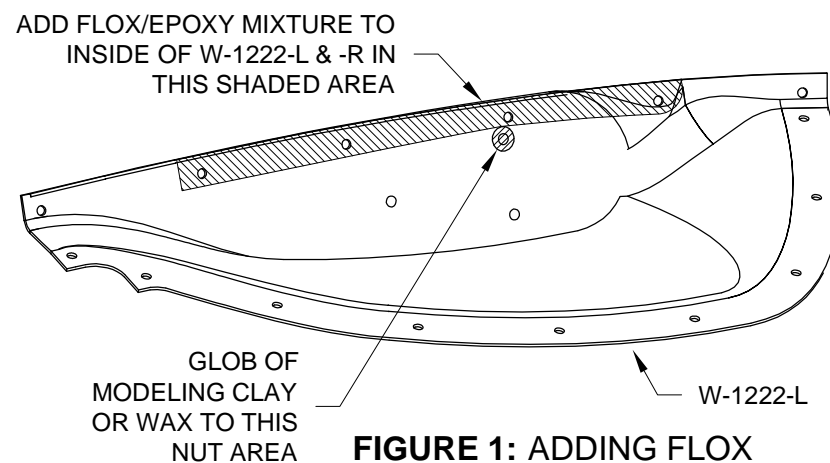

FIGURE 1: ADDING FLOX

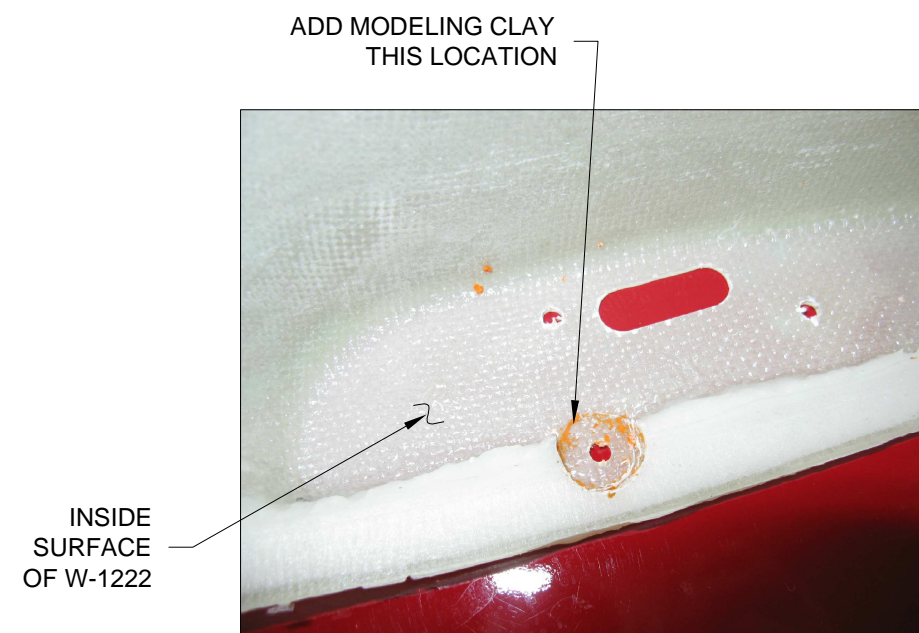

FIGURE 2: DETAIL OF NUT RECESS

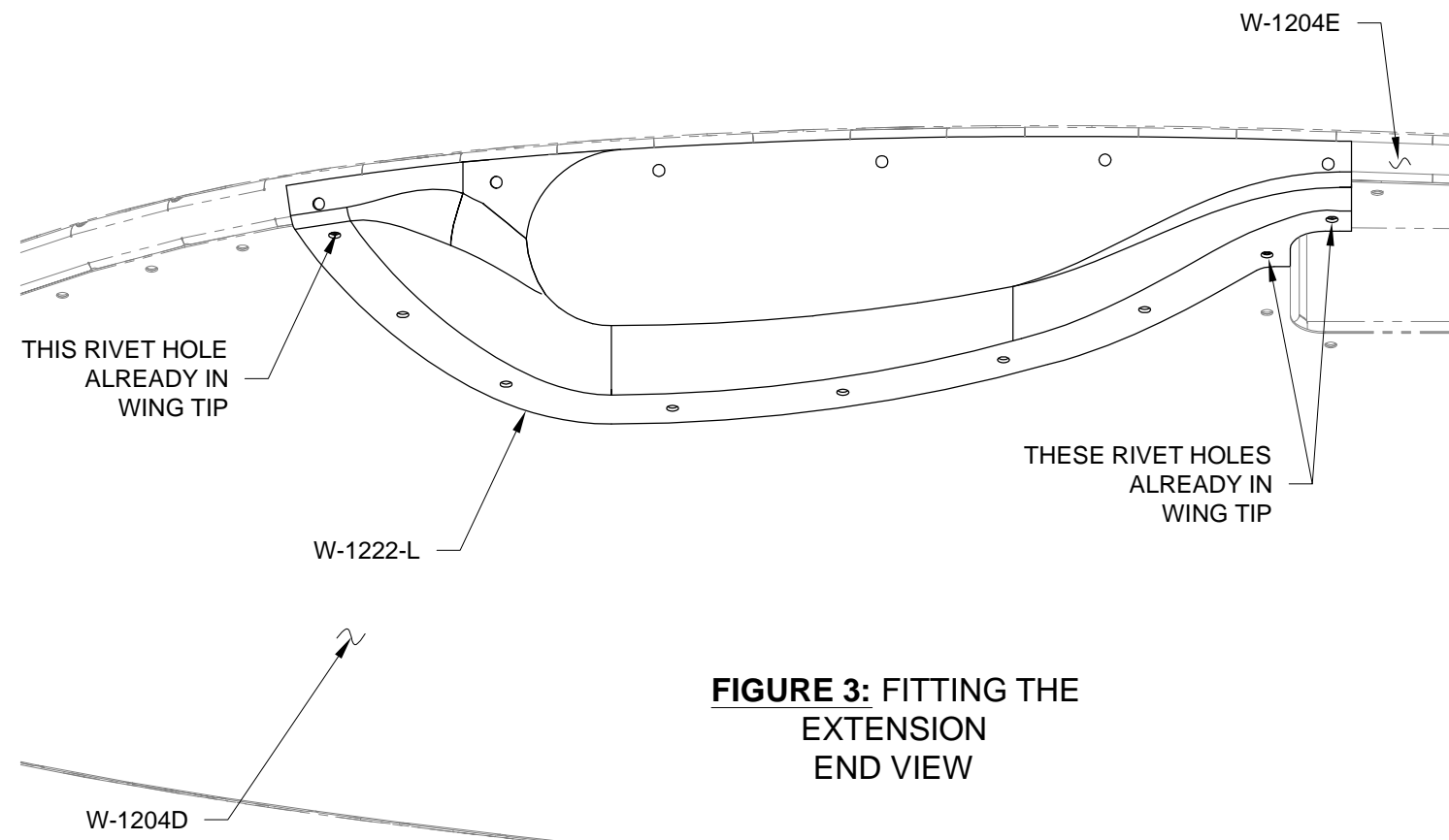
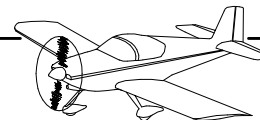

FIGURE 3: FITTING THE EXTENSION END VIEW



Step 1: Use the dimples molded in the flat face of the W-1222-L & -R Extensions to align the LN-200-1 Wing Tip Nav/Position/Strobe Light mount brackets.

Clamp the mount bracket in place on each extension, then match-drill #27 the holes in the mount bracket into the extensions. See Figure 1.

Step 2: Drill #30, then use a step-drill bit to enlarge the access hole called out in Figure 1.

Step 3: Machine countersink 120° all the attach holes in the upper flange of the W-1222-L & -R Extensions for the head of a CS4 rivet.

Finish the edges of the part. If your wing tip is already painted this is a good time to paint the extensions.

Step 4: Attach the wing tip nav/position/strobe light mount brackets to the extensions using the hardware shown in Figure 1.

Step 5: Fabricate two WH-B211 (WHT) Nav/Strobe Ground Wires by cutting two pieces of 18 gauge wire 6 inches long.

Strip both ends of the wires. On one end of the wire crimp the ring terminal shown in Figure 2.

On the remaining end of the wire crimp a female Molex pin.

Step 6: Attach the ring terminal on the end of the WH-B211 (WHT) Nav/Strobe Ground Wires to the hole in the W-1204D Wing Tip Close-Outs using the hardware called out in Figure 2.

Step 7: Trim and strip the WH-B212 (WHT) Nav Power Wires, WH-B203 (WHT) Strobe Power Wires, WH-B318 (WHT) Strobe Synch Wires in each wing tip to match the length of the WH-B211 (WHT) Nav/Strobe Ground Wires.

Crimp a female Molex pin onto the end of each wire.

Step 8: Snap the female Molex pins on the ends of the WH-B211 (WHT) Nav/Strobe Ground Wire and WH-B212 (WHT) Nav Power Wire, WH-B203 (WHT) Strobe Power Wire, and the WH-B318 (WHT) Strobe Synch Wire into a male Molex connector housing in each wing tip.

Step 9: Tie-Wrap all four wires together near the ring terminal on each wing tip to prevent the wires from rubbing on the edge of the access opening as shown in Figure 2.

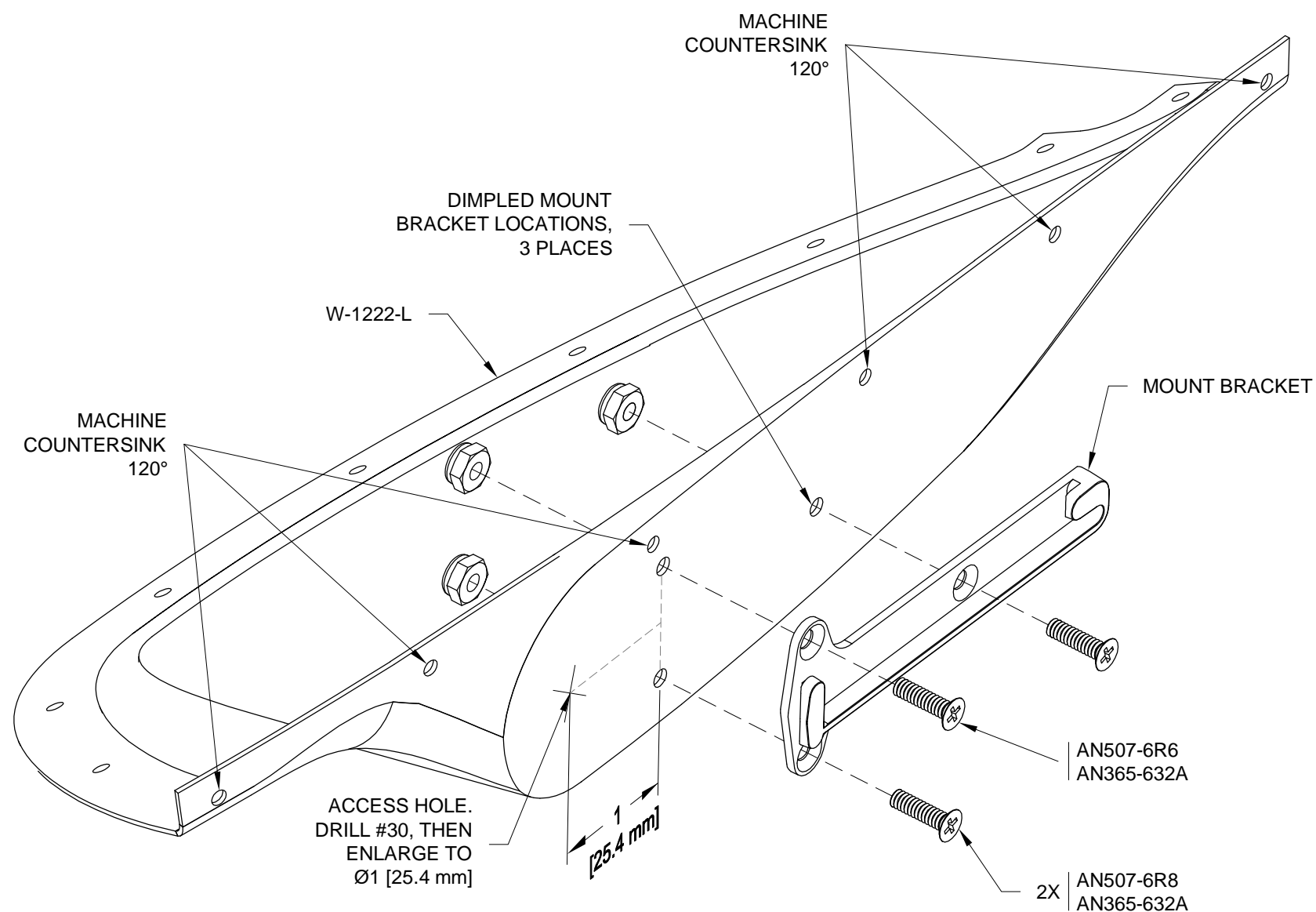

FIGURE 1: FINISHING THE EXTENSIONS

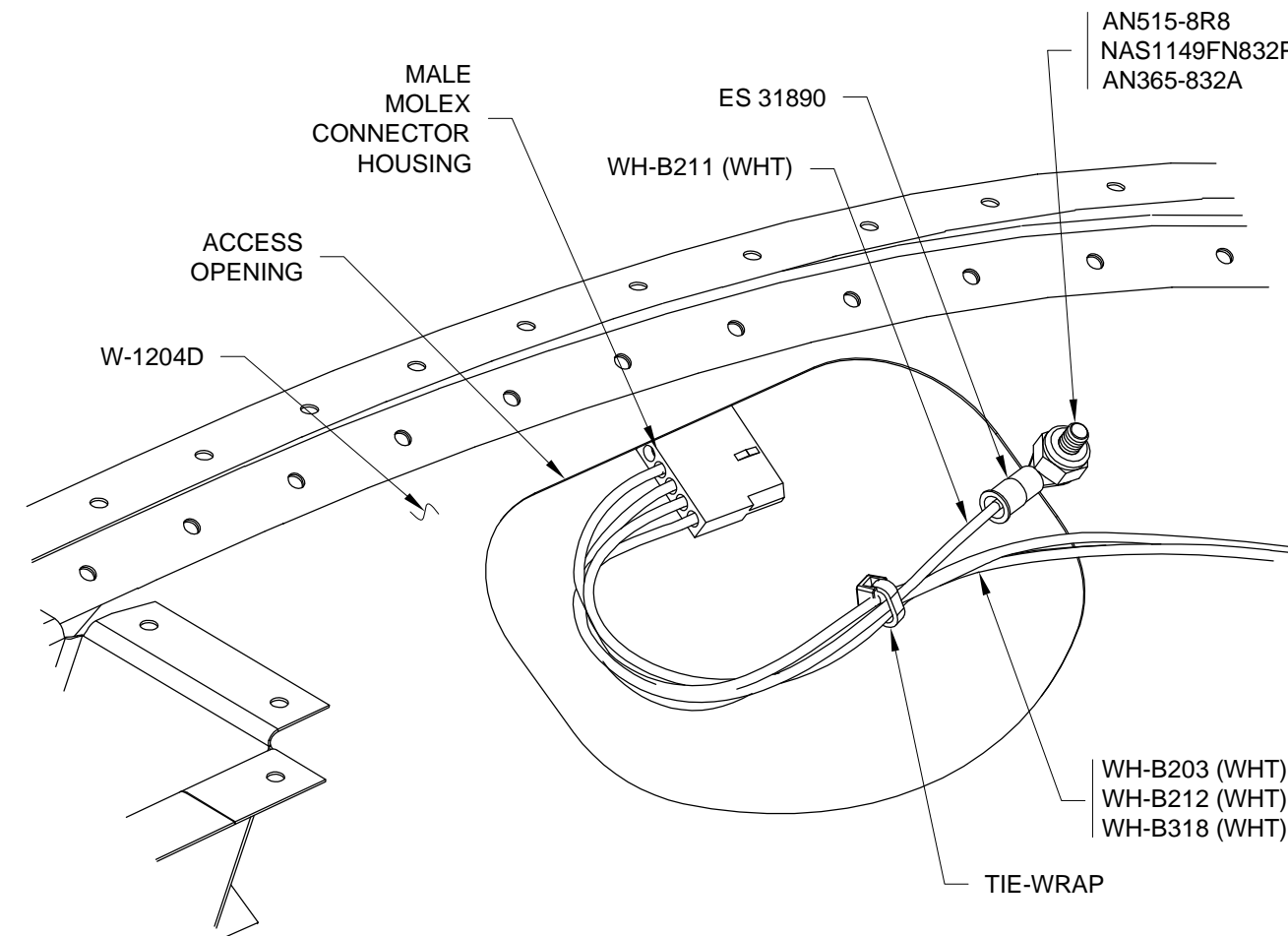

FIGURE 2: NAV/STROBE WIRE VIEW
(WING TIP TOP SKIN NOT SHOWN FOR CLARITY)



Step 1: Cleco the W-1222-L & -R Extensions to the wing tips.

Step 2: Add a layer of electrical tape onto the W-1204D Wing Tip Close-Outs as shown in Figure 2 offset from the lower flange of the extensions by 1/32 of an inch. See Figure 1.

Step 3: Cut a narrow strip of electrical tape then add it along the edge of the extension. See Figure 1.

Step 4: Remove the W-1222-L & -R Extensions from the wing tips and add a thin layer of fuel tank sealant on the lower flange that interfaces with the W-1204D Wing Tip Close-Outs.

Step 5: Pull the male Molex connector housings through the access hole in the W-1222-L & -R Extensions, then cleco and rivet the extensions to the wing tips. See Figure 1.

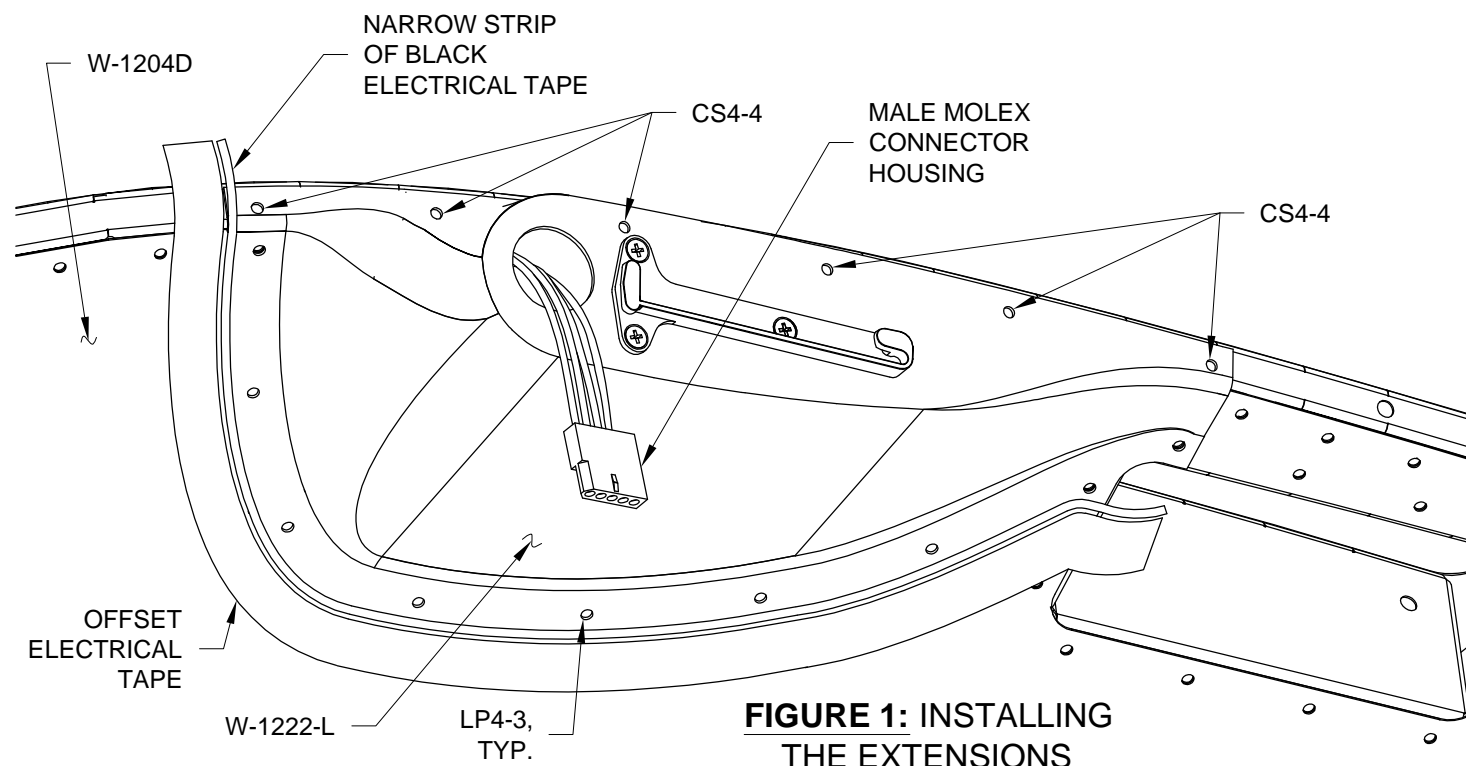

FIGURE 1: INSTALLING THE EXTENSIONS

Step 6: Create a popsicle stick tool as shown in Figure 2.

Step 7: Use the radiused corner of the popsicle stick to fillet the fuel tank sealant that extrudes out around the lower flange of the W-1222-L & -R Extensions. When satisfied with the appearance remove the tape as soon as possible before the sealant sets up leaving a crisp edge.

NOTE: The red light (with a red sticker on the bottom) goes on the left wing tip.

Step 8: Crimp male Molex pins on the ends of all the wires coming from the LN-200-1 Wing Tip Nav/Position/Strobe Lights.

Step 9: Snap the male Molex pin on the end of the black wires coming from each wing tip nav/position/strobe light into a female Molex connector housing opposite the position of each WH-B211 (WHT) Nav/Strobe Ground Wire.

Step 10: Snap the male Molex pin on the end of the red wires coming from each wing tip nav/position/strobe light into the female Molex connector housing opposite the position of each WH-B212 (WHT) Nav Power Wire.

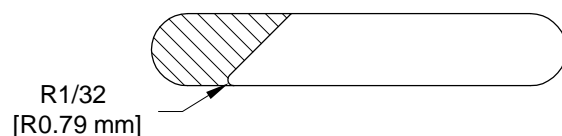

FIGURE 2: POPSICLE STICK TOOL

Step 11: Snap the male Molex pin on the end of the yellow wires coming from each wing tip nav/position/strobe light into the female Molex connector housing opposite the position of the WH-B203 (WHT) Strobe Power Wire.

Step 12: Snap the male Molex pin on the end of the green wires coming from each wing tip nav/position/strobe light into the female Molex connector housing opposite the position of the WH-B318 (WHT) Strobe Synch Wire.

Step 13: Label the Molex connector housings as to which wire goes in what position.

Step 14: Connect the Molex connector housings together for the wing tip nav/position/strobe lights.

Slide the wires and connector housings back into the wing tip through the access hole in the W-1222-L & -R Extensions then slide the lights onto the mount brackets and tighten them in place with the set screw at the aft edge.

Step 15: Install the Nav/Strobe Fuse as shown on Page 42M-03, Figure 1.

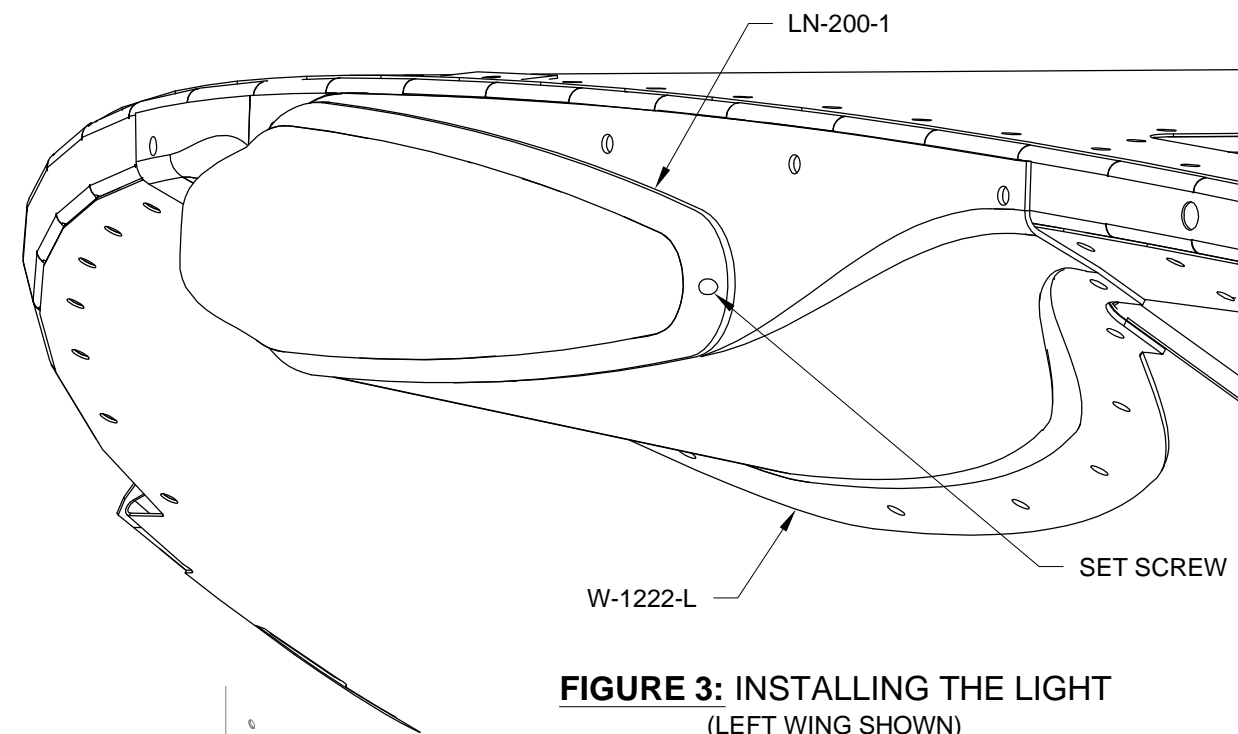

FIGURE 3: INSTALLING THE LIGHT (LEFT WING SHOWN)

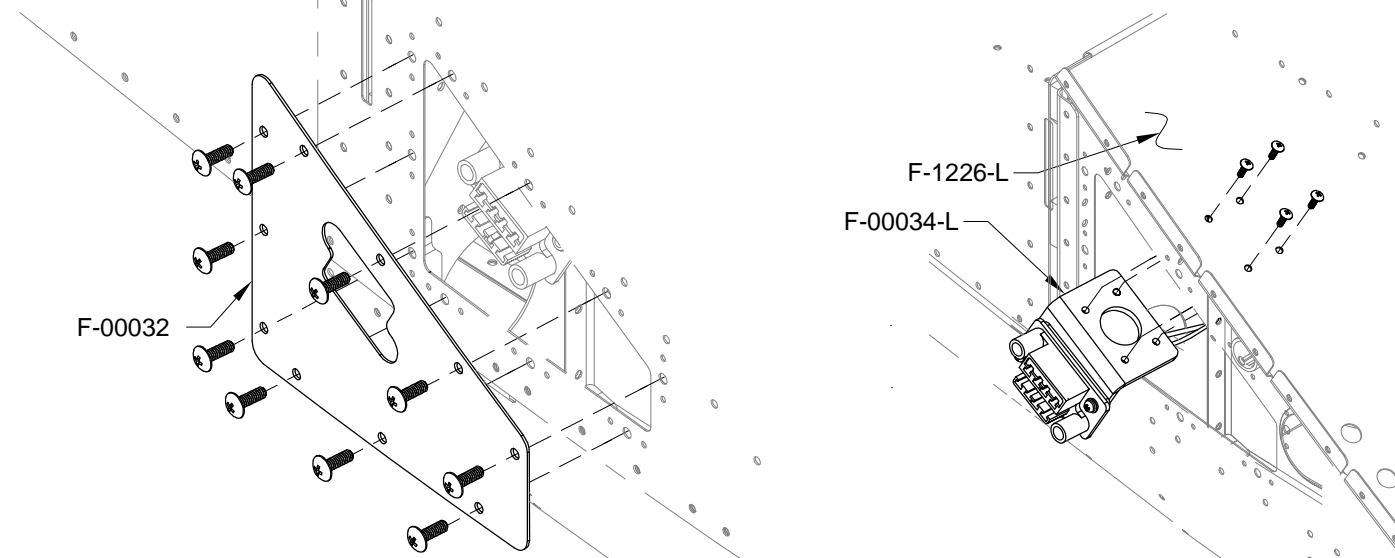
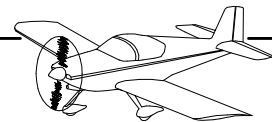

FIGURE 4: LEFT SIDE COVER ASSEMBLY VIEW

FIGURE 5: BRACKET ASSEMBLY VIEW



Step 1: Remove the F-00032 Fuselage Side Cover from the left side of the aircraft as shown on Page 40-10, Figure 4.

Step 2: Remove the F-00034-L Wing Electrical Bracket from the F-1226-L Seat Ramp as shown on Page 40-10, Figure 5.

Step 3: Remove the F-1227 Seat Ramp Cover as shown on Page 33-02, Figure 4.

Step 4 (D180 EFIS): Connect the female spade connector from the ES-00103 Noise Filter to the male spade connector on the WH-P274 (WHT) Lighting Power Update Wire as shown in Figure 1.

Connect the male spade connector from the noise filter to the WH-L72 (YEL/RED)/WH-B184 (WHT) Nav/Strobe Power Wires as shown in Figure 1.

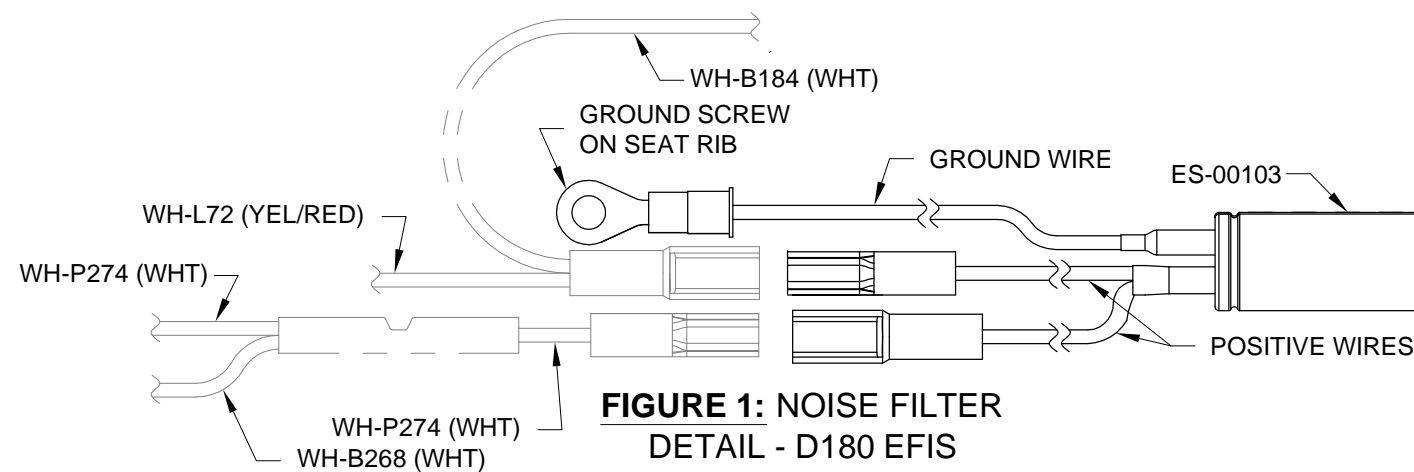

**FIGURE 1: NOISE FILTER
DETAIL - D180 EFIS**

Step 4 (SV-D1000 EFIS): Connect the female spade connector from the ES-00103 Noise Filter to the male spade connector on the WH-P274 (WHT) Lighting Power Update Wire. See Figure 2.

Connect the male spade connector from the noise filter to the WH-L457 (WHT/YEL) Strobe Power Wire. See Figure 2.

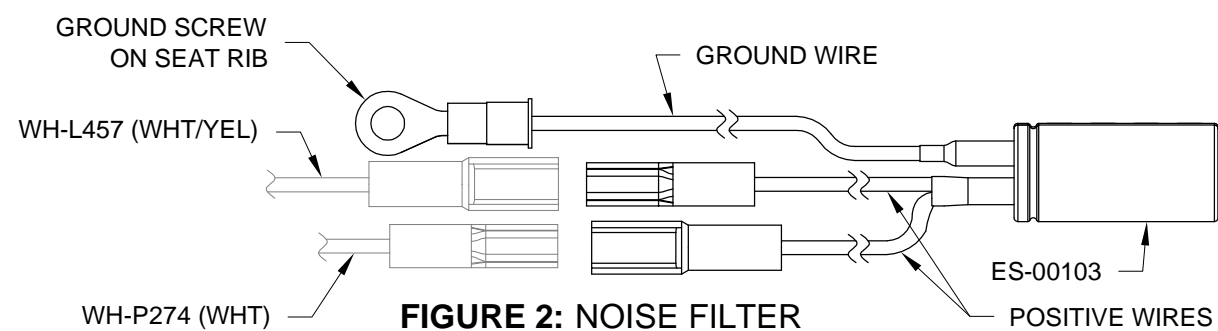

**FIGURE 2: NOISE FILTER
DETAIL - SV-D1000 EFIS**

Step 5: Attach the ring terminal on the ES-00103 Noise Filter to the F-1215-L Seat Rib tooling hole using the hardware shown in Figure 3. If the seat rib has been primed, remove the primer in the local area of the ring terminal to insure a proper ground.

Removing the F-1227 Seat Ramp Cover in Step 3 allows access each side of the seat rib. If you are having trouble reaching or do not have the proper tools to install the ring terminal to the tooling hole on the seat rib, drill #19 a new ground hole location in the region shown in Figure 3.

Step 6: Reinstall the F-00034-L Wing Electrical Bracket.

Step 7: Tie-wrap the ES-00103 Noise Filter to the wire bundle going to the ES-00077 Floating 8 Pos Connector Female as shown in Figure 4. Add additional tie wraps as required. Make sure that the wires do not rub on the F-1253 Seat Floor Support.

Step 8: Reinstall the F-1227 Seat Ramp Cover and the F-00032 Fuselage Side Cover.

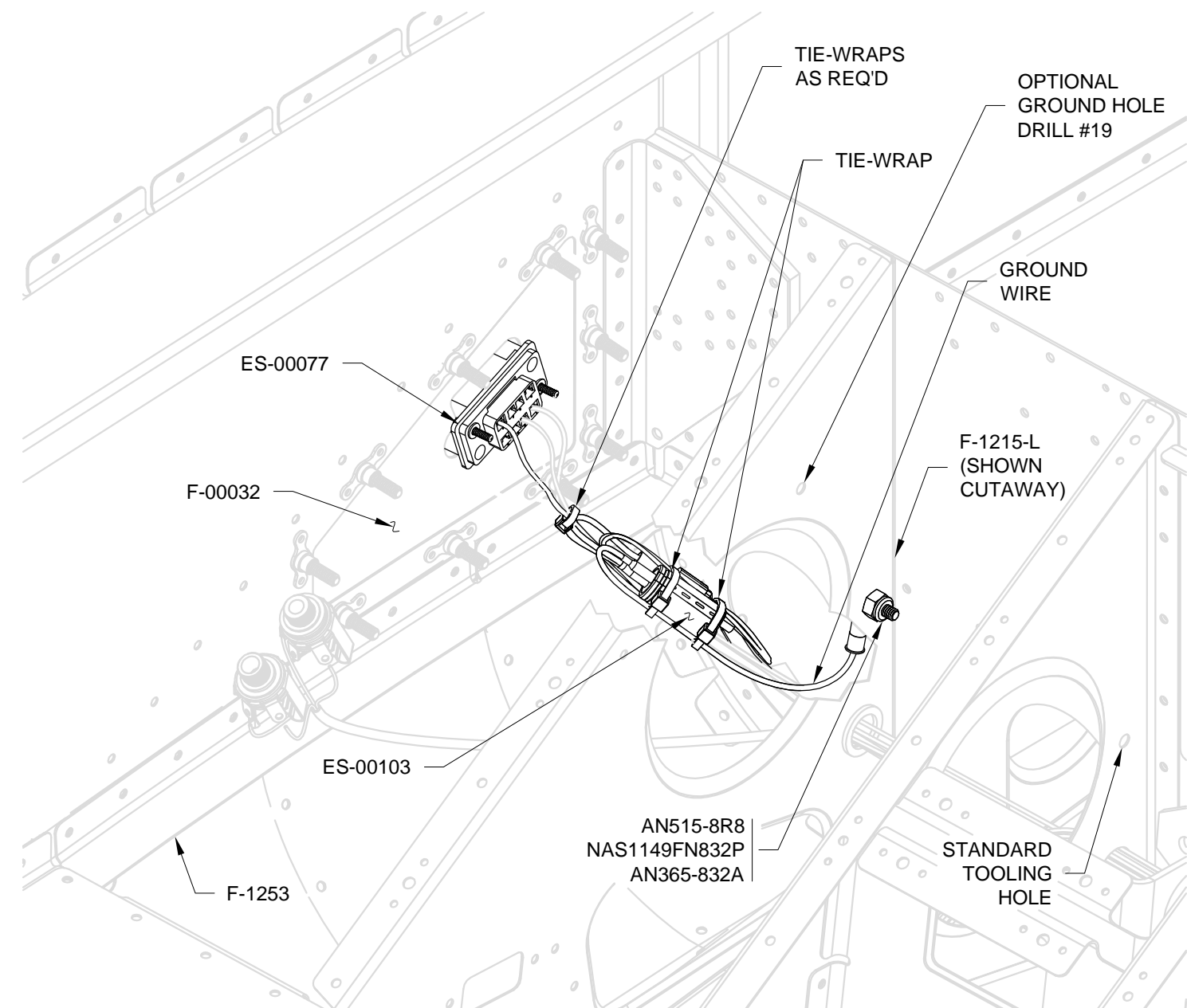

**FIGURE 3: STROBE NOISE
FILTER INSTALL
(SOME DETAILS OMITTED FOR CLARITY)**



NOTE: This page is for the D180 installation.

NOTE: The WH-B179 (WHT) Cockpit Light Power Wire, WH-B180 (WHT) Cockpit Light Ground Wire, and F-12126 Wire Tube may already be installed and routed up through the roll bar assembly.

Step 1: Drill #12 a hole in the bottom of the Roll Bar Assembly at the location shown in Figure 2.

Step 2: Insert a snap bushing in the hole just made in the bottom of the Roll Bar Assembly as shown in Figure 2. The flange of the bushing will need to be trimmed away to allow the bushing to fit between the F-1231A-AR & FR Roll Bar Frames and fully snap in place.

Step 3: Remove the two lower right rivets that hold the F-1231A-FR Roll Bar Frame and F-1231E Roll Bar Splice Plate together using a #30 bit. See Figure 1.

Step 4: Machine countersink the three holes in the F-12124 Light Bracket for attaching the LC ECL-02 Red Eyeball Cockpit Light.

Step 5: Cleco the F-12124 Light Bracket to the holes from the rivets just removed in Step 3.

Step 6: Match-Drill #30 the right two holes in the F-12124 Light Bracket into the web of the F-1231A-FR Roll Bar Frame.

Step 7: Prep and Paint the F-12124 Light Bracket.

Rivet the light bracket to the web of the F-1231A-FR Roll Bar Frame as shown in Figure 1.

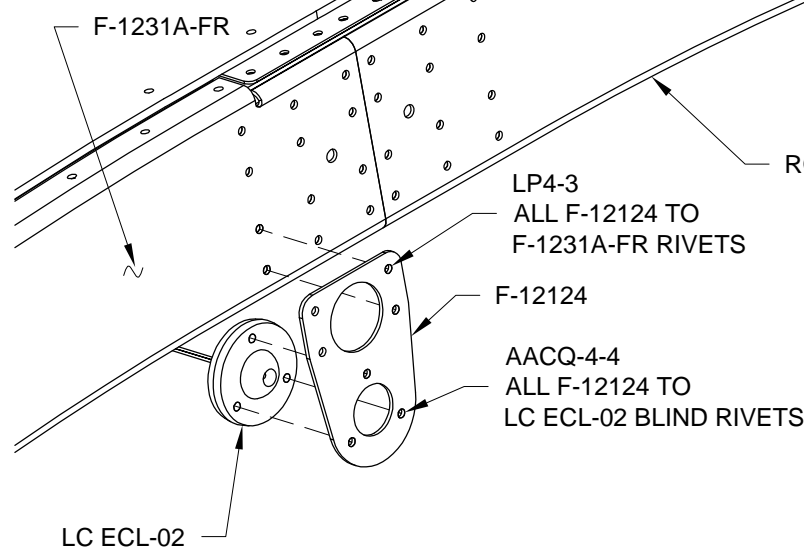

FIGURE 1: ADDING THE LIGHTING BRACKET

Step 8: Crimp on butt splices as shown in Figure 2 to each of the two wires coming out of the LC ECL-02 Red Eyeball Cockpit Light.

Step 9: Fabricate a WH-B179 (WHT) Cockpit Light Power Wire and WH-B180 (WHT) Cockpit Light Ground Wire by cutting two pieces of 22 gauge wire each 153 inches long.

Step 10: Crimp the WH-B179 (WHT) Cockpit Light Power Wire into the butt splice on the red wire coming from the LC ECL-02 Red Eyeball Cockpit Light.

Crimp the WH-B180 (WHT) Cockpit Ground Wire into the butt splice on the black wire coming from the red eyeball cockpit light.

Step 11: Rivet the LC ECL-02 Red Eyeball Cockpit Light to the F-12124 Light Bracket per the hardware in Figure 1.

Step 12: Attach the splices attached to the LC ECL-02 Red Eyeball Cockpit Light to the rollbar structure and light housing with a dab of fuel tank sealant or hot glue etc.

Step 13: Remove the F-1240 Assembly Skin as shown on Page 29A-05, Figure 4.

Step 14: Enlarge the guide hole in the F-1205B Roll Bar Attach Plate to Ø3/8 using a step drill. The hole will need to be enlarged from the bottom side. See Figure 3.

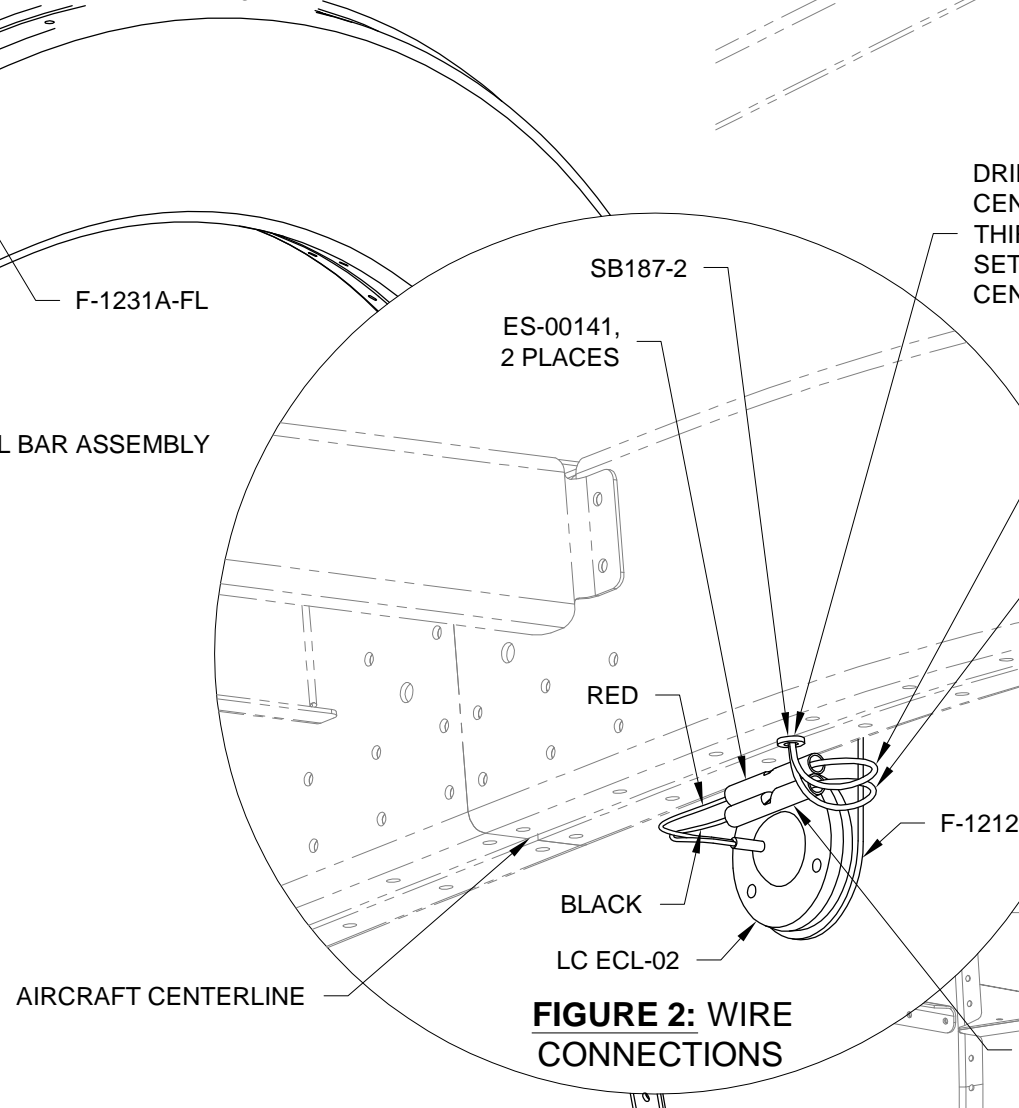

FIGURE 2: WIRE CONNECTIONS

Step 15: Insert a snap bushing into the hole just made in the F-1205B Roll Bar Attach Plate. See Figure 3.

Step 16: Fabricate the F-12126 Wire Tube by cutting a 30 inch long piece of PT-035X1/4 plastic tube.

Step 17: Curve the ends of the WH-B179 (WHT) Cockpit Light Power Wire and WH-B180 (WHT) Cockpit Ground Wire, then insert the ends through the snap bushing in the bottom of the Roll Bar Assembly.

Push the wires down through the Roll Bar Assembly, route them through the large hole at the base of the roll bar on the aft side.

Slide the F-12126 Wire Tube over the wires and back into the Roll Bar Assembly as shown in Figure 3.

Slide the wires through the snap bushing in the F-1205B Roll Bar Attach Plate.

Follow the routing of the WH-Q54 (ORN/BRN) Fuel Level Wire described in Section 31B back up through the F-1202B Panel Base.

Step 18: Crimp the WH-B179 (WHT) Cockpit Light Power Wire into the open end of the butt splice with the WH-L80 (YEL/PRP) and WH-F177 (RED) wires crimped in the other end. See Section 31B.

Step 19: Crimp the WH-B180 (WHT) Cockpit Light Ground Wire into the open end of the butt splice with the WH-L82 (YEL/GRN) and WH-F178 (BLK) wires crimped in the other end. See Section 31B.

Step 20: Reinstall the F-1240 Assembly Skin.

NOTE: The EFIS must be powered up for the cockpit light to be active.

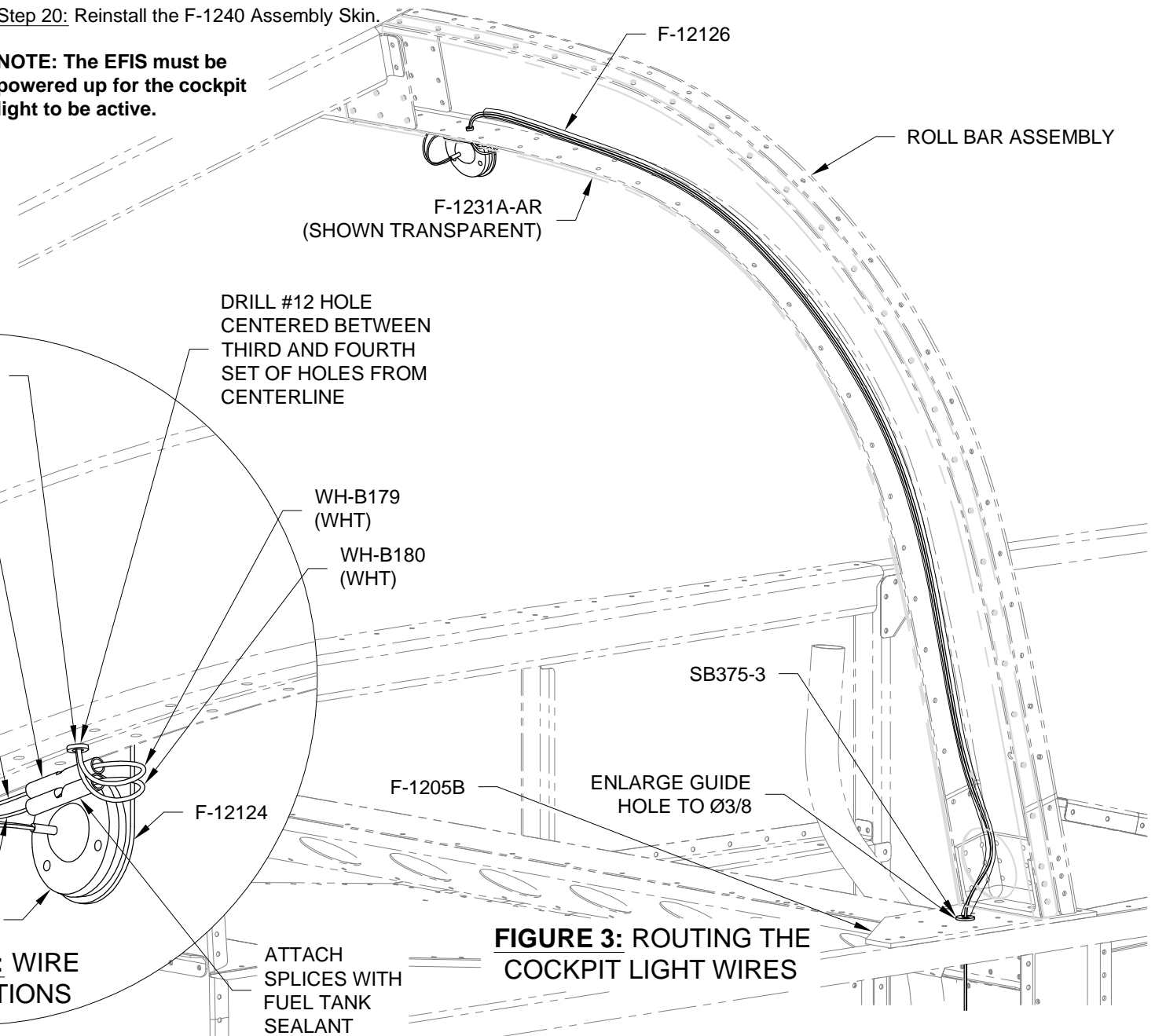
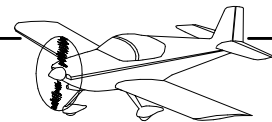

FIGURE 3: ROUTING THE COCKPIT LIGHT WIRES



NOTE: This page is for the Skyview D-1000, or G3X installation.

NOTE: The WH-L435 (YEL/PRP) Cockpit Light Power Wire, WH-L436 (YEL/GRN) Cockpit Ground Wire, and F12126 Wire Tube may already be installed and routed up through the roll bar assembly.

Step 1: Drill #12 a hole in the bottom of the Roll Bar Assembly at the location shown in Figure 2.

Step 2: Insert a snap bushing in the hole just made in the bottom of the Roll Bar Assembly as shown in Figure 2. The flange of the bushing will need to be trimmed away to allow the bushing to fit between the F-1231A-AR & FR Roll Bar Frames and fully snap in place.

Step 3: Remove the two lower right rivets that hold the F-1231A-FR Roll Bar Frame and F-1231E Roll Bar Splice Plate together using a #30 bit. See Figure 1.

Step 4: Machine countersink the three holes in the F-12124 Light Bracket for attaching the LC ECL-02 Red Eyeball Cockpit Light.

Step 5: Cleco the F-12124 Light Bracket to the holes from the rivets just removed in Step 3.

Step 6: Match-Drill #30 the right two holes in the F-12124 Light Bracket into the web of the F-1231A-FR Roll Bar Frame.

Step 7: Prep and Paint the F-12124 Light Bracket.

Rivet the light bracket to the web of the F-1231A-FR Roll Bar Frame as shown in Figure 1.

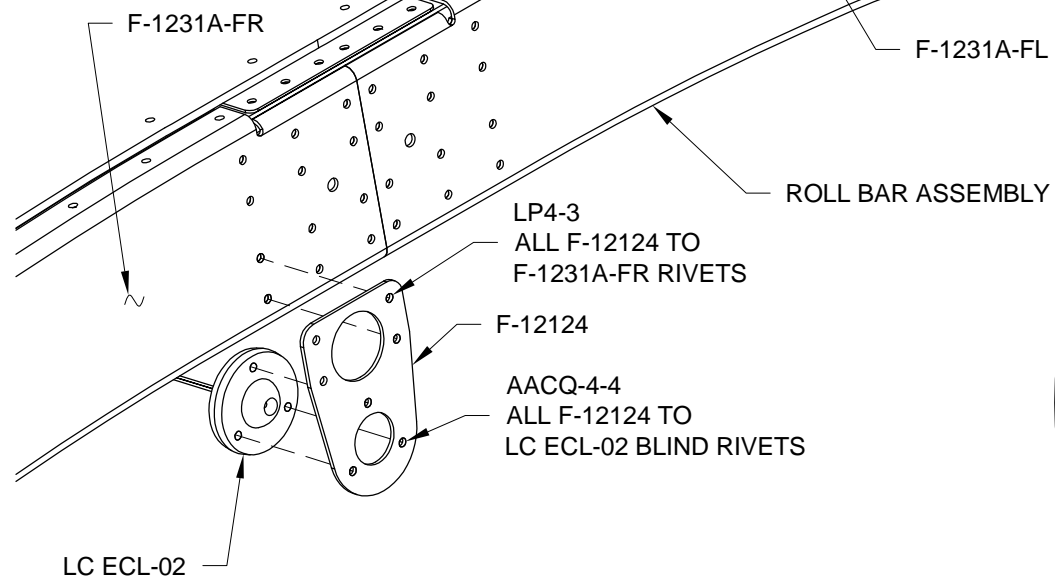

FIGURE 1: ADDING THE LIGHTING BRACKET

Step 8: Crimp on butt splices as shown in Figure 2 to each of the two wires coming out of the LC ECL-02 Red Eyeball Cockpit Light.

Step 9: Rivet the LC ECL-02 Red Eyeball Cockpit light to the F-12124 Light Bracket per the hardware in Figure 1.

Step 10: Enlarge the guide hole in the F-1205B Roll Bar Attach Plate to Ø3/8 using a step drill. The hole will need to be enlarged from the bottom side. See Figure 3.

Step 11: Insert a snap bushing into the hole just made in the F-1205B Roll Bar Attach Plate. See Figure 3.

Step 12: Uncoil the WH-L435 (YEL/PRP) Cockpit Light Power Wire and WH-L436 (YEL/GRN) Cockpit Ground Wire Stowed near the ELT in Section 31B.

Slide the WH-L435 (YEL/PRP) Cockpit Light Power Wire and WH-L436 (YEL/GRN) Cockpit Ground Wire through the snap bushing in the F-1205B Roll Bar Attach Plate.

Step 13: Fabricate the F-12126 Wire Tube by cutting a 30 inch long piece of PT-035X1/4 plastic tube.

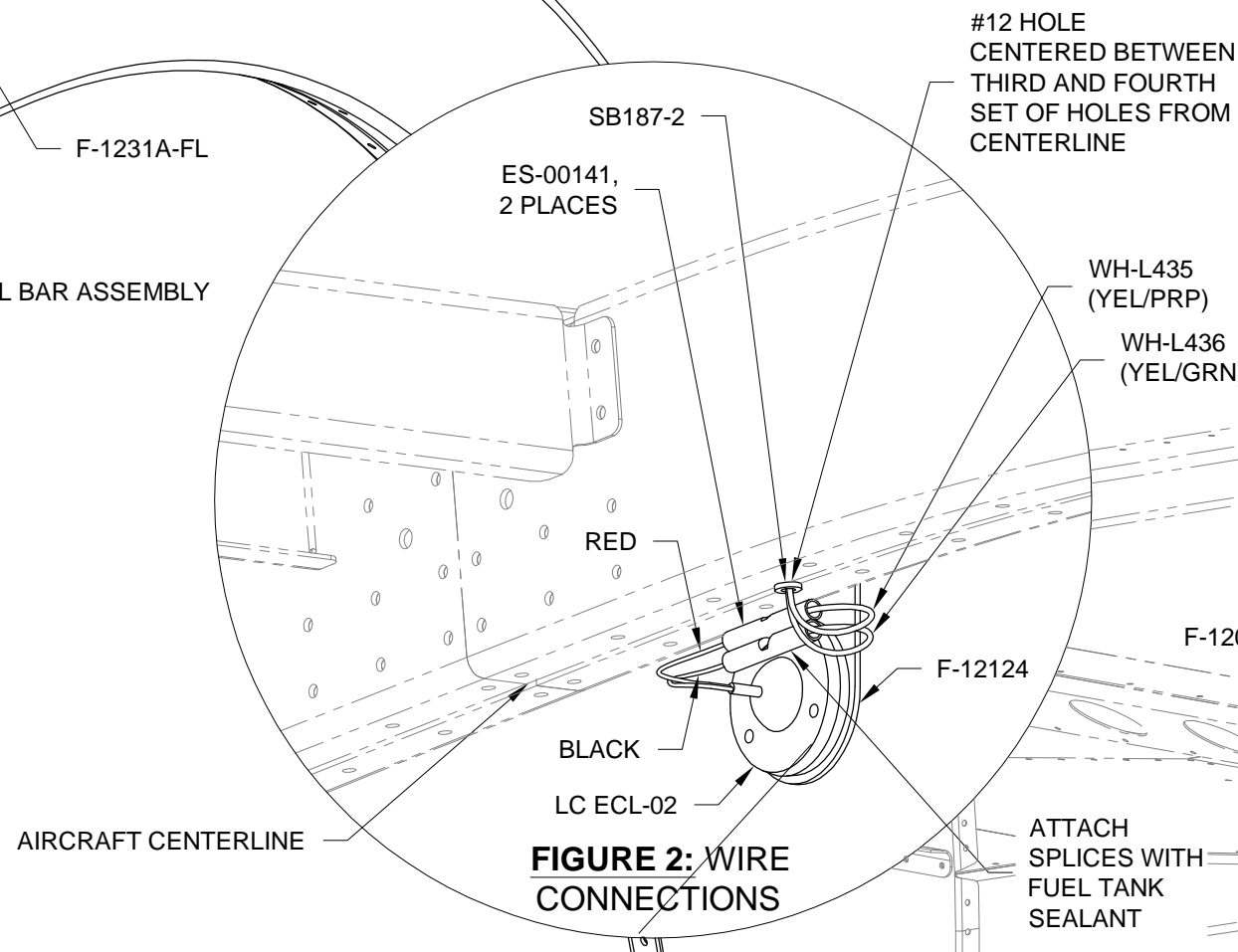

FIGURE 2: WIRE CONNECTIONS

Slide the wire tube over the WH-L435 (YEL/PRP) Cockpit Light Power Wire and WH-L436 (YEL/GRN) Cockpit Ground Wire.

Step 14: Route a piece of safety wire through the #12 hole made in Step 1 and down through the Roll Bar Assembly to the large hole at the base of the Roll Bar Assembly on the aft side as shown in Figures 2 & 3.

Tape the safety wire to the WH-L435 (YEL/PRP) Cockpit Light Power Wire, and WH-L436 (YEL/GRN) Cockpit Ground Wire.

Pull the cockpit light power wire, cockpit ground wire and F-12126 Wire Tube up into the Roll Bar Assembly with the safety wire. Stop when the cockpit light power wire and cockpit ground wire has exited the #12 hole as shown in Figures 2 & 3.

Step 15: Crimp the WH-L435 (YEL/PRP) Cockpit Light Power Wire into the butt splice on the red wire coming from the LC ECL-02 Red Eyeball Cockpit Light.

Step 16: Crimp the WH-L436 (YEL/GRN) Cockpit Ground Wire into the butt splice on the black wire coming from the red eyeball cockpit light.

Step 17: Attach the splices attached to the LC ECL-02 Red Eyeball Cockpit Light to the rollbar structure and light housing with a dab of fuel tank sealant or hot glue etc.

NOTE: For all installations, the Nav/Strobe switch must be in the NAV or NAV/STROBE position for the cockpit lighting to be active.

NOTE: If no dimmer knob is installed, the EFIS must be powered on for the cockpit light to be active.

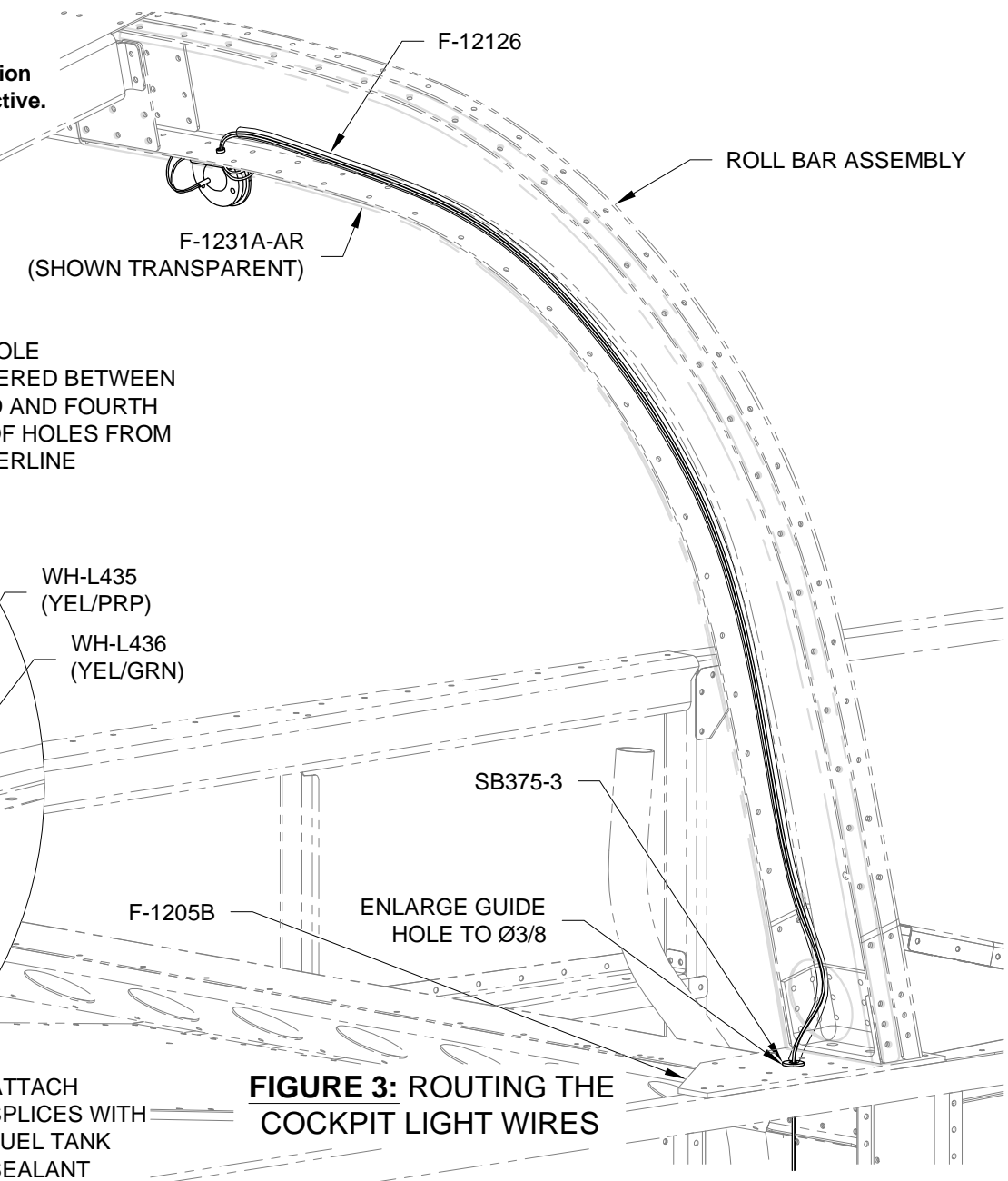
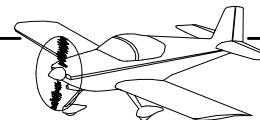

FIGURE 3: ROUTING THE COCKPIT LIGHT WIRES



THIS PAGE INTENTIONALLY LEFT BLANK



NOTE: Any weight and balance information recorded for the aircraft must be updated. Depending on the state of your kit some steps may not be applicable.

Step 1: In the RV-12 Maintenance Manual (MM) "INSTALLED EQUIPMENT LIST" table, add "WING TIP LIGHT & LANDING LIGHT" to the "ITEM" column. On the same line add a checkmark to the "INSTALLED" column.

Enter 2.65 lb for "Weight", 65.83 in for "Location/Arm" and 174.44 in-lb "Moment" onto the same line as "WING TIP LIGHT & LANDING LIGHT".

NOTE: Steps 2-4 on this page are only applicable if a final weight and balance as specified in the PAP has been completed.

Step 2: In the RV-12 Pilot Operating Handbook (POH) "YOUR AIRPLANE" table, enter the new total values for the arm, weight, and moment of the installed equipment.

Step 3: In the RV-12 POH "YOUR AIRPLANE" table, recalculate and enter new values for the Empty Weight, Empty Moment, and Empty Arm.

Step 4: Make an entry, as calculated in the previous step, on the WEIGHT AND BALANCE RECORD page of the RV-12 Maintenance Manual as follows:

As of this date: ___/___/___ the following values represent current Weight and Balance calculations resulting from the installation of the Wing Tip Light & Landing Light Optional Kit.

Revised Empty Weight: _____ lbs

Revised Empty Moment: _____ in-lbs

Revised Empty Arm: _____ in

Signed: _____

NOTE: The remaining steps on this page are only applicable for aircraft which have passed a final airworthiness inspection.

Step 5 (ELSA): Make an appropriate entry in the airframe logbook. See example below:

Installed the WING TIP LIGHT & LANDING LIGHT option in accordance with Van's Aircraft KAI Section 40 and confirmed proper operation.

Signature _____ Certificate # _____

Step 5 (SLSA): Complete the notification N 16-10-10 (available from the Van's Aircraft web site) corresponding to the WING TIP LIGHT & LANDING LIGHT installation.

Step 6: Section complete.



THIS PAGE INTENTIONALLY LEFT BLANK

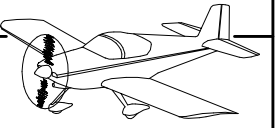

CUT HERE ALLOWING THE
TEMPLATE TO FIT BETWEEN THE
EDGE OF THE W-1204A-R
FORWARD WING TIP SKIN AND THE
RIVETS ATTACHING THE NEXT
INBOARD NOSE RIB.

TOP

BOTTOM

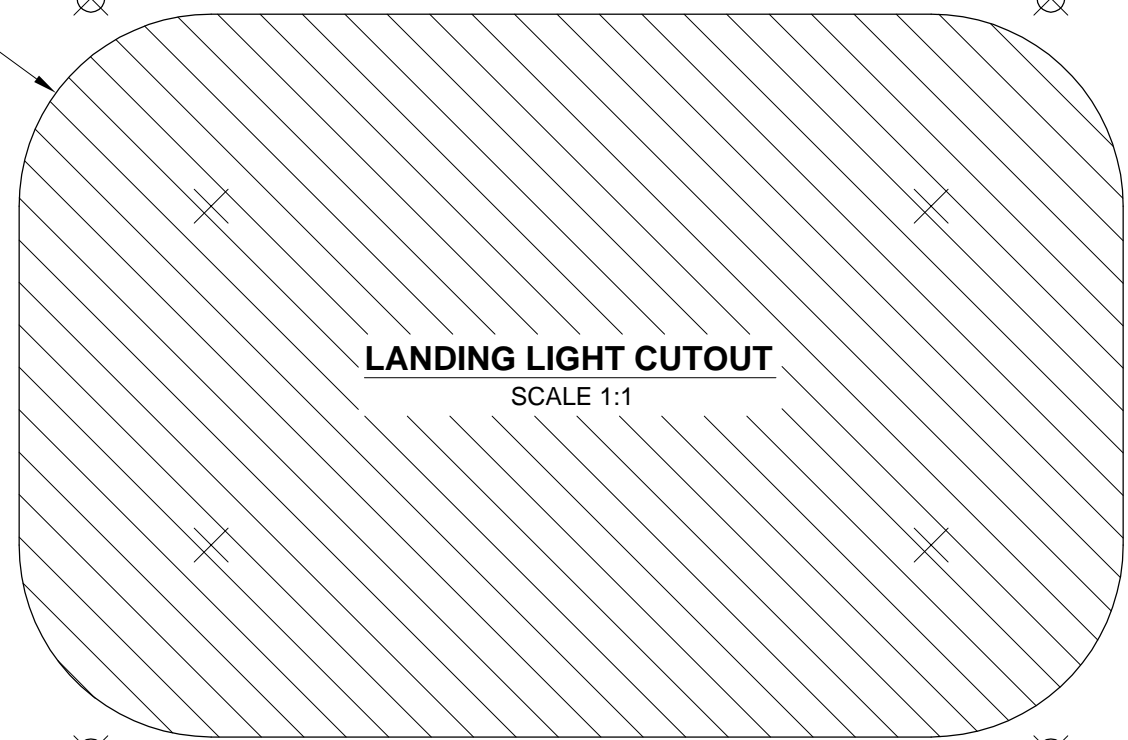

LANDING LIGHT CUTOUT
SCALE 1:1

TOP
LEADING EDGE
RIB RIVETS

(R1
[R25.40 mm]),
TYP

OUTBOARD
EDGE OF W-1203-R

OVERLAPPING EDGE
OF W-1204A-R

BOTTOM
LEADING EDGE
RIB RIVETS

RIVET
HOLES

RIVET
HOLES

SCREW
HOLES

SCREW
HOLES

RIVET
HOLES

RIVET
HOLES

TOP
LEADING EDGE
RIB RIVETS

BOTTOM
LEADING EDGE
RIB RIVETS

INBOARD

10 9/16
[268.29 mm]

16
[406.40 mm]

NOTE: CHECK PRINTED SCALE 1:1 PER SECTION 3 BEFORE USING THE TEMPLATE!



THIS PAGE INTENTIONALLY LEFT BLANK

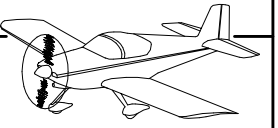

THESE EDGES ALIGN

W-1204D

10 9/16
[268.29 mm]

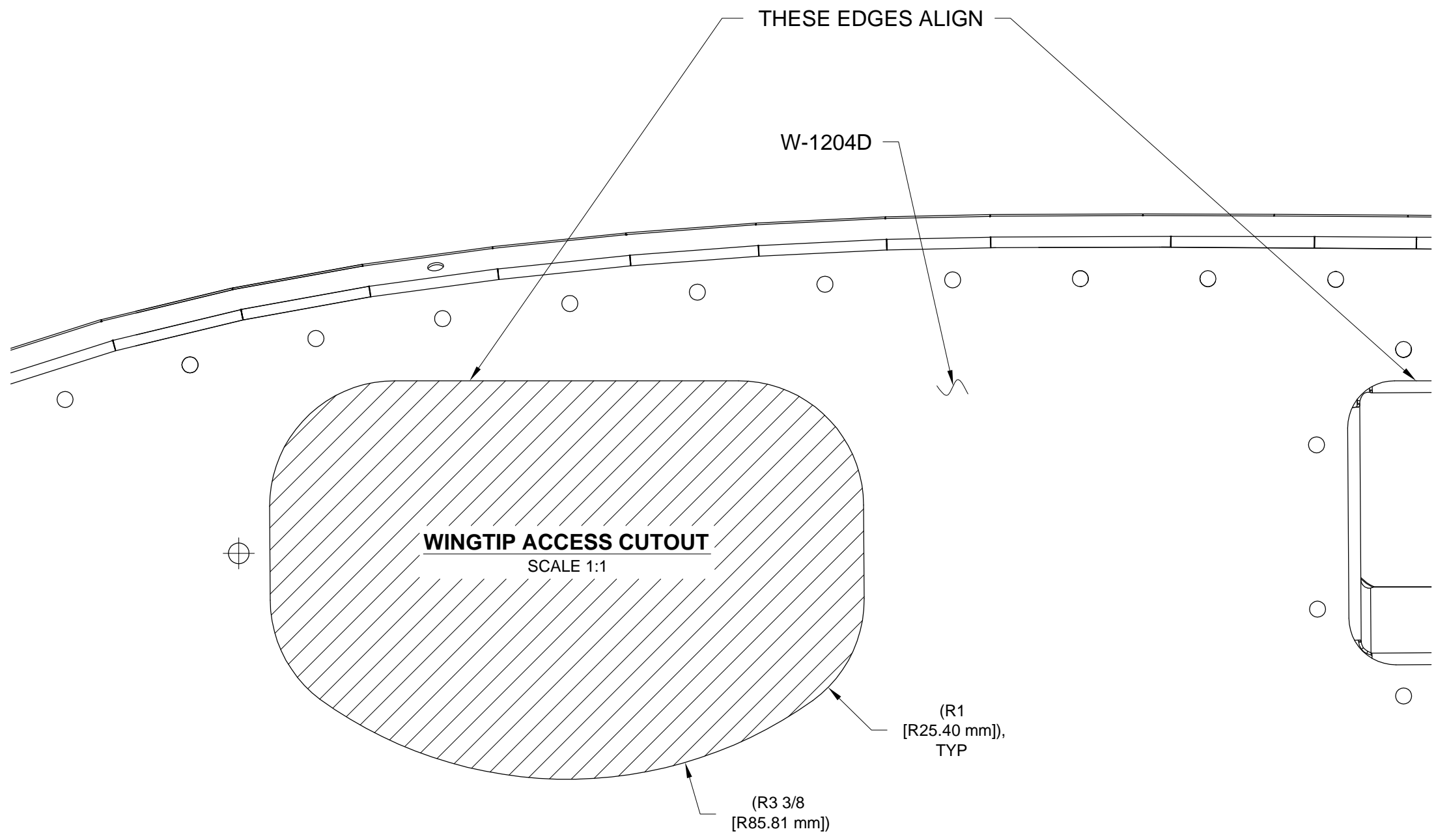

WINGTIP ACCESS CUTOUT
SCALE 1:1

(R1
[R25.40 mm]),
TYP

(R3 3/8
[R85.81 mm])

16

[406.40 mm]

NOTE: CHECK PRINTED SCALE 1:1 PER SECTION 3 BEFORE USING THE TEMPLATE!



THIS PAGE INTENTIONALLY LEFT BLANK