

Step 1: Remove any curve from the F-1287B Doublers if/as required by hammering them until they lay flat. Separate the doublers by removing the material shown hatched in Figure 1. Deburr both parts.

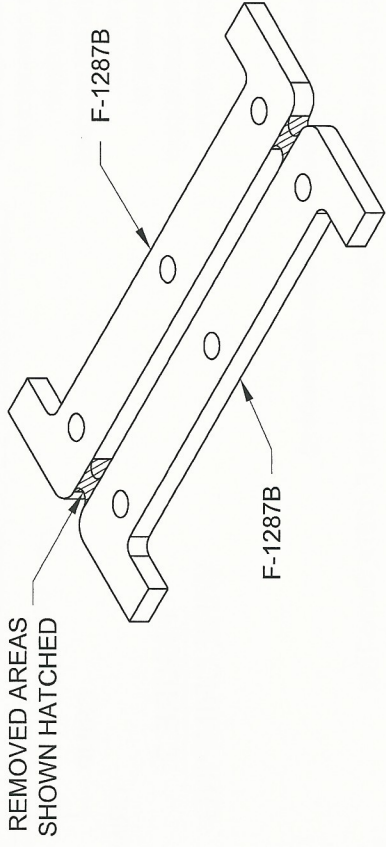

FIGURE 1:
DOUBLER SEPARATION

Step 2: Separate the F-1287J Doublers from the F-1287A Servo Tray by removing the material called out in Figure 2. Deburr parts.

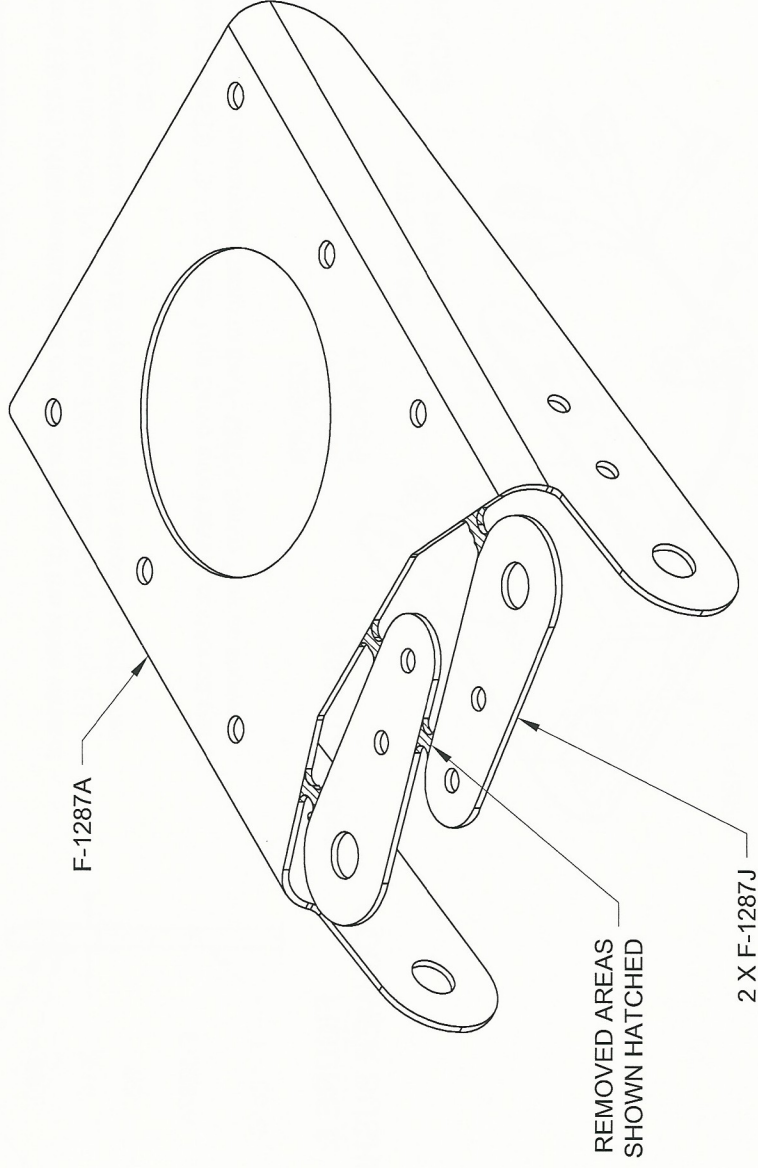

FIGURE 2:
F-1287 SEPARATION

Step 3: Mark then separate the F-1287D-L & -R Clevis Plates by removing the material called out in Figure 3.

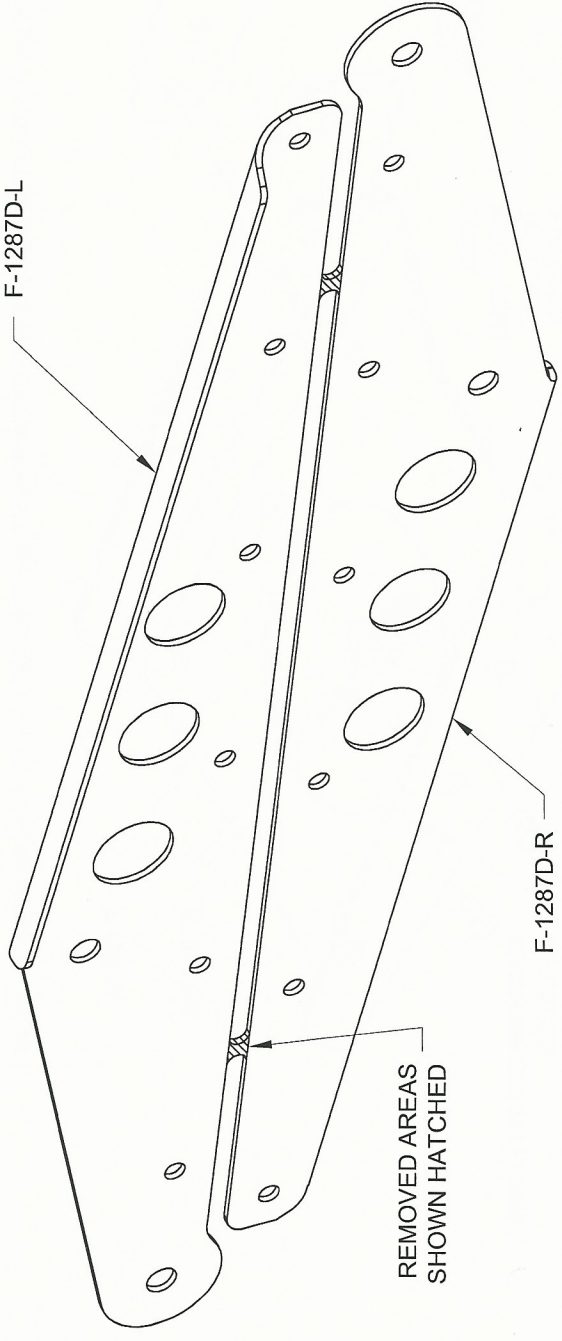

FIGURE 3:
F-1287D CLEVIS PLATE SEPARATION

Step 4: Fabricate the F-1287G and F-1287H Spacers from AT6-058 X 5/16 aluminum tube per the dimensions given in Figure 4.

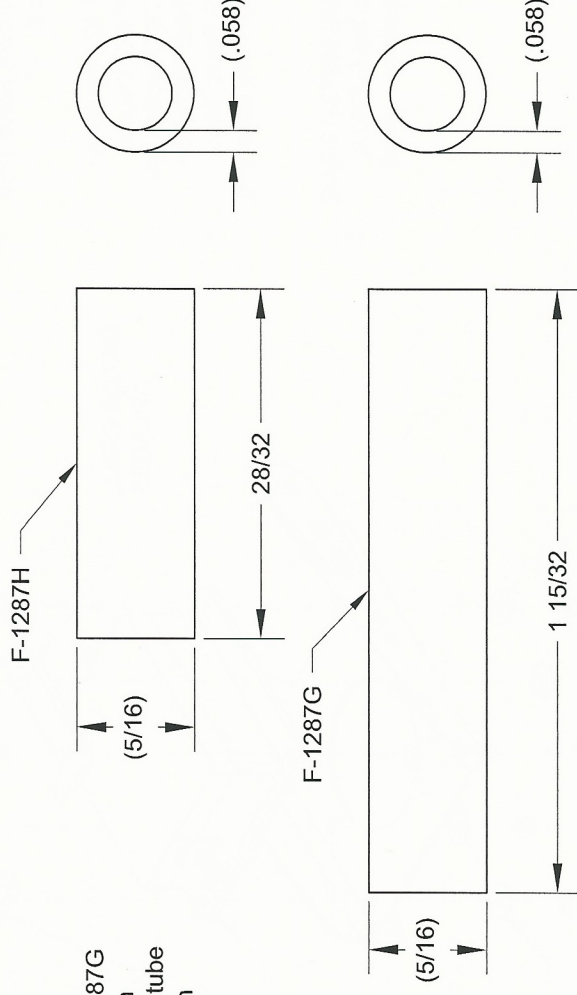

FIGURE 4:
SPACER FABRICATION