

Step 1: Break apart the A-1208 Brackets by removing the hatched areas shown in Figure 1.

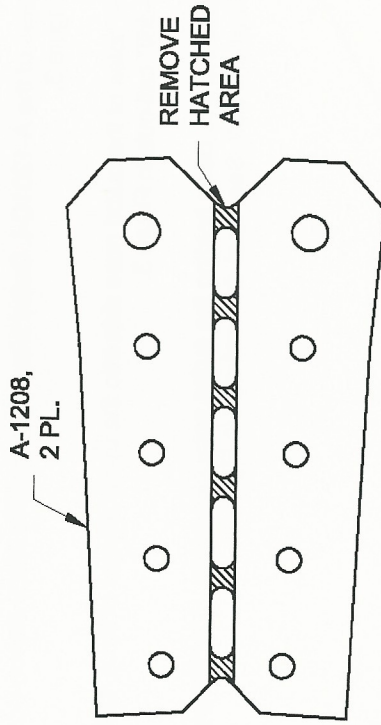

**FIGURE 1: SEPARATING BRACKETS**

Step 2: Deburr the edges of the A-1210-L Inbd Nose Rib. Cleco the A-1208 Bracket to the inbd nose rib as shown in Figure 2.

Step 3: Rivet the A-1208 Bracket to the A-1210-L Inbd Nose Rib per the callouts in Figure 2.

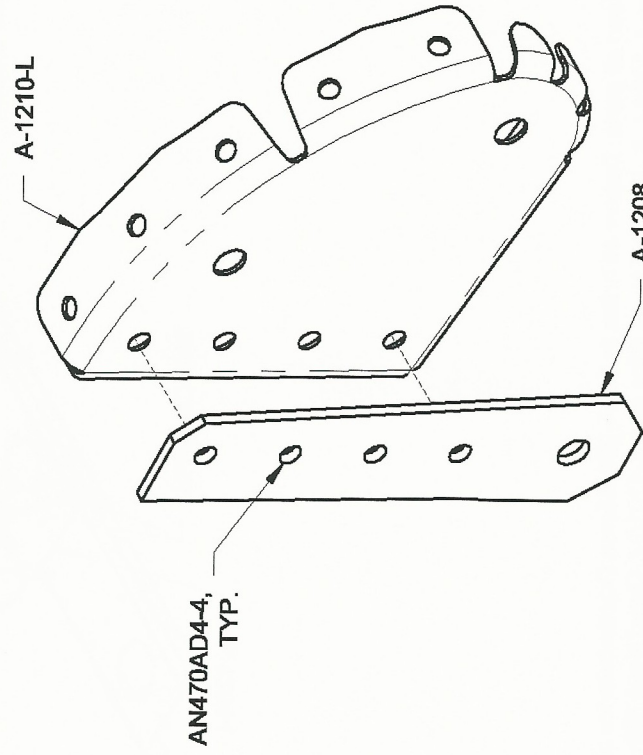

**FIGURE 2:  
INBD NOSE RIB & BRACKET ASSEMBLY**

Step 4: Cleco two A-1206 Pivot Brackets and the Inbd Nose Rib & Bracket Assembly to the A-1203 Spar as shown in Figure 3.

Step 5: Insert an AN3 Bolt through the hole in the A-1208 Bracket and A-1207-L Actuation Bracket. Use washers to space the parts as shown in Figure 3.

Step 6: Align the sides of the A-1207-L Actuation Bracket and A-1206 Pivot Brackets perpendicular with the upper edge of the A-1203 Spar. Match-Drill #30 the holes in the spar into the actuation bracket and pivot brackets. Cleco as you drill.

Step 7: Remove the A-1206 Pivot Brackets, A-1207-L Actuation Bracket, and Inbd Nose Rib & Bracket Assembly from the A-1203 Spar and deburr all holes in all parts that were match-drilled.

Step 8: Inspect the outside edges of all A-1204 Outbd Nose Ribs, and A-1205 Main Ribs, and deburr any edges that are left sharp from the manufacturing process and may scratch the mating skins or spar during final assembly.

Deburr the inboard and outboard edges of the A-1202A & A-1202B Inbd & Outbd Flaperon Skins.

Deburr the aft edges, upper and lower, of the A-1201A, A-1201B, & A-1201C Inbd, Mid, & Outbd Nose Skins.

Prime the A-1206 Pivot Brackets and A-1207-L & -R Actuation Brackets. If desired, all other flaperon parts may be primed at this time.

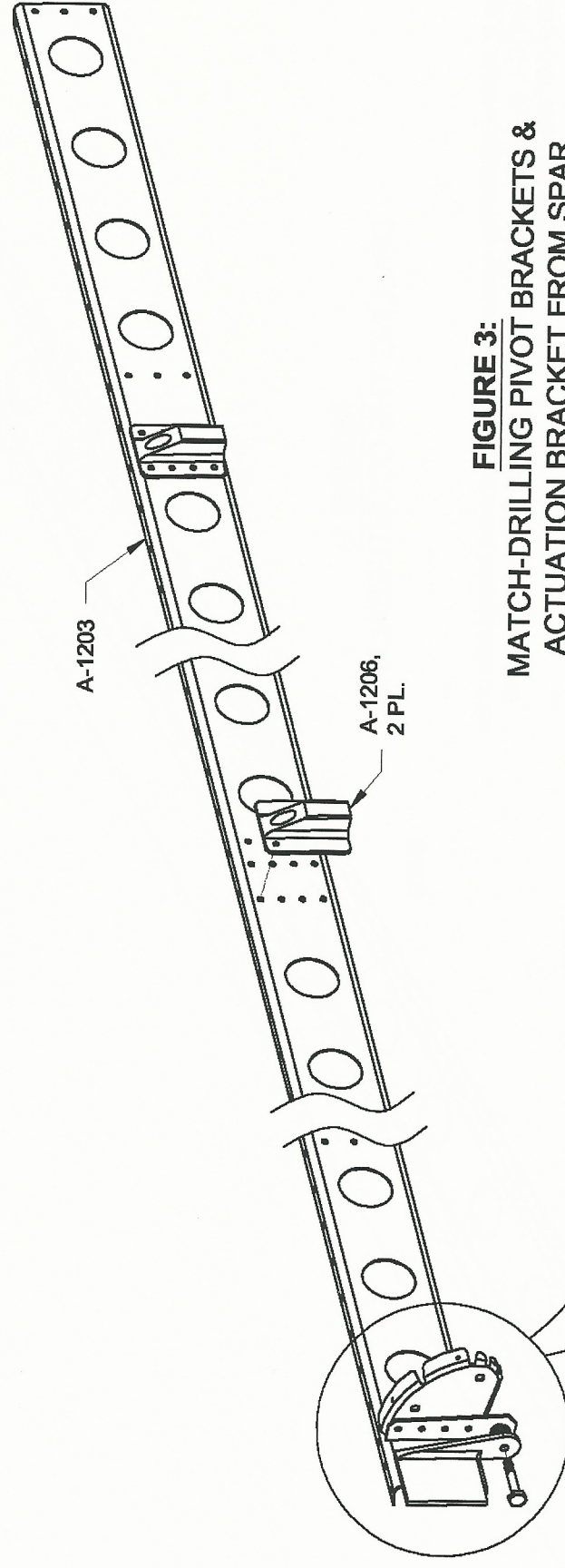

**FIGURE 3:  
MATCH-DRILLING PIVOT BRACKETS &  
ACTUATION BRACKET FROM SPAR**

