

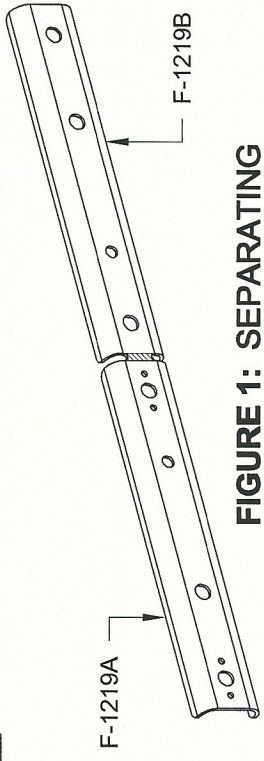

Step 1: Separate the F-1219 Flaperon Mixer Arm by removing the hatched area shown in Figure 1.



**FIGURE 1: SEPARATING THE F-1219 FLAPERON MIXER ARM**

Step 2: Rivet the two F-1218 Flaperon Mixer Brackets to the F-1220A Forward Intercoastal and the F-1220B Aft Intercoastal using the rivets called out in Figure 2.

Step 3: Machine countersink the nutplate attach rivet holes in the F-1219A Flaperon Mixer Arm, then attach the nutplates called out in Figure 2.

Step 4: Bolt the F-1219A & B Flaperon Mixer Arms and the bushing called out in Figure 2 to the F-1218 Flaperon Mixer Brackets using the hardware shown. Torque the bolt enough to remove any slop or play, but still allow freedom of rotation.

Step 5: Bolt the second, longer bushing called out in Figure 2 between the F-1219A & B Flaperon Mixer Arms.

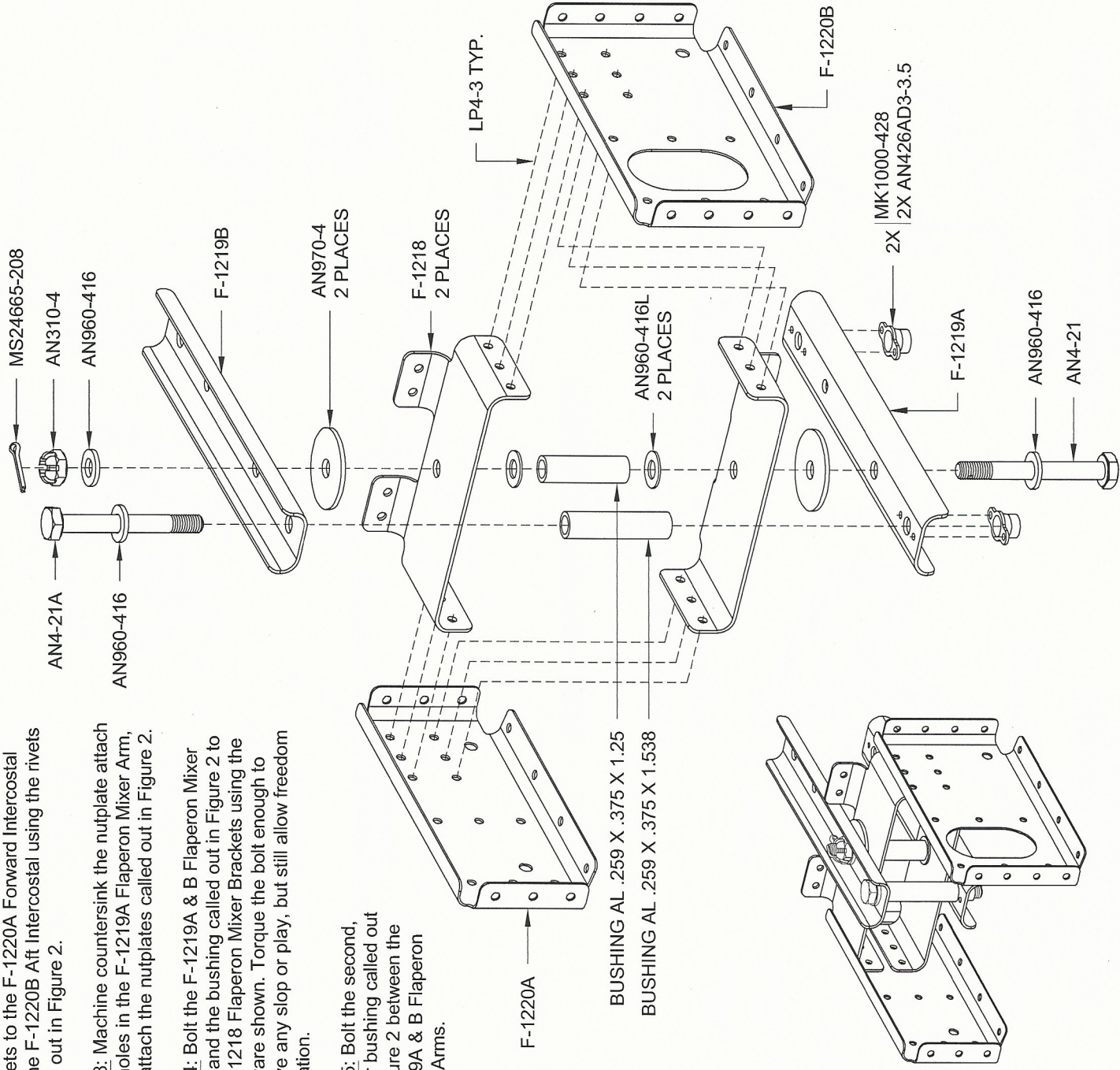

**FIGURE 2: FLAPERON MIXER ARM ASSEMBLY**

Step 6: Separate the four F-1017C Seat Belt Attach Lugs, shown in Figure 3, and the two F-1216 Seat Belt Attach Lug Supports, shown in Figure 4, by removing the hatched areas shown.

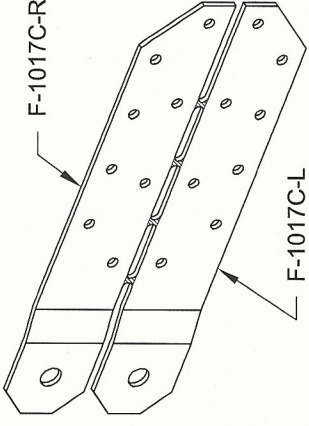
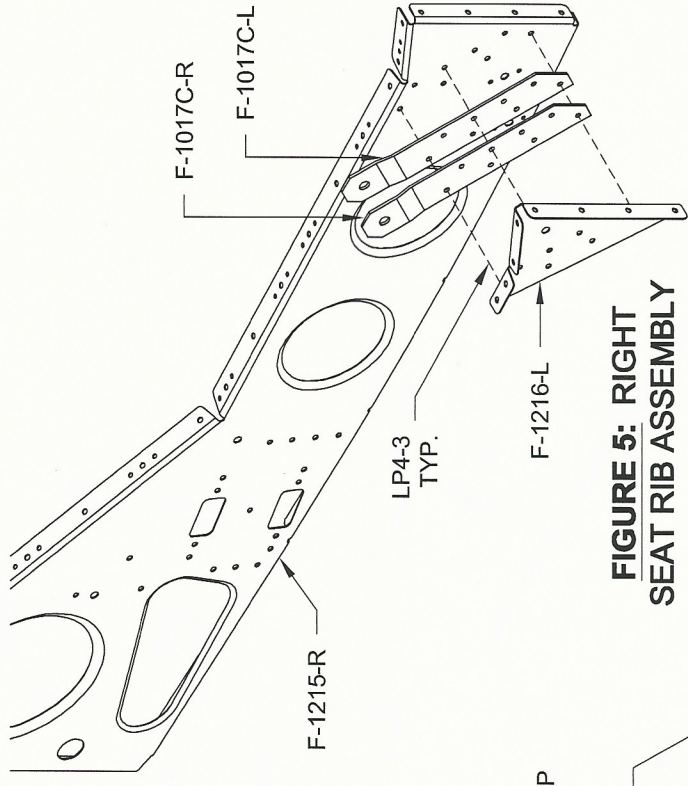

**FIGURE 3: SEPARATE F-1017C SEAT BELT ATTACH LUG**

Step 7: Remove the vertical strip of material from the lightening hole of each F-1215-L & -R Seat Rib as indicated in Figure 6.

Step 8: Using F-1215-L & -R Seat Ribs, F-1017C-L & -R Seat Belt Attach Lugs, and F-1216-L & -R Seat Belt Attach Lug Supports, cleco together four Seat Rib Assemblies; two right as shown in Figure 5, and two left as shown in Figure 6.

Step 9: Final-Drill #30 the eight 1/8 dia. holes common to all the parts shown in Figures 5 and 6, then rivet them together using the rivets called out.



**FIGURE 5: RIGHT SEAT RIB ASSEMBLY**

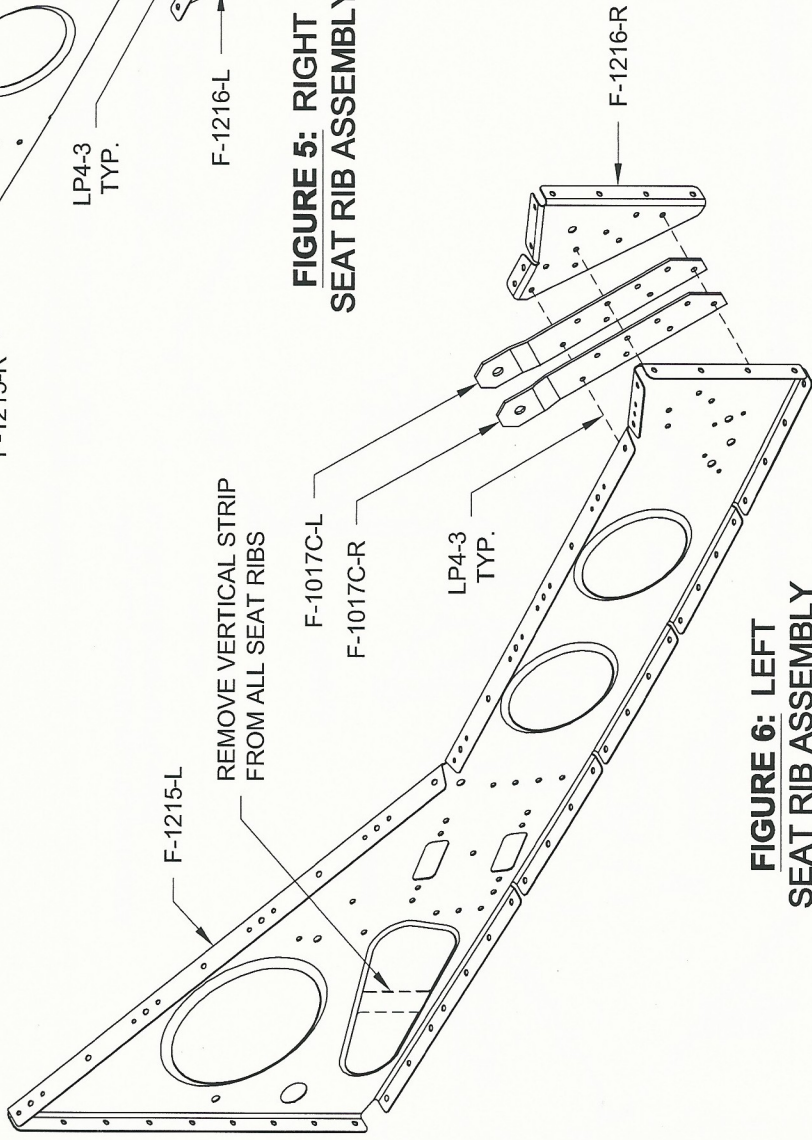

**FIGURE 6: LEFT SEAT RIB ASSEMBLY**