



NOTE: Before proceeding with this section return to page 12-04 Step 4 and complete the remainder of Section 12 leaving the empennage attached.

Step 1: Bolt the VA-107 Brake Reservoir to the F-1201A Firewall Upper using the hardware called out in Figure 1.

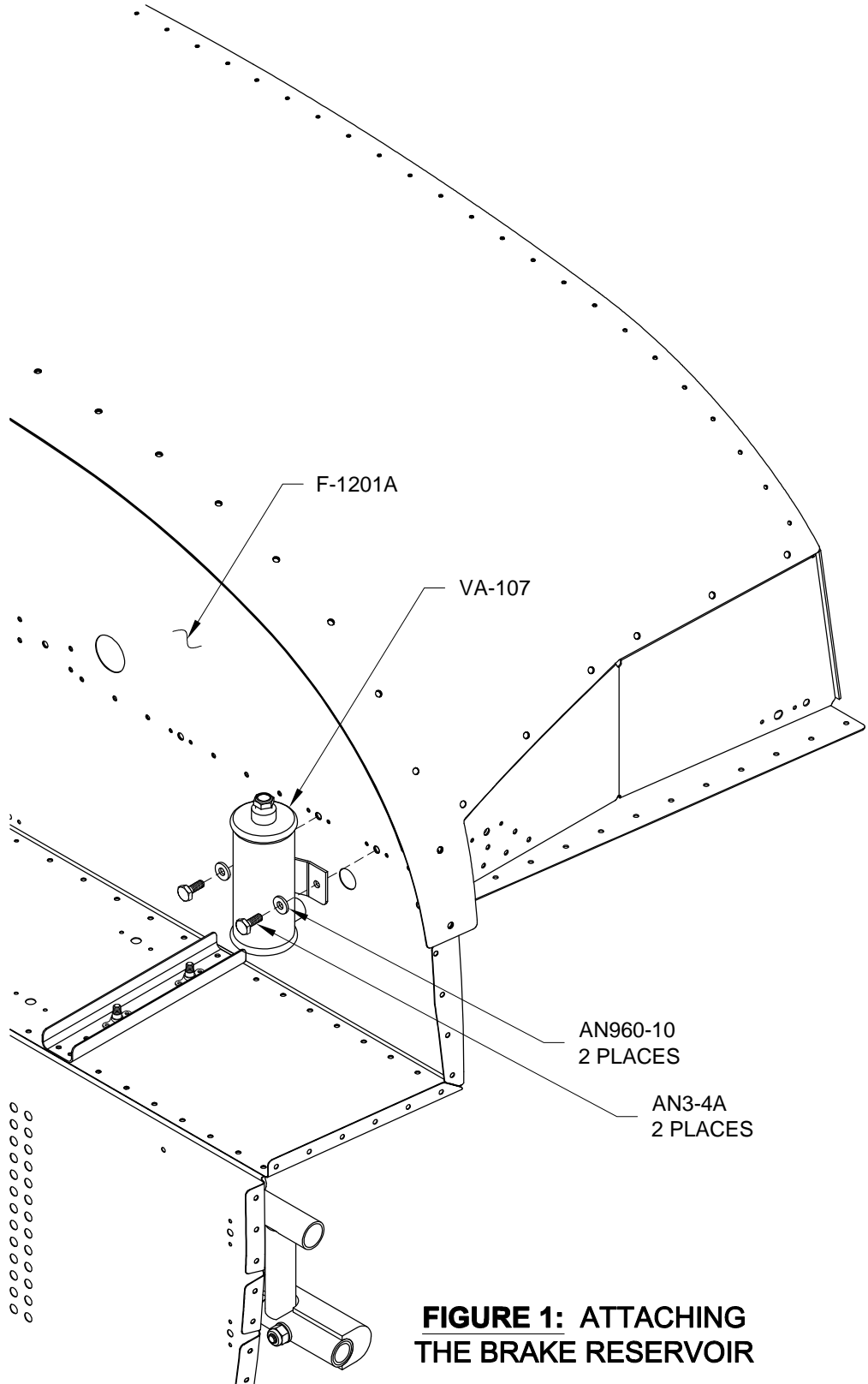

FIGURE 1: ATTACHING THE BRAKE RESERVOIR

Step 2: Secure the F-1289A-L & -R Reservoir Brake lines to the VA-107 Brake Reservoir as shown in Figure 2. Loosen the Nylon Nuts, insert the reservoir brake lines, push hard until they bottom-out in the Male Nylon Tee, then tighten the Nylon Nuts. Use thread sealant for the connection between the Male Nylon Tee and the brake reservoir.

Step 3: Secure the F-1289A-L & -R Reservoir Brake Lines and F-1289B-L & -R Cross-Over Brake lines (the four brake lines attached to the right side master cylinders) to the bottom of the F-1202B Panel Base using the hardware called out in Figure 2.

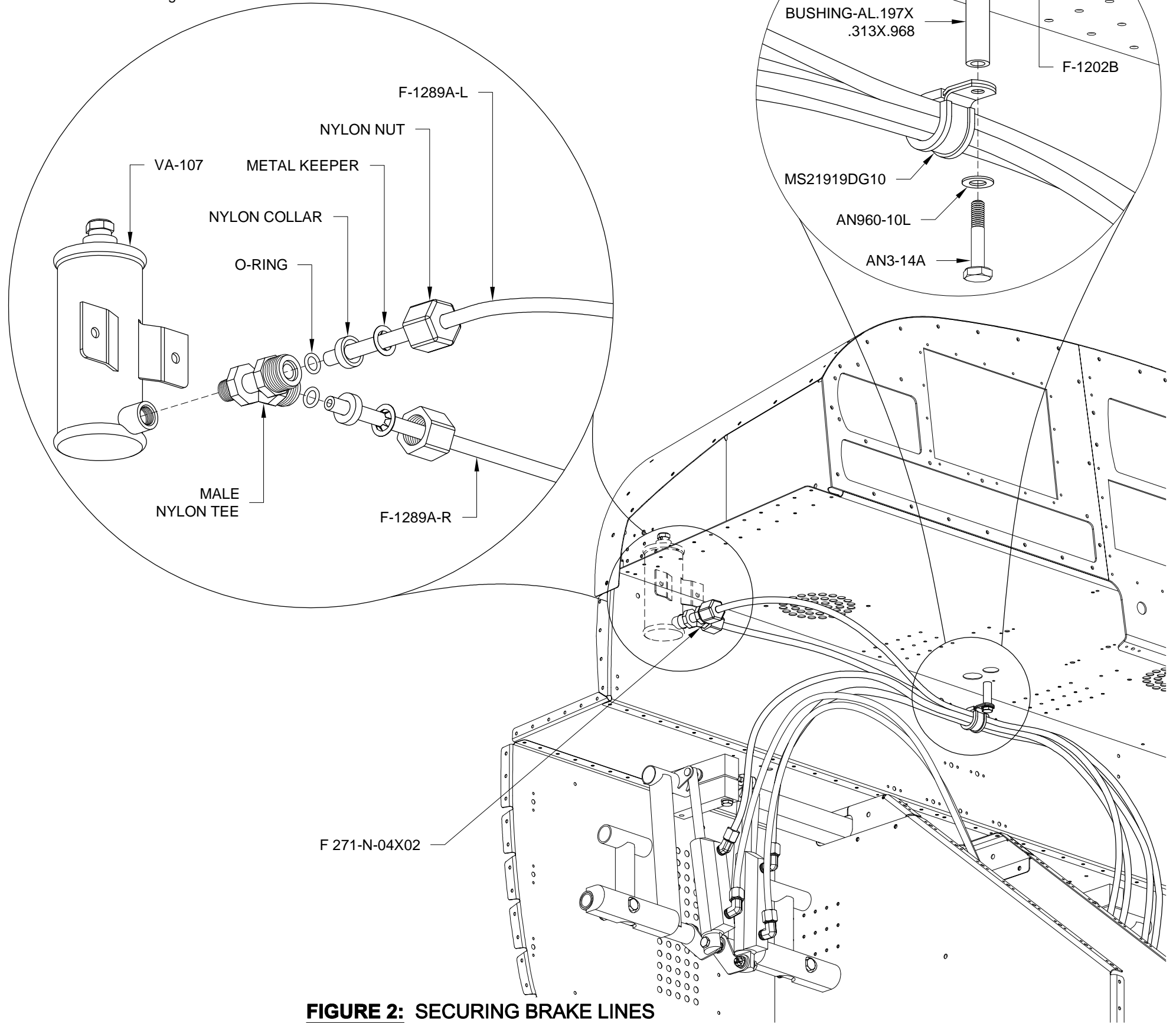

FIGURE 2: SECURING BRAKE LINES