

Step 1: Separate the F-1260B Flap Handle Fork and the F-1260C Flap Handle Spacer into individual parts by removing the shaded areas shown in Figure 1.

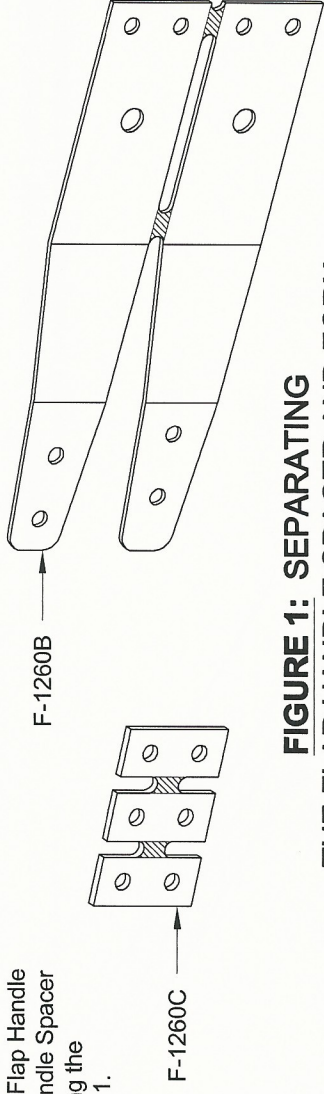

FIGURE 1: SEPARATING THE FLAP HANDLE SPACER AND FORK

Step 2: Make the Fork Assembly using the F-1260B Flap Handle Forks, the F-1260C Flap Handle Spacers, and the hardware called out in Figure 2.

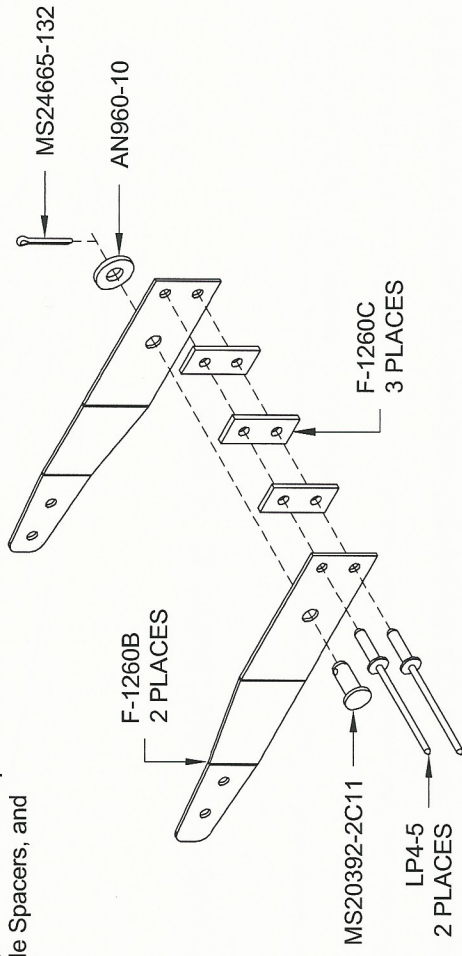

FIGURE 2: FORK ASSEMBLY

Step 3: Cut the F-1260A Flap Handle Tube to length according to the dimension provided in Figure 3.

Step 4: Carefully align the Fork Assembly with the F-1260A Flap Handle Tube, clamp the parts together, then match-drill #30 the two holes in both sides of the Fork Assembly into the flap handle tube.

Step 5: Attach the Fork Assembly to the F-1260A Flap Handle Tube using the rivets called out in Figure 3.

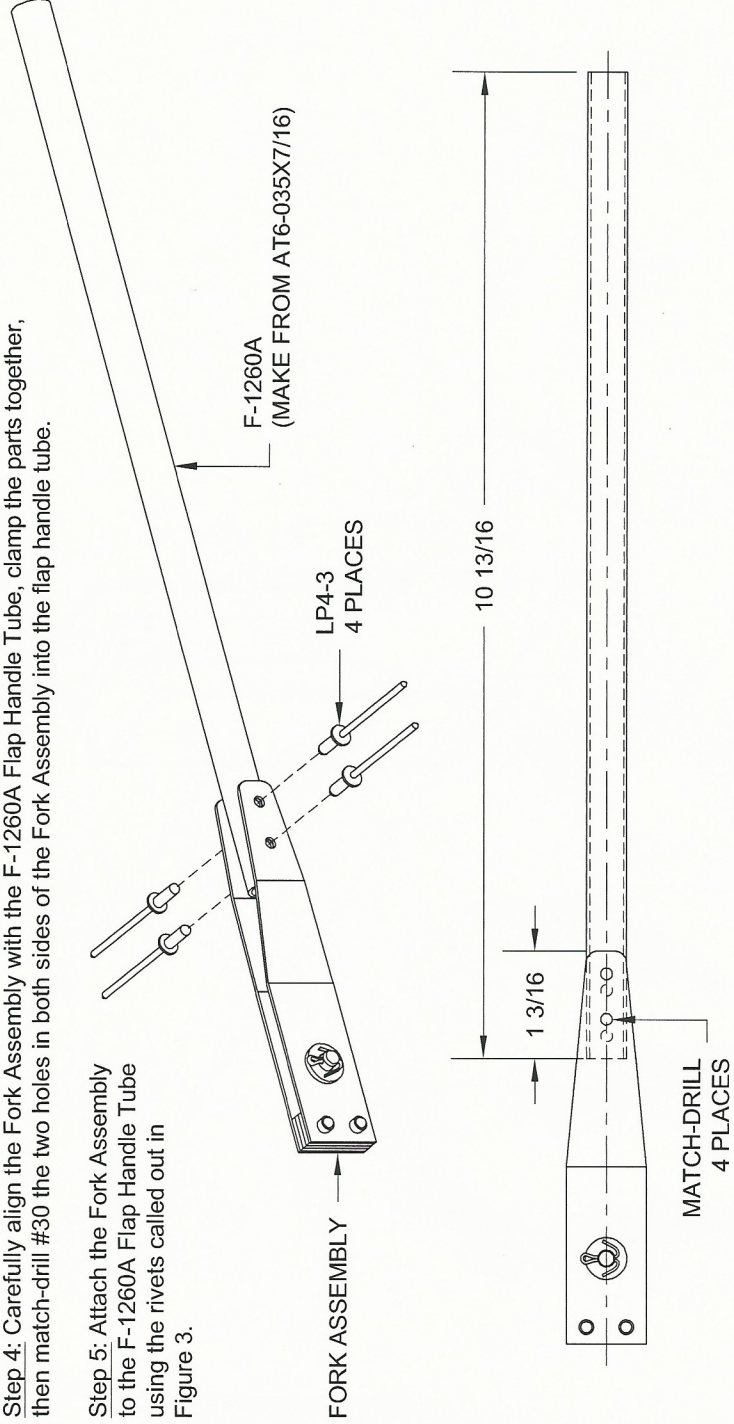

FIGURE 3: ATTACHING THE FORK ASSEMBLY

Step 6: Separate the F-1266C Flap Detent Bracket Angle and the F-1266AD Flap Detent Bracket / Stop into individual parts by removing the shaded areas shown in Figures 4 and 5.

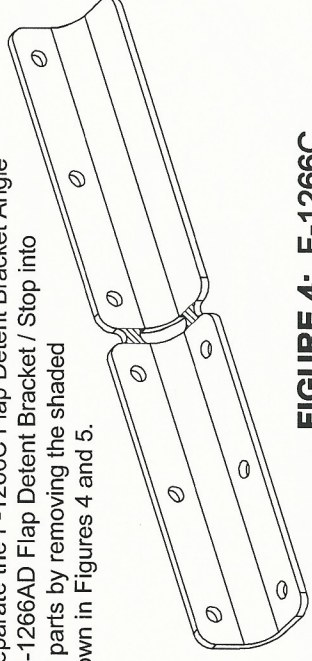

FIGURE 4: F-1266C FLAP DETENT BRACKET ANGLE

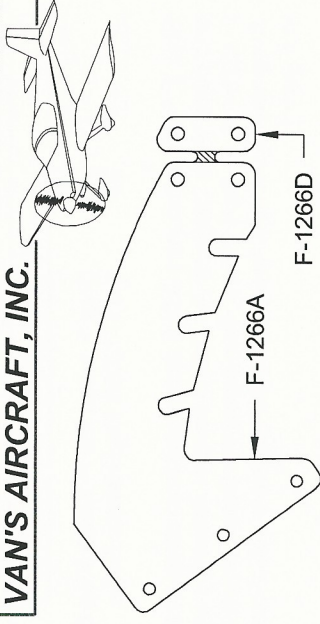

FIGURE 5: F-1266AD FLAP DETENT BRACKET/ STOP

Step 7: Attach the F-1266C Flap Detent Bracket Angles to the F-1266A Flap Detent Bracket using the rivets called out in Figure 6.

Step 8: Cleco the F-1266C Flap Detent Angle that has the holes in its horizontal flange to the F-1266B Flap Detent Bracket Plate as shown in Figure 6.

Step 9: Match-Drill #30 the holes of the F-1266B Flap Detent Bracket Plate into the F-1266C Flap Detent Angle that has no holes in its horizontal flange.

Step 10: Machine countersink the bottom of the F-1266B Flap Detent Bracket Plate for the rivets shown in Figure 6.

Step 11: Attach the F-1266C Flap Detent Bracket Angles to the F-1266B Flap Detent Bracket Plate using the rivets called out in Figure 6.

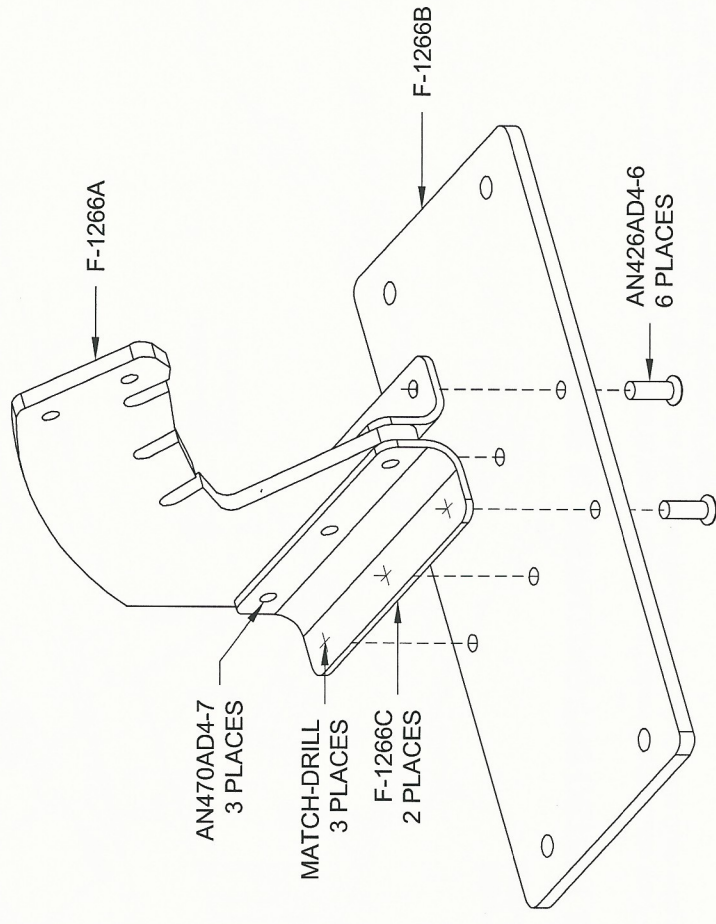

FIGURE 6: DETENT BRACKET ASSEMBLY

Step 12: Press the VA-110 Flap Knob onto the end of the Fork Assembly, then slide the VA-114 Compression Spring and the Fork Assembly into the WD-1213 Flap Handle as shown in Figure 7.

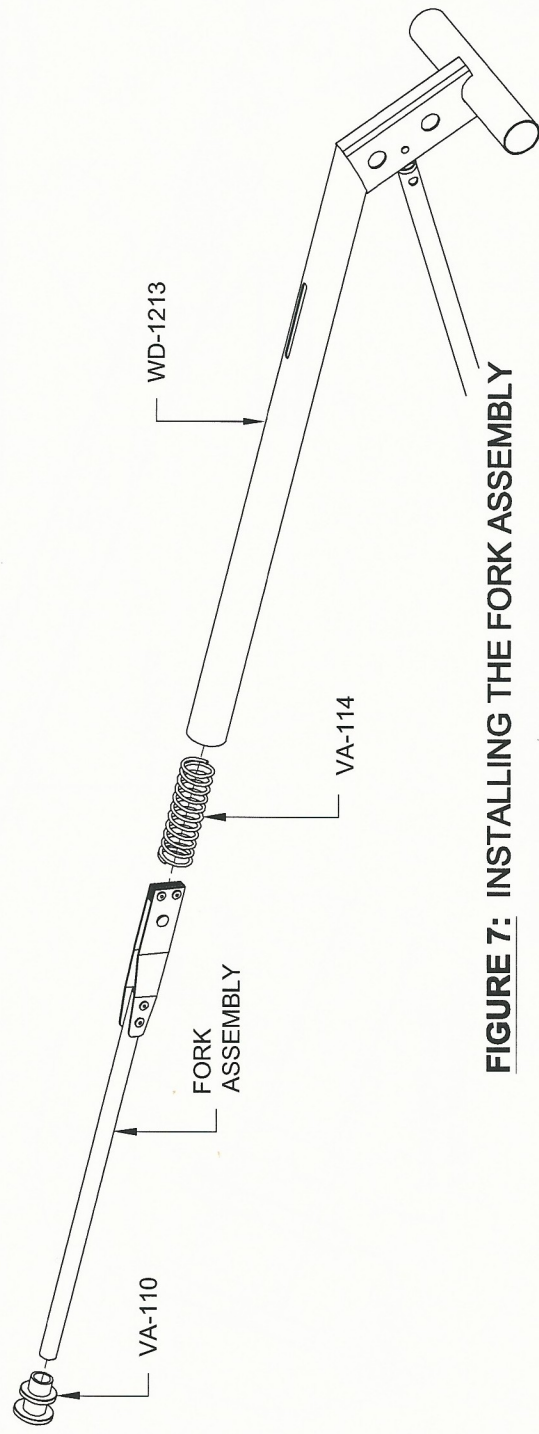

FIGURE 7: INSTALLING THE FORK ASSEMBLY