

Step 1: From the 12 inch length of MS21266-1N Nylon Grommet supplied, cut two 3-3/16 lengths and install them around the edges of the holes in the F-1273-L & -R Baggage Corner Skins as shown in Figure 1.

Step 2: Slide the WD-1214-L & -R Flaperon Torque Tubes through the holes in the F-1273-L & -R Baggage Corner Skins and between the brackets of the WD-1215L & -R Flaperon Torque Arms as shown in Figure 1.

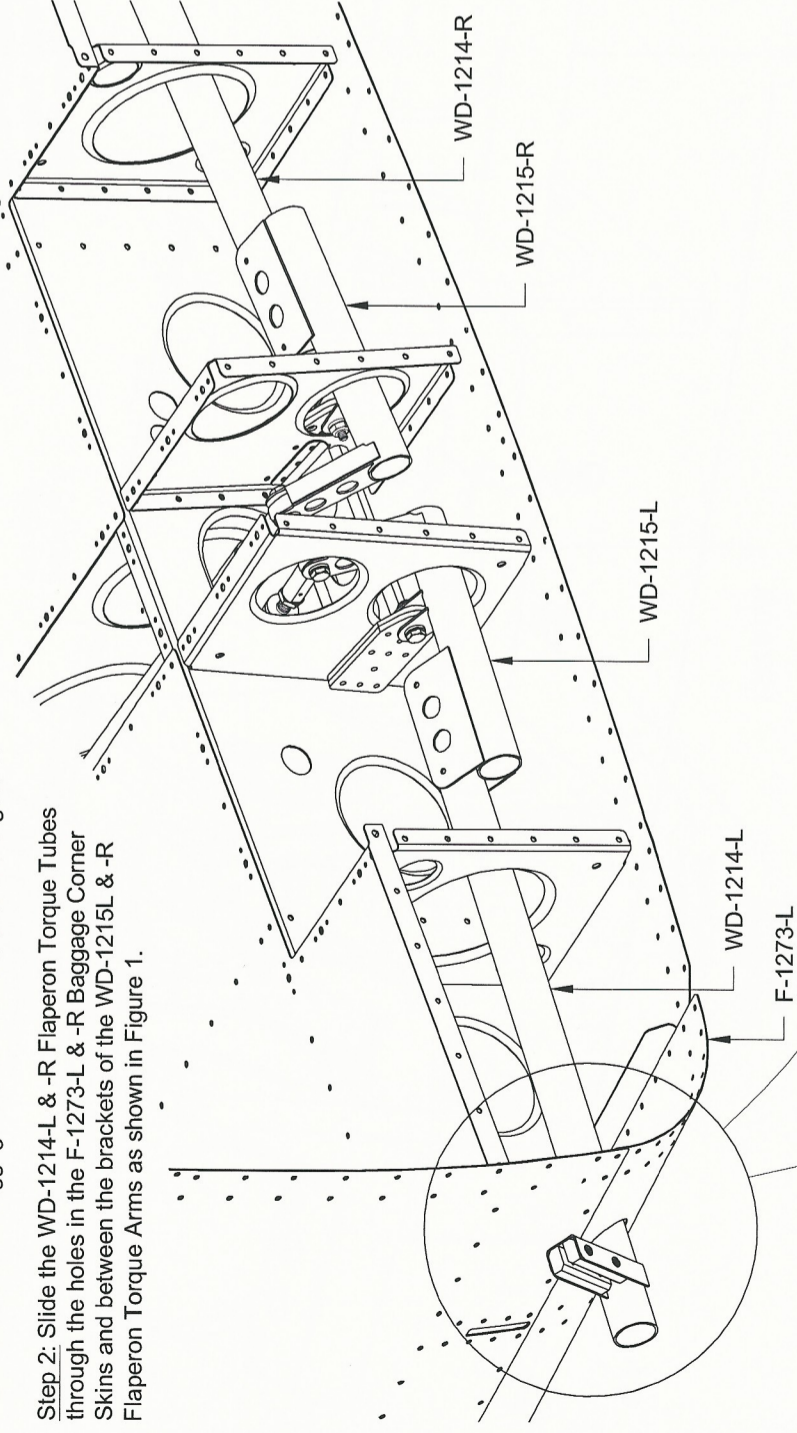

FIGURE 1: INSTALLING THE FLAPERON TORQUE TUBE

Step 3: Place the WD-1213 Flaperon Handle in the lowest (flaps up) detent in the F-1266A Flaperon Detent Bracket, then use the bolt shown in Figure 2 to temporarily lock the flaperon control system in the neutral position. Pass the bolt through the holes in both F-1219 Flaperon Mixer Arms and F-1263A & B Flaperon Mixer Bellcranks.

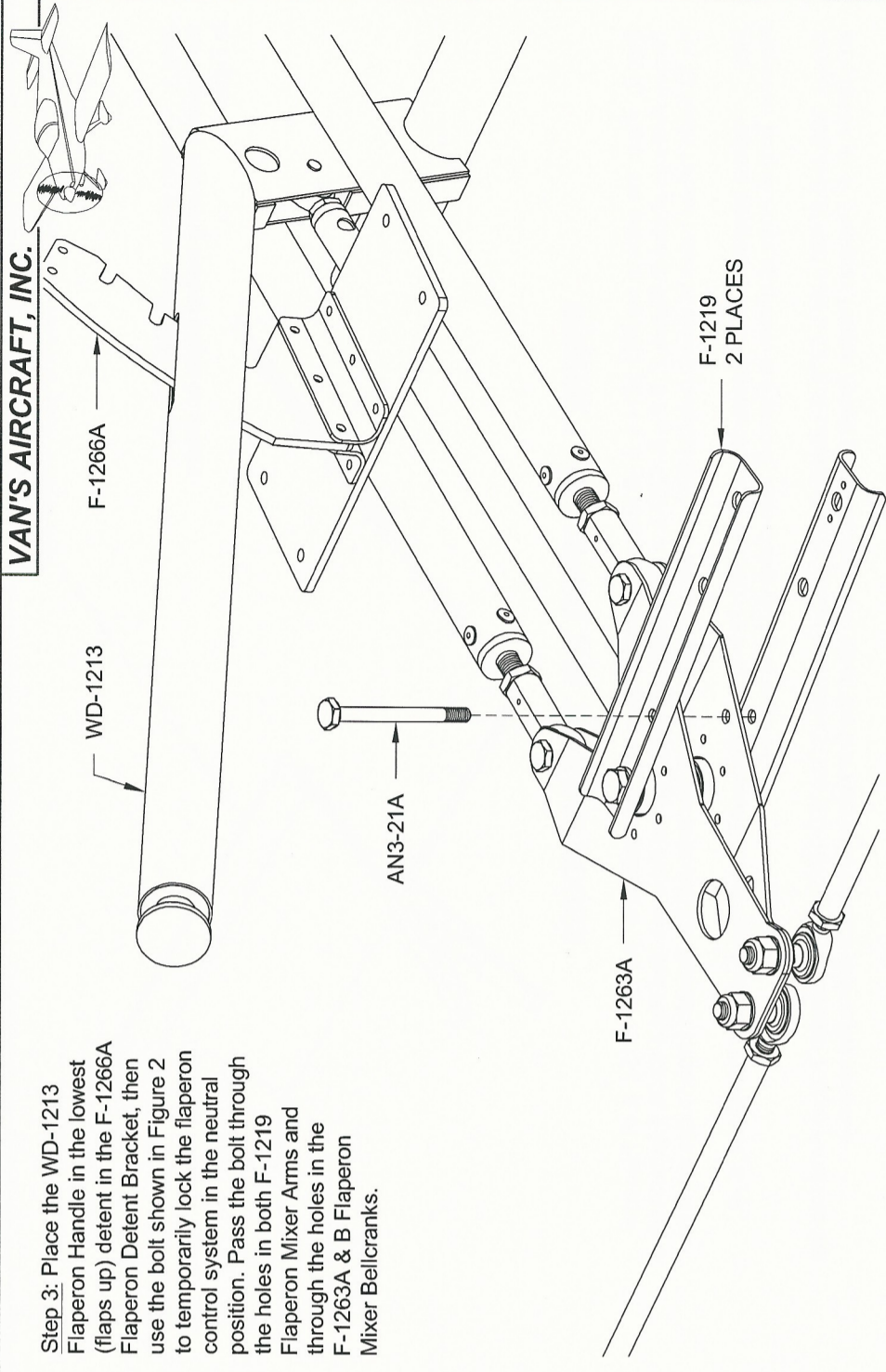

FIGURE 2: LOCKING THE FLAPERON CONTROL SYSTEM

Step 4: Install the wings. During installation, slide the A-1211 Pivot Guides into the WD-1214-L & -R Flaperon Torque Tubes and the A-1207-L & -R Actuation Brackets between the F-1261 Spacers as shown in Figure 4.

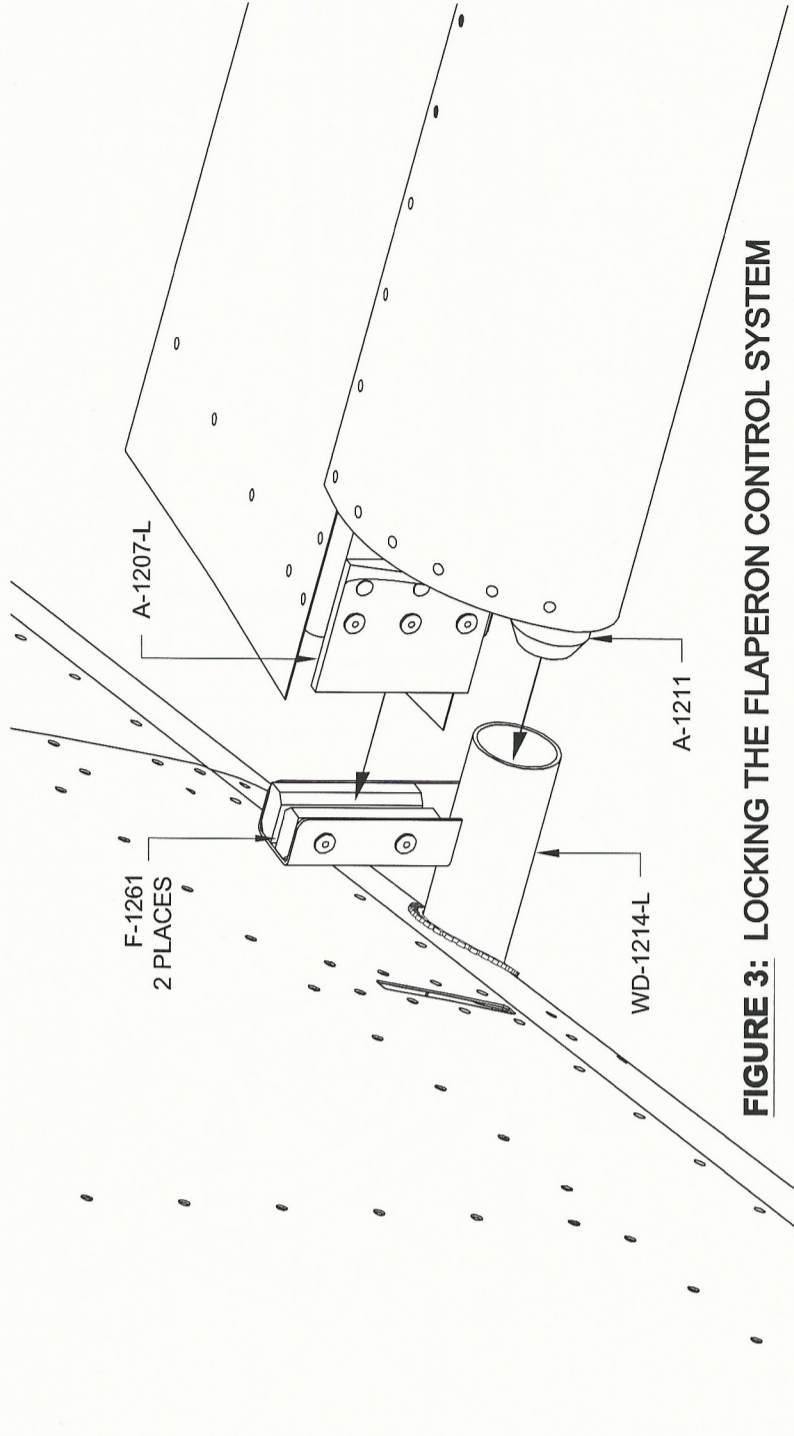

FIGURE 3: LOCKING THE FLAPERON CONTROL SYSTEM